

Installation & Operation Manual

WBL-2320 Series

Ligature Resistant Behavioral Healthcare Lavatory Infrared/Pneumatic

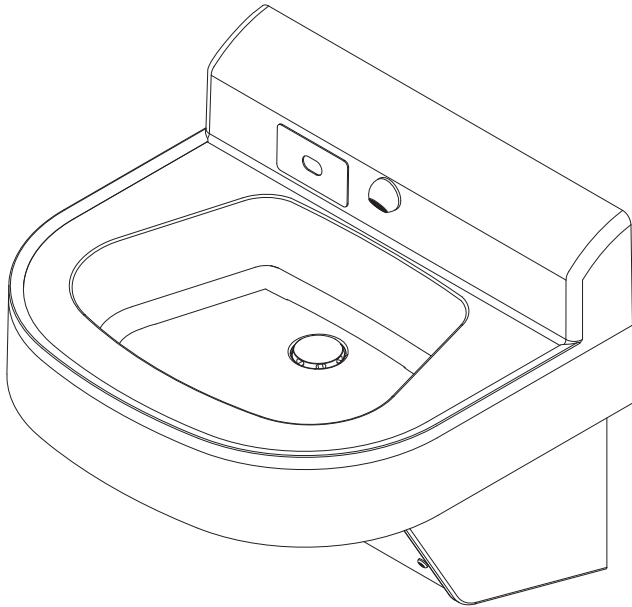

WBL-2320 Infrared

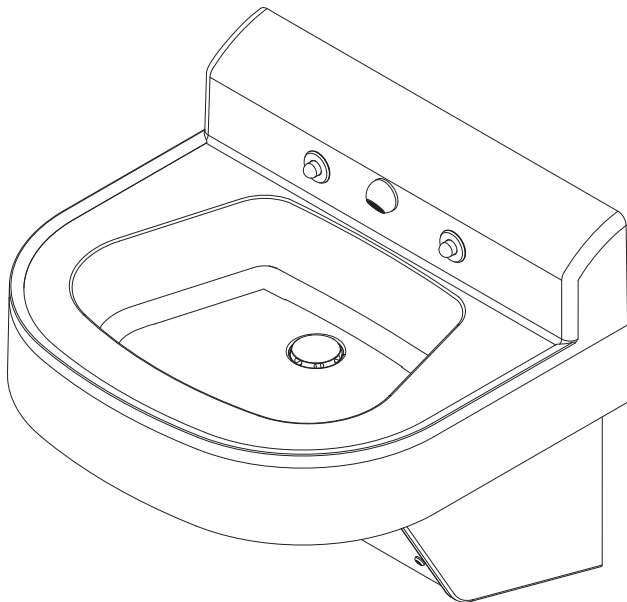

WBL-2320 Pneumatic

Table of Contents

Pre-Installation Information.....	3
Physical Dimensions	4
Mounting Dimensions	5
Checking Contents	6
Required Installation Supplies	7
Parts List	8
Exploded-view Drawing.....	9
Hardware Identification	10
Carrier Recommendation	11
Installation Instructions	
Step 1: Pedestal Mounting.....	12
Step 2: Drain Assembly #380280	13
Step 3A: Backsplash Connections for Infrared Actuators	14
Step 3B: Backsplash Connections for Pneumatic Actuators.....	15
Step 4: Basin and Pedestal Assembly	16
Step 5: Final Assembly	17
JACO Fitting Instructions.....	18
Adjustable Mixing Valve Installation	19
Infrared Lavatory Sensor Installation.....	20
Pneumatic Valve Operation Details	21
Valve Configurations.....	22
Care and Maintenance	23
Troubleshooting	
Infrared Sensors	24
Electronic Valves	25
Pneumatic Valves	26
Drawings.....	
General Dimensions and Rough-in Detail	27
Warranty.....	28



Willoughby Industries, Inc.

5105 West 78th Street
Indianapolis, IN 46268

Toll Free: (800) 428-4065

Local: (317) 875-0830

Fax: (317) 875-0837

www.willoughby-ind.com

WILLOUGHBY

Rev. 4/2015

MADE IN THE U.S.A.



(Page left intentionally blank)

Pre-Installation Information

Installation notice!

Check Rough-In location **PRIOR** to installation

Flush lines thoroughly **PRIOR** to hook-up

When installing the **Willoughby Industries' WBL-2320 Series** lavatory deck systems:

Before step 1 of the installation instructions, ensure that rough-ins are in the correct location.

The valve assembly, including the spray head, **MUST NOT BE** connected until *after* all lines have been flushed to remove the small particles of debris that are inherent with new construction projects and all chemicals that are used in flushing are purged from the system.

Chemicals used in flushing plumbing systems can attack the internal components of the valve and spray head and severely damage them, so any flushing of the system must be followed by a full flushing with pure water to clear any harsh chemicals remaining in the system. Debris in the system if allowed to enter the valve assembly and spray head can cause poor performance or outright failure.

Again **DO NOT** attempt to connect the valve assembly and spray head until *after* all flushing is complete and pure water is the only media that will be passing through the system. Damage to the valve assembly or spray head caused by harsh chemicals or debris will not be covered by the manufacturer's warranty.

Installation notice!

Check Rough-In location **PRIOR** to installation

Flush lines thoroughly **PRIOR** to hook-up

Physical Dimensions- WBL-2320

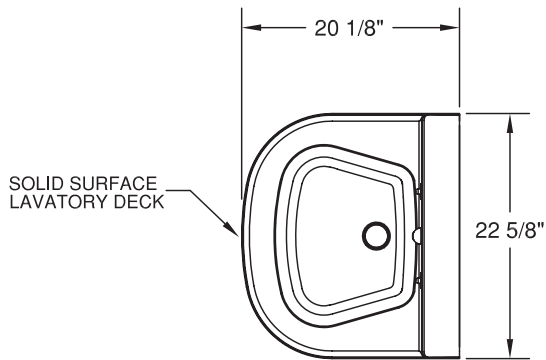

TOP VIEW

 IN COMPLIANCE WITH
 T.A.S. AND A.D.A. 2010

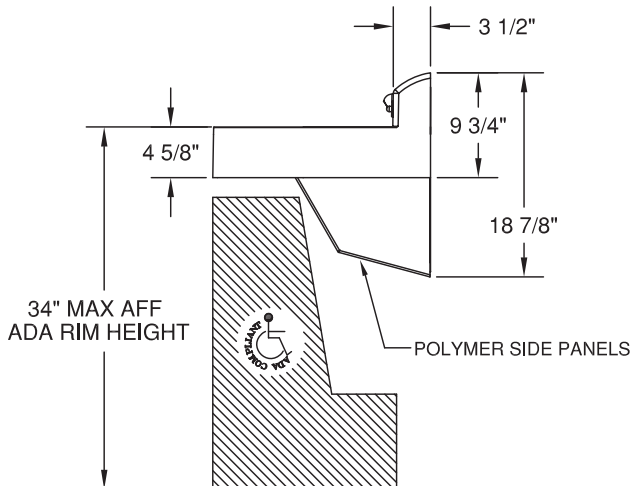

SIDE VIEW

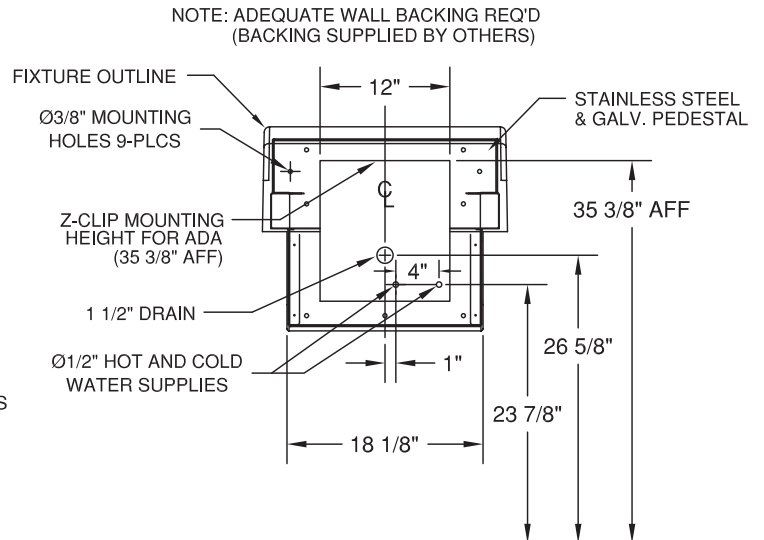

BACK VIEW

FINISHED FLOOR

Mounting Dimensions- WBL-2320

Drill Template (Ref. S300897)

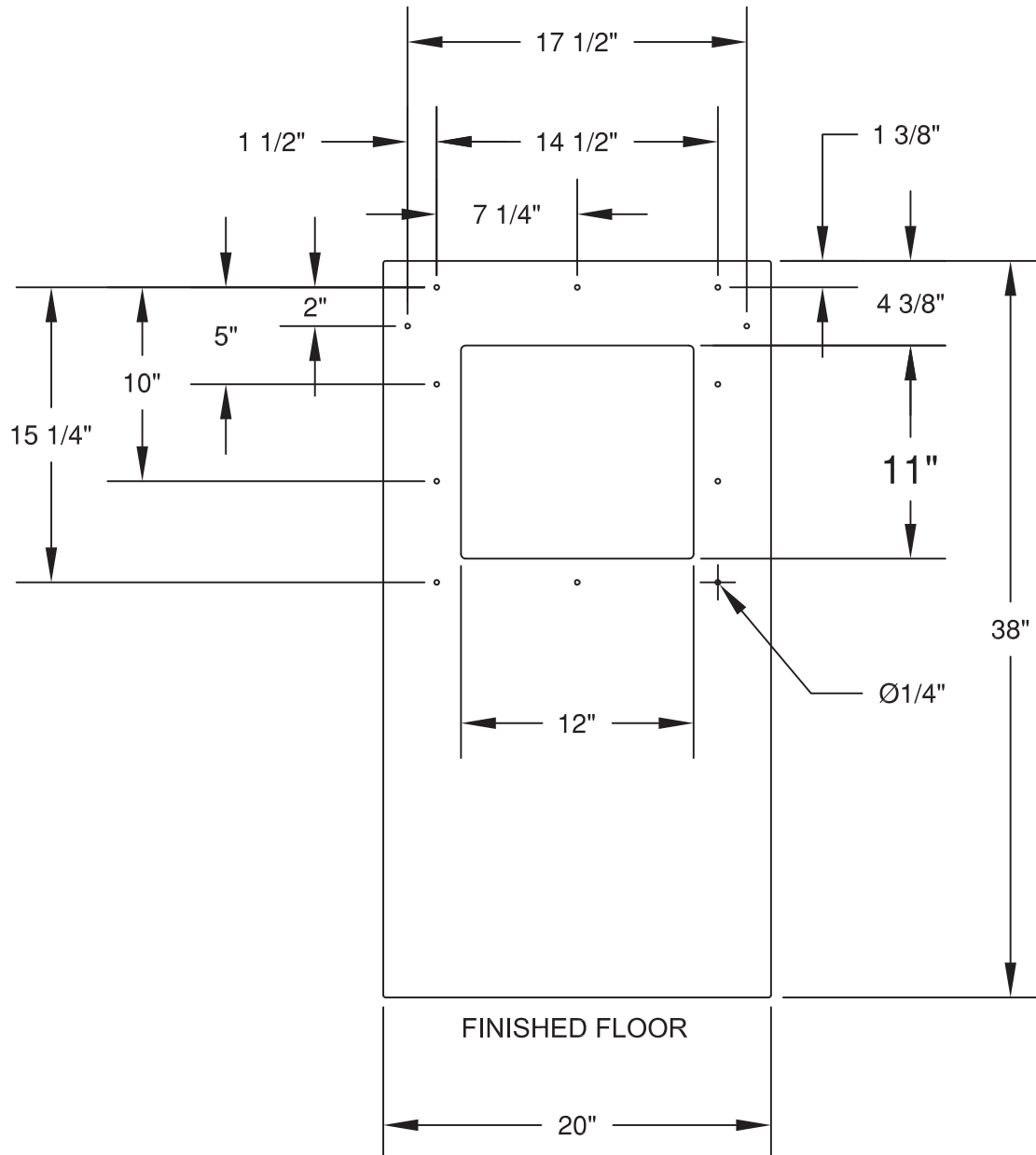

Check Contents

- Separate all parts from packaging and make sure all parts are accounted for before discarding any packaging material. If any parts are missing, do not attempt to install WBL-2320 Behavioral Health Lavatory until you obtain the missing parts.

NOTE: Before beginning installation, all supply, drain and waste piping for the WBL-2320 must be completed according to specified rough-ins. If you have not received rough-in details, please contact Willoughby Industries, Inc. (800) 428-4065

- IMPORTANT:** These installation instructions cover all of the Willoughby Industries Inc. WBL-2320 Behavioral Health Lavatory Series. Simply omit the steps which do not apply to the model you are installing.
- IMPORTANT:** Flush all the water supply lines before making connections.

Required Installation Supplies

- Proper mounting hardware
- Hardware for waste outlet connections
- Gasket for waste outlet connection
- Shims (for installation if necessary)
- Supply piping
- Silicone caulk
- Plumbers putty

WARNING: Willoughby Industries does not assume any responsibility for personal injury or damage to equipment due to an improperly installed WBL-2320 Behavioral Health Lavatory.

Parts List

ITEM	DESCRIPTION	PUSHBUTTONS	INFRARED
1	PUSHBUTTON ASSEMBLY	600318	N/A
2	DOUBLE "D" BACKPLATE	S300735	S300754
3	SPRAY HEAD	800002	800002
4	LAVATORY BASIN	WBL2320-XX*	WBL-2320-XX*
5	DRAIN ASSEMBLY, WBL-2320	380280	380280
6	PEDESTAL ASSEMBLY, WBL-2320	S300734	S300734
7	1/2-20 x 1/2" SECURITY SCREW	4500NSS	4500NSS
8	TINNERMAN CLIP 1/4-20	800113	800113
9	1/4-20 x 3/4" SECURITY SCREW	4502SSN	4502SSN
10	TRAP COVER	S300732	S300732
11	6" "Z" CLIP	800005	800005
12	SIDE PANEL SET	SB902320	SB902320
13	1/4-20 PHILLIPS TRUSS HEAD SCREW	800144	800144
14	1/4-20 x 7/8" FLAT WASHER	600650	600650

*XX REPRESENTS THE LAVATORY COLOR

WHITE GRANITE=WG
SAND STONE=SS
GRAY GRANITE=GG
BLACK GRANITE=BG
SEA GREEN=SG
NOCTURNAL BLUE=NB
RED CORAL=RC
GLACIER WHITE=GW
BONE=B

Exploded-view Drawing

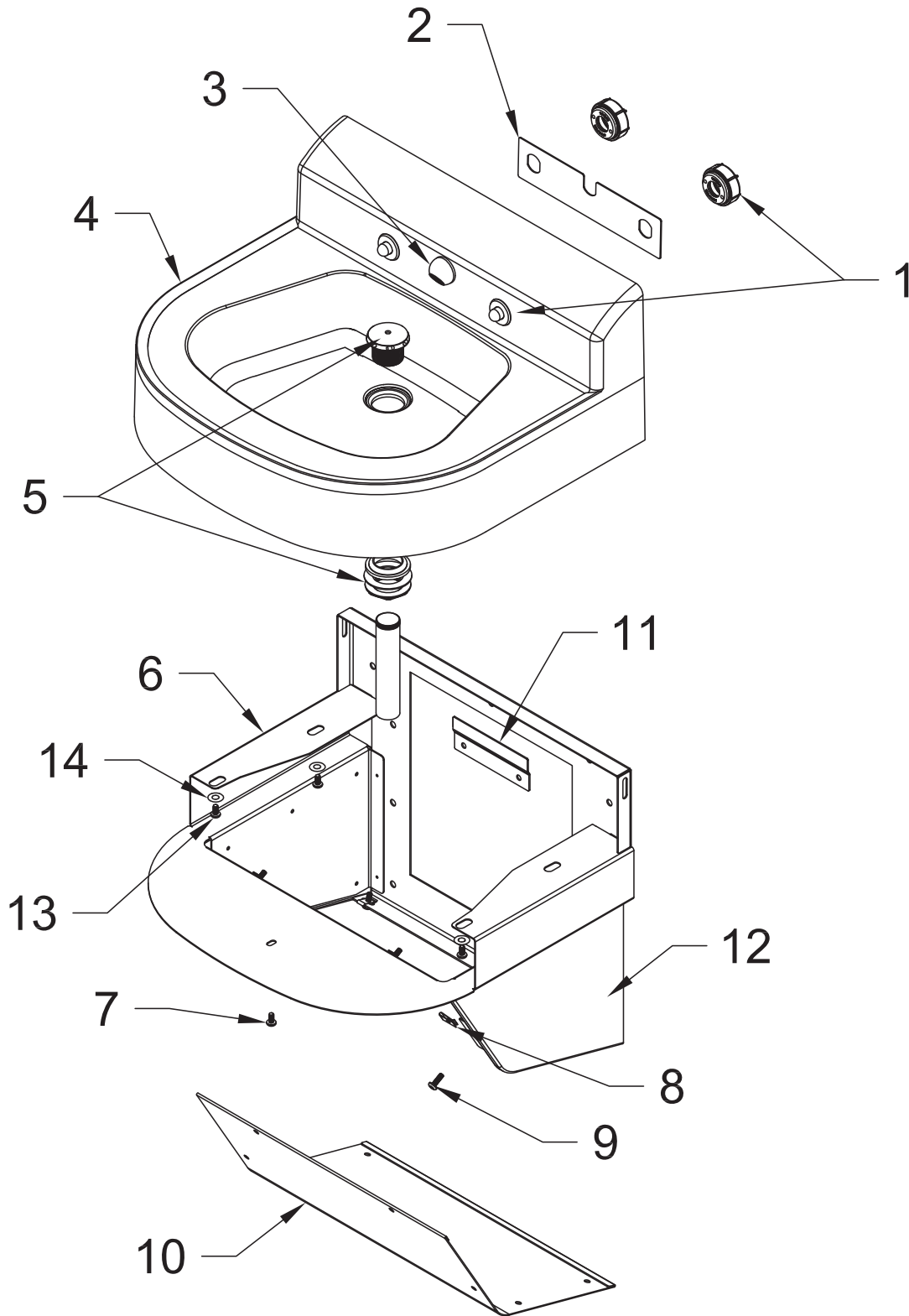

Hardware Identification

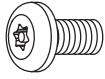

1/4-20 x 1/2"
SECURITY SCREW
4500NSS

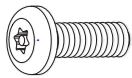

1/4-20 x 3/4"
SECURITY SCREW
4502SSN

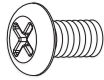

1/4-20 x 1/2"
PHILLIPS
TRUSS HEAD SCREW
800144

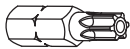

TT27
PINNED TORX BIT

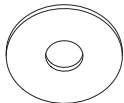

1/4-20 x 7/8"
FLAT WASHER
600650

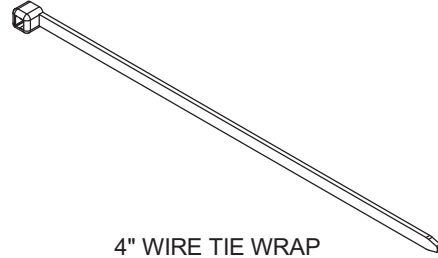

4" WIRE TIE WRAP
701173

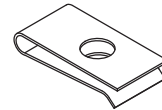

1/4-20
TINNERMAN NUT
800113

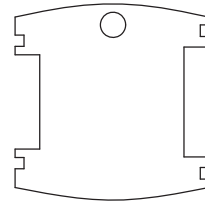

SECURITY SPANNER TOOL
800116

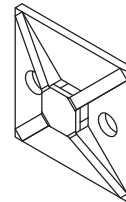

4 WAY WIRE TIE BASE
701206

Carrier Recommendation

Note: Carrier Provided By Others.

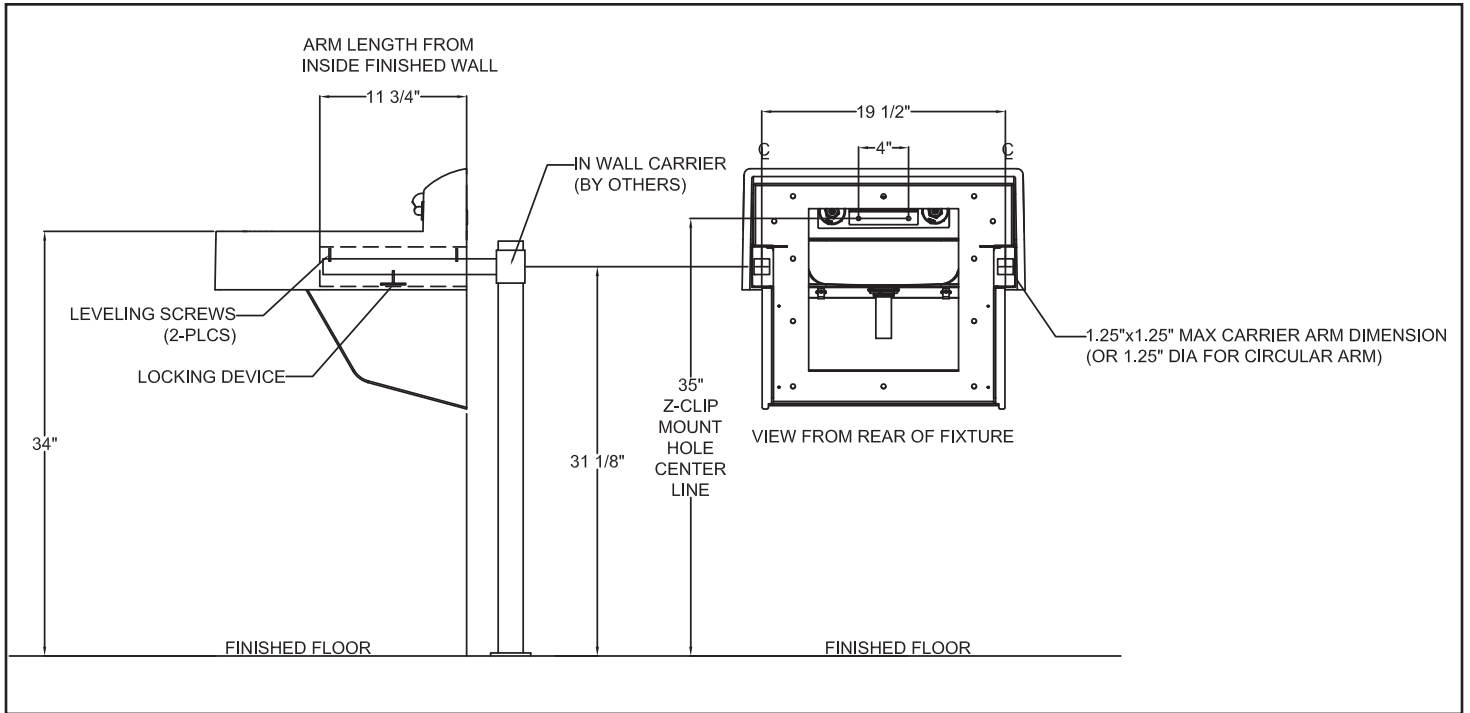

Installation Instructions

Step 1: Pedestal Mounting

Parts supplied:

- Pedestal (pre-assembled)
- Mounting Bracket

Note: Hardware for wall anchoring by others

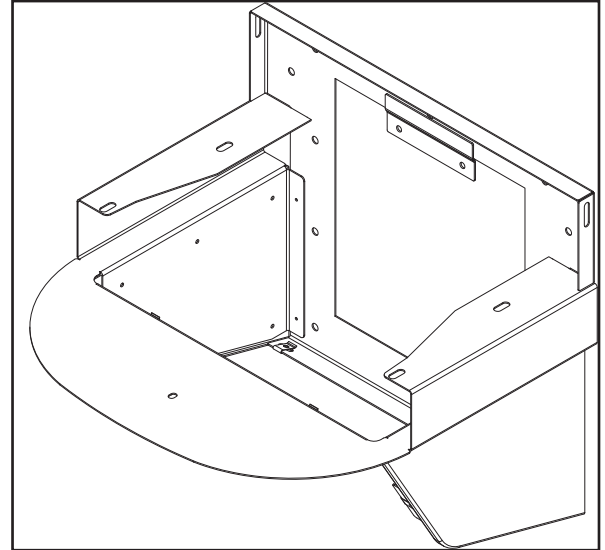

- 1.) Remove plastic protective coating from all stainless parts before installation.
- 2.) Measure and mark the vertical centerline of the lavatory on the wall. Mark a level line at 1 inch above desired rim height: ie...place a line at 35" for a 34" rim height.
- 3.) Place mounting "Z" clip bracket (S300358) against the wall and align the middle mounting holes with vertical centerline marked on the wall.
- 4.) Secure the bracket to the wall using wall anchors that are adequate for the type of wall; drywall, concrete, metal studs, wood studs, etc. (supplied by others).
- 5.) Place pedestal onto the mounting bracket with upper channel support resting on the bracket.

Note: Pedestal must be level for fixture to drain properly

- 6.) Secure pedestal to the wall using **all** thru holes for secure mounting (adequate wall anchoring hardware and support by others).

Installation Instructions (cont.)

Step 2: Drain Assembly #380280

Parts/Materials supplied:

- Solid Surface basin
- Drain assembly

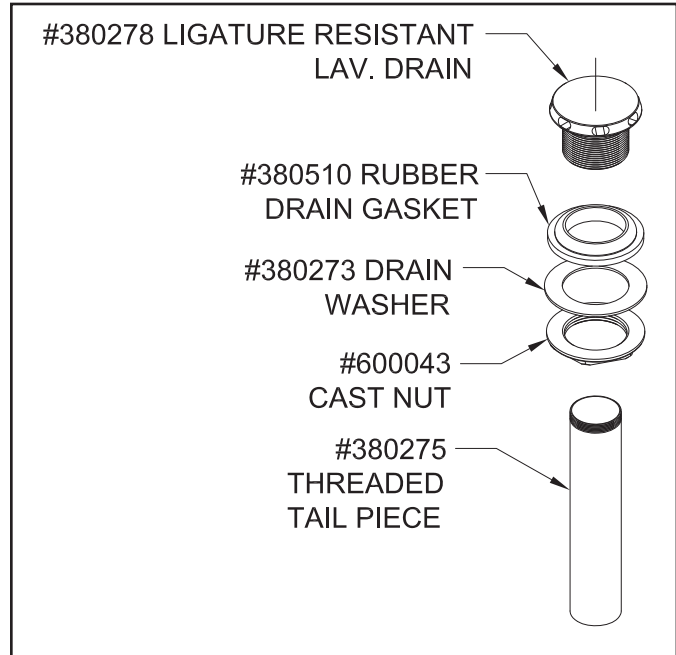

- 1.) Insert drain spud into wash basin using plumbers putty (supplied by others).
- 2.) From beneath basin, thread the washers & locknut onto the drain spud and secure locknut against wash basin.
- 2.) The wash basin is ready for plumbing and/or electrical installation*.

***If you have pneumatic pushbuttons, go to Step 4A.
If you have infrared sensors, go to Step 4B.**

Installation Instructions (cont.)

Step 3A: Backsplash Connections for Infrared Actuators

Caution: Do not leave bowl on the pedestal unsupported, as it may fall and cause damage or personal injury.

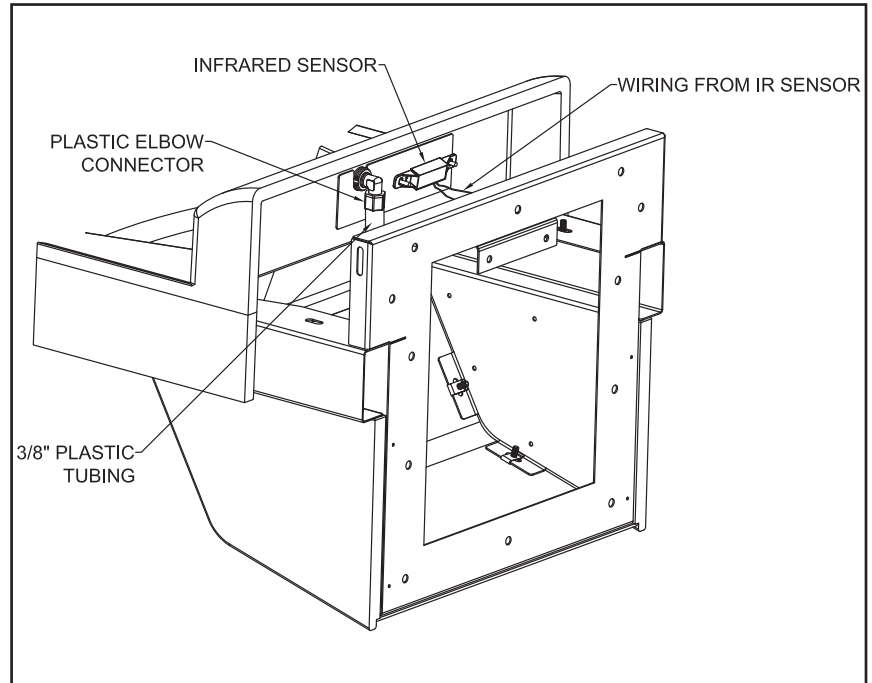

- 1.) The valves are installed at the factory.
- 2.) Locate the loose red wire coming from the valve or power supply.
- 3.) Feed wires to each of the actuators in the housing assembly and connect to the terminals.

Note: Use wire tie mounts and wire ties to route and secure wiring. Wires are long enough to accommodate various routing paths. Longer wires may need to be bundled with wire ties so that they do not come in contact with sharp corners, route through rubber grommets.

- 4.) Locate the 3/8" x 3' clear tube water line. Loosen the plastic nut and firmly push the tubing into the connector located on the spray head and tighten nut securely (see JACO Fitting Instructions on Page 18).

Installation Instructions (cont.)

Step 3B: Backsplash Connections for Pneumatic Actuators

Caution: Do not leave bowl on the pedestal unsupported, as it may fall and cause damage or personal injury.

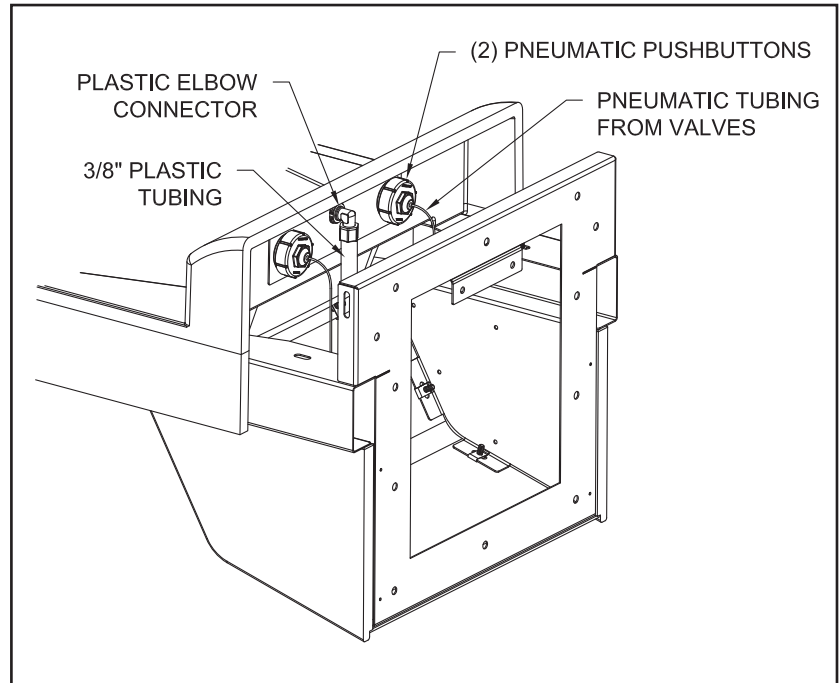

- 1.) The valves are installed at the factory.
- 2.) Locate the small pneumatic tubing. Feed each one into the actuator housing assembly and plug the tubing onto the hose barb on the back of the pushbutton.

Note: Use wire tie mounts and wire ties to route and secure tubing. Tubing is long enough to accommodate various routing paths. Longer tubes may need to be bundled with wire ties so that they do not come in contact with corners, route through rubber grommets.

- 3.) Locate the 3/8" x 3' clear tube water line. Loosen the plastic nut and firmly push the tubing into the connector located on the spray head and tighten nut securely (see Jaco Fitting Instructions on Page 18).

Installation Instructions (cont.)

Step 4: Basin and Pedestal Assembly

Caution: Do not leave bowl on the pedestal unsupported, as it may fall and cause damage or personal injury.

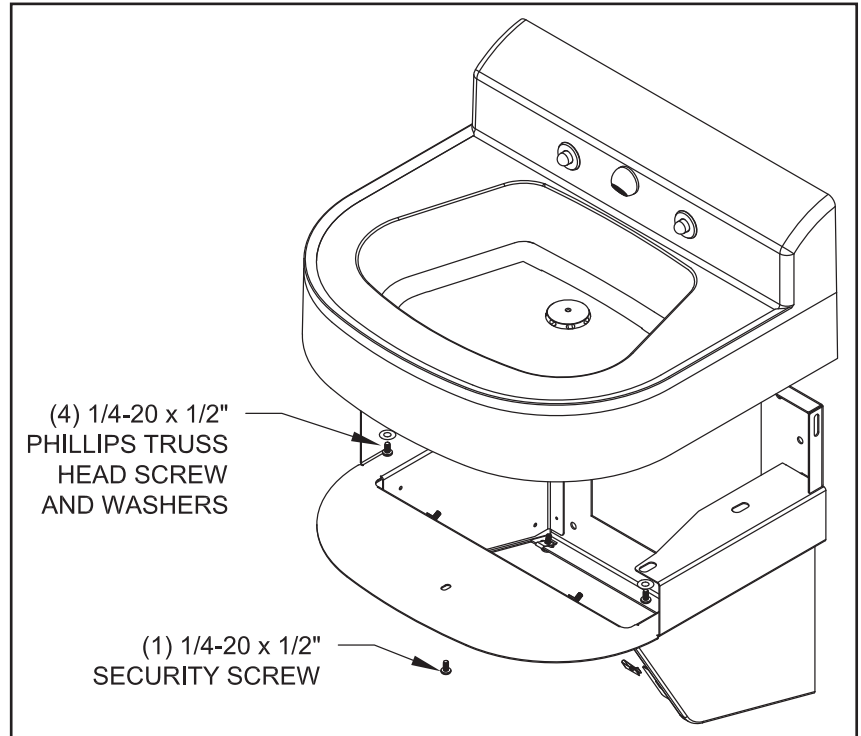

- 1.) Line up the brass threaded inserts on the bottom of the basin with the 4 holes on the top of the pedestal, secure with (4) 1/4-20 x 1/2" truss head screws.
- 2.) Secure front of pedestal with (1) 1/4-20 x 1/2" security screw.

Installation Instructions (cont.)

Step 5: Final Assembly

- 1.) Make all final plumbing connections to the drain and valve inlets. The lavatory is supplied with flex hoses (flex hoses have shut-off valves attached that should be connected to the supply inlets).
- 2.) Once all of the connections in the actuator housings are complete, locate the transformer.

NOTE: PLUG-IN TRANSFORMER (IF NEEDED) MUST BE USED WITH A GROUND FAULT INTERRUPT (GFCI) RECEPTACLE TO HELP PREVENT POSSIBLE ELECTRICAL SHOCK.

Note: For infrared systems see the start-up procedures and troubleshooting guide in the back of this manual.

- 4.) Test the system for leaks (both supply and waste).
- 5.) Place tinnerman nuts on the pedestal tabs.
- 6.) Set desired temperature with the adjustable mixing valve (see instruction near the back of this manual).
- 7.) Secure trap cover with (8) 3/4" security screws.

JACO Fitting Instruction



Note: It is not necessary to disassemble this fitting for application. Merely insert tubing to stop and tighten seal.

1. Cut tubing end squarely and remove the internal burrs.
2. Insert the tubing through the back of the nut all the way through the nut assembly to the tube stop in the fitting body (see illustration). If the tubing does not enter the nut easily, loosen the nut one turn and reinsert the tubing all the way to the tube stop in the fitting body.
3. Turn the nut hand tight.
4. Wrench tighten the nut $1\frac{1}{2}$ - 2 turns.
5. All nuts must be retightened when the system reaches projected operating temperature.

Note: To ensure proper assembly, tubing MUST be fully inserted into the fitting body all the way to the tube stop.

Note: Squeaking sound when tightening nut is normal. For pipe threaded connections, Teflon tape must be used.

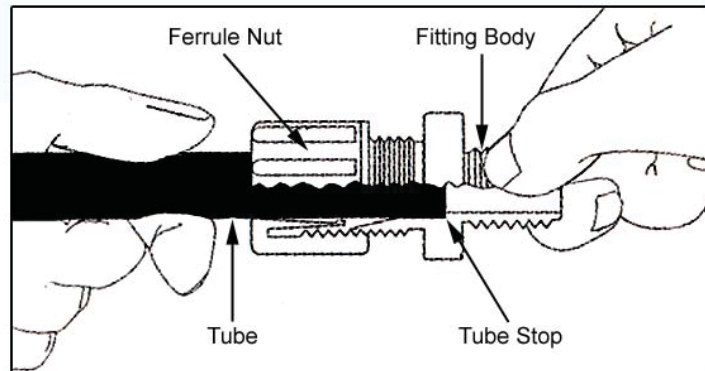
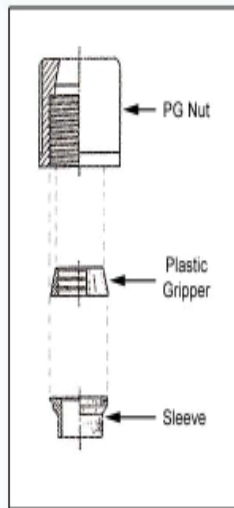

Adjustable Mixing Valve Installation

POWERS™

IS-P-e480

**HydroGuard® T/P Series e480
Lavatory Combination Valve**

Installation Instructions

To Install ■

NOTE: Installation should be in accordance with accepted plumbing practices. Flush all piping thoroughly before installation.

1. Locate a suitable place for the tempering valve. Valve should be accessible for service and adjustment and as close to the point-of-use as possible.
2. Connect hot and cold water to the supply valve using 1/2" NPT or 3/8" compression connections.
3. Connect outlet of tempering valve to fixture(s) using 1/2" NPT or 3/8" compression connections.
4. Turn on hot and cold water supplies. If any leaks are observed, tighten connections as necessary to stop leaks before proceeding.
5. Turn on fixture and allow water to flow for 2 minutes. Measure water temperature at outlet. If water is not at desired temperature, adjust as necessary.

Specifications ■

e480-001/2" NPT (Rough Bronze)
e480-011/2" NPT (Rough Chrome)
e480-103/8" Compression (Rough Bronze)
e480-113/8" Compression (Rough Chrome)
Capacity:4.0 gpm (15.0 l/m)
Approach Temperature:5°F (2.8°C) above set pt.
Max. Operating Pressure:125psi (862 kpa)
Max. Static Pressure:125psi (862 kpa)
Max. Hot Water Temperature:180°F (82°C)
Temp. Adjustment Range:	
.....	ASSE Type T/P: 95 – 110°F (43-48°C)
.....	ASSE Type T: 80 – 120°F (27-49°C)
Minimum Flow:0.5 gpm (2.2 l/m)
Checks:Integral
Construction:Cast Brass Body
Certified:CSA B125
ListingASSE 1016-1996 (Type T/P)
.....ASSE 1070

CALIFORNIA PROPOSITION 65 WARNING

WARNING: This product contains chemicals known to the State of California to cause cancer and birth defects or other reproductive harm. (California law requires this warning to be given to customers in the State of California.)
For more information: www.watts.com/prop65

Figure 1

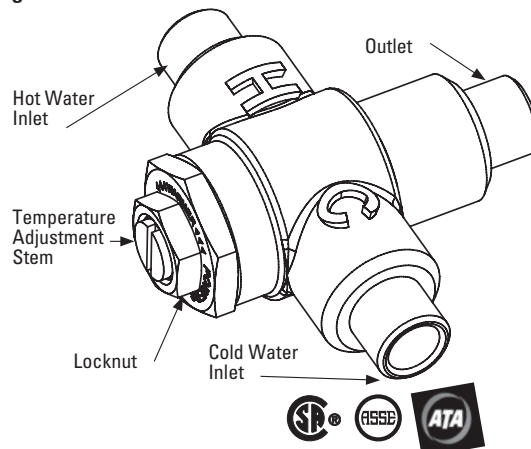
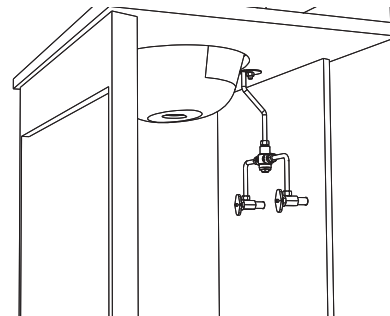

Figure 2: Typical Installation



To Adjust Temperature ■

1. Loosen locknut.
2. Turn on fixture and run water for at least two (2) minutes to allow supply temperature to stabilize.
3. Turn temperature stem counter-clockwise for hotter or clockwise for colder outlet temperature.
4. Tighten locknut to prevent accidental or unauthorized temperature adjustment.
5. Re-check outlet temperature.

Repair Kit ■

Motor Repair Kit.....480-270

Infrared Lavatory Sensor Installation

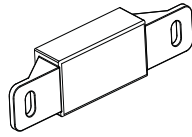

Willoughby Industries Infrared Lavatory Sensor Installation Instructions

DETECTION AND ACTIVATION

When the sensor detects a user, a slow flashing red light appears in the sensor window. After 1 to 2 seconds of detection, the light flashes rapidly and the sensor immediately activates the solenoid valve to begin water flow. The solenoid valve remains open as long as the user is detected. The solenoid valve turns off when the user is no longer detected. The sensor is set to activate the solenoid for a maximum of 30 seconds before automatically shutting off.

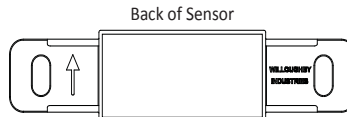

Figure 1

INSTALLATION AND REPLACEMENT

1. Disconnect 24Vac power at the transformer or fuse box.
2. Remove top cover to expose sensors.
3. Install new sensor. Make sure sensor arrow is pointing up. *See figure 1.*
4. Connect the red male power cable to the red female connector on the sensor. *See figure 2.*
5. Connect the black female solenoid cable to the black male connector on the sensor. *See figure 2.*
6. Replace top cover removed in step 2.
7. Reconnect power.

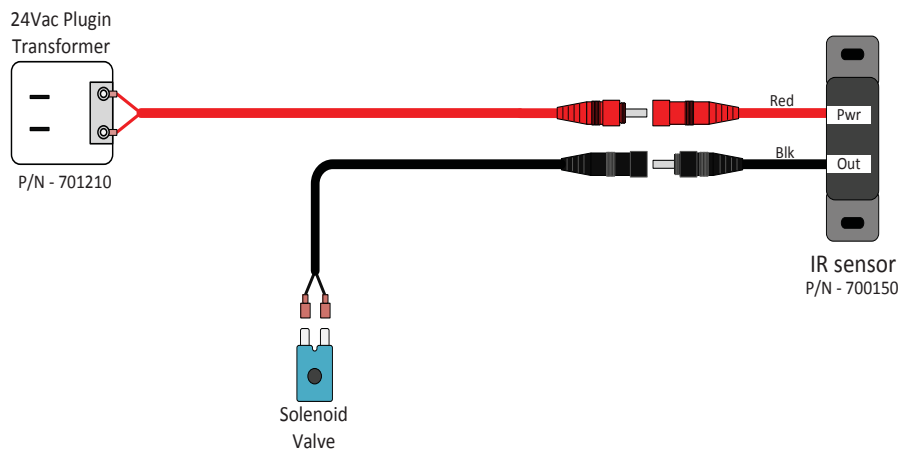
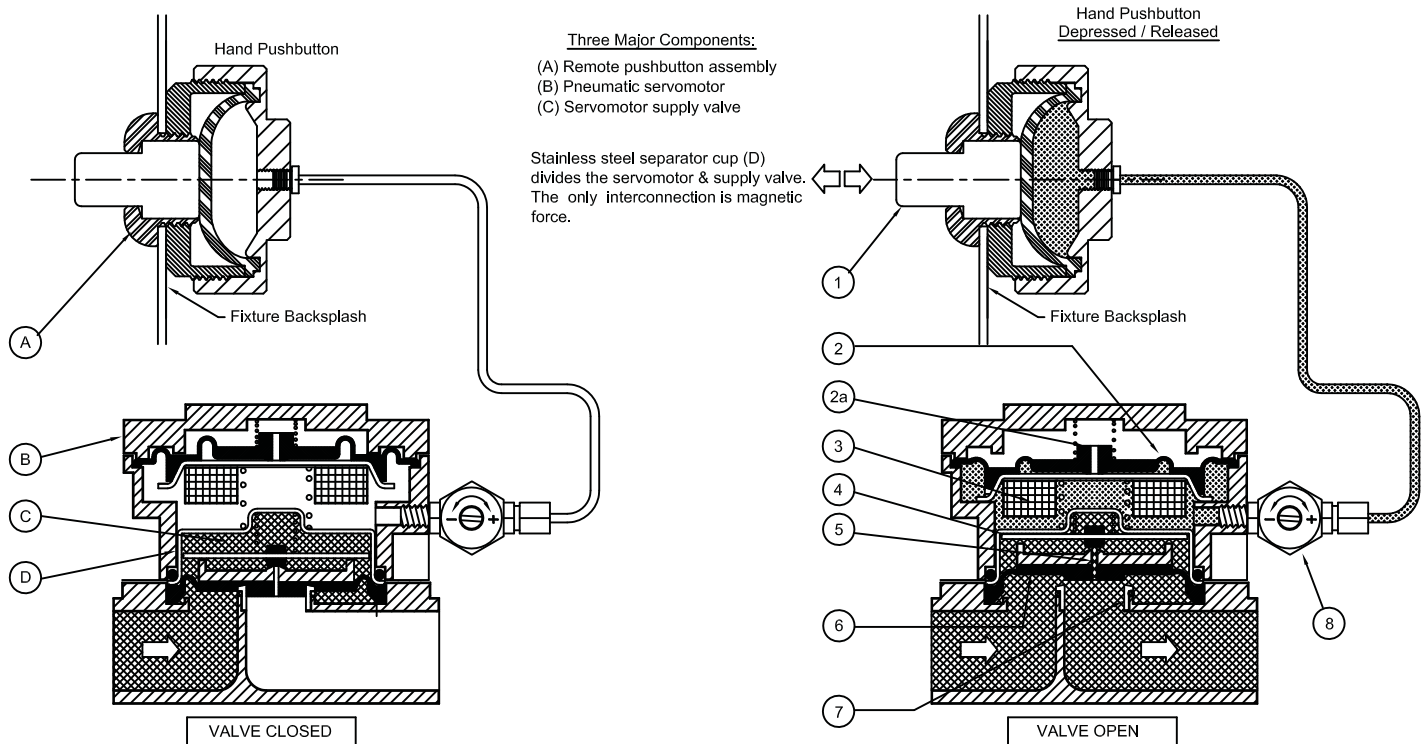

Figure 2

Pneumatic Valve Operation Details



Valve Closes: Air bleeds in through the timer (8) into the chamber below the actuating diaphragm (2). When the pressure in this chamber returns to normal, the diaphragm (2), and the magnet (3), are forced up. The pilot orifice plate (4) drops, covering the pilot orifice (5). Water pressure increases above the seat diaphragm (6), closing the diaphragm (6), against the seat (7).

Valve Opens: Depressing the button (1), forces air through the actuating diaphragm check valve (2a), and to atmosphere. Releasing the button (1), creates a vacuum below actuating diaphragm (2), and magnet (3). Diaphragm (2), and magnet (3), are forced down. Pilot orifice plate (4) is pulled up by magnet (3), opening the pilot orifice (5), bleeding off line pressure from above the seat diaphragm (6). Water pressure then lifts the seat diaphragm (6), off the seat (7), and opens the valve.

Valve Configurations

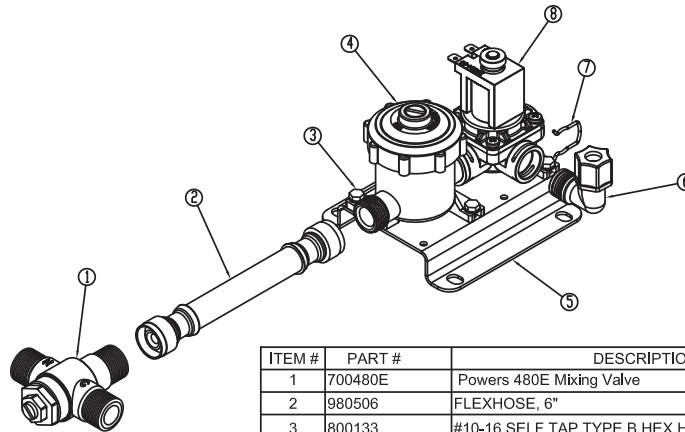

ITEM #	PART #	DESCRIPTION	QTY.
1	700480E	Powers 480E Mixing Valve	1
2	980506	FLEXHOSE, 6"	1
3	800133	#10-16 SELF TAP TYPE B HEX HEAD SCREW	4
4	980183	CHECKSTOP ASSEMBLY	1
5	980501	PM1 VALVE BRACKET	1
6	980600A	VALVE FITTING ASSEMBLY, 3/8" ELBOW	1
7	980140	SPRING CLIP	2
8	980408PR	E1L VALVE ASSEMBLY, RIGHT - PLUGGED PORT	1
9	980520	FLEXHOSE, 20" (NOT SHOWN)	2

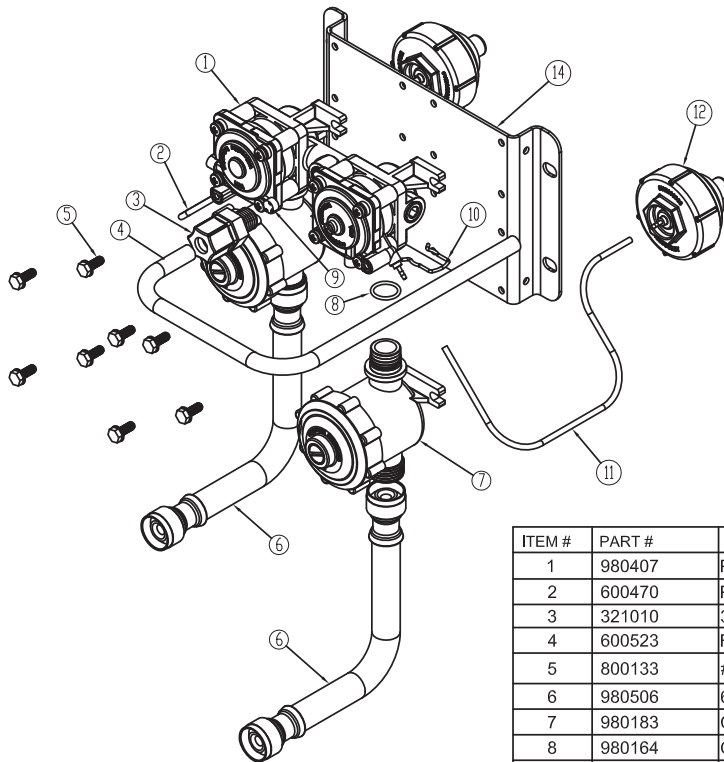

ITEM #	PART #	DESCRIPTION	QTY.
1	980407	PML2 VALVE ASSY	1
2	600470	PNEUMATIC TUBING 1/16"ID (RED)	1
3	321010	3/8" TUBE x 1/4" MPT CONNECTOR	1
4	600523	FLEXIBLE TUBING 3/8" (10mm) OD	1
5	800133	#10-16 SELF TAP TYPE B HEX HEAD SCREW	8
6	980506	6" SS FLEX HOSE	2
7	980183	CHECKSTOP ASSEMBLY	2
8	980164	O-RING, #015	2
9	380138	FLOW CONTROL 0.5 GPM (RED)	1
10	980140	SPRING CLIP	2
11	600475	PNEUMATIC TUBING 1/16"ID x 1/8" OD (BLUE)	1
12	600307	PNEUMATIC PUSHBUTTON	2
13	980502	PML2 Valve Bracket	1

Care and Maintenance

Solid Surface Care

Surfaces may be easily cleaned using conventional cleaning agents such as an ammonia based liquid cleaner, (glass cleaner).

Dry stains on a matte finish can be removed with a 3M Scotch-Brite gray scouring pad or a mild abrasive cleaner.

Burns or scorches can be removed by sanding with coarse grit sandpaper followed by finer grit (220) sandpaper. Follow sanding with a 3M Scotch-Brite gray pad (or equivalent) to match finish of sanding area to surrounding area. A final buffing may be required on polished surfaces. Accidental nicks or chips can be repaired with special patch kits available in all colors.

Avoid exposing surfaces to strong chemicals such as acetone's; paint removers and sulfuric acid or hydrochloric chemical cleaners. Exposure to strong chemicals may result in permanent damage to surfaces.

Stainless Steel Care

Stainless Steels are basically alloys of iron and chromium and are corrosion resistant. Stainless steel has a bright surface that is easy to clean and is free from oxides. Therefore, cleaning of stainless steel is relatively simple and easy if done on a regular basis.

Frequency of cleaning should depend on the rate at which the fixture becomes dirty. Remember that fresh (soft) deposits of all kinds are relatively easy to remove, while removing older (hard) deposits are much more difficult. Establish a cleaning SCHEDULE.

Routine cleaning should involve ordinary soap or detergent and water, applied with a sponge, brush or cloth. Baking soda, borax or any of several non-abrasive commercial cleansing agents can help hasten the cleaning action. after scrubbing, rinse THOROUGHLY and wipe dry.

DO NOT use common steel wool, scouring pads, scrapers, wire brushes, files or other steel tools to clean stainless steel. Such items will scratch the surface or leave small particles of iron imbedded in the surface, which will eventually rust and stain the surface - even appearing as if the stainless itself was rusting.

Certain chemical compounds, if used on stainless steel, can give the appearance of rust and if allowed to stand for long periods of time, can pit the surface of even stainless. Products containing hydrochloric acid, muriatic acid or potassium hydrochloride can ruin the surface.

Troubleshooting - Infrared Sensors

- I. Faucet does not function (red light does not appear when user steps in front of sensor)
 - A. No power to sensor. Make certain that power is on. Check transformer leads and connections. Repair or replace as necessary.
 - B. Willoughby 700150 IR Sensor not operating. Replace Willoughby 700150 IR Sensor.

- II. Faucet does not function (red light appears when user steps in front of sensor and solenoid does not click)
 - A. Debris in solenoid; disassemble, clean, and flush.
 - B. Solenoid not wired correctly; check solenoid connections.
 - C. Solenoid problem; replace solenoid.

- III. No water when activated (valve clicks)
 - A. Make certain that water is turned on.
 - B. Valve clogged. Clean or replace filter.

- IV. Very low flow or slow dribble
 - A. Check supply stop(s); open if closed.
 - B. Debris in filter; remove, clean, and reinstall.
 - C. Debris in aerator or spray head; remove, clean and reinstall.
 - D. Disassemble solenoid; clean and flush.

- V. Continues to run (with power on and red light flashing)
 - A. Non-permanent target in range after user leaves. Remove non-permanent target. If this target is a new permanent target (i.e., a new wall or partition), turn off 24 volt power for fifteen (15) seconds. Turn power back on and let the sensor complete start-up mode.
 - B. Sensor failure; replace sensor.

- VI. Continues to run (even with power disconnected)
 - A. Solenoid valve installed backwards.
 - B. Debris in solenoid, won't close properly; remove operator and clean. Reassemble in the same manner.

Troubleshooting - Electronic Valves

The two most common reasons an electronic valve does not operate properly are: (1) lack of power or (2) lack of water pressure. The following steps should be used as a guide in identifying the problem of a malfunctioning electronic valve.

- I. Lack of power
 - A. Verify that the 110V GFCI outlet has power
 - B. Check all connections to ensure they have been made correctly:
 1. Cable connecting the valve coil and the timer or IR sensor
 2. Cable connecting the timer and the pushbutton (Piezo only)
 3. Cable connecting the timing device and the 24VAC transformer
 4. The 24VAC transformer and the 110V GFCI outlet
 - C. If the valve is wired correctly, the solenoid will make a “click” sound indicating that the valve has been actuated. The electronic valve is actuated by either the piezo pushbutton or the triggering of the infrared sensor (see the Start-Up Instructions for Infrared Sensors in this manual).

- II. Lack of water pressure
 - A. Check the supply to the rough-ins
 - B. Make sure the screwdriver stops are in the open position
 - C. Water pressure needs to be above 20psi to operate the valve
 1. If the water supply pressure is above 20psi but not exiting the valve:
 - a. Clean any debris from the screen on the inlet side of the solenoid valve body
 - b. Remove the screws on the valve body and clean any debris from the diaphragm

After all of the above steps have been followed, if there is still no water coming out of the spray head, there may be a damaged or defective part (see installation notice in the front of this manual).

Troubleshooting - Pneumatic Valves

- I. Valve will not open or deliver water
 - A. Check the plastic tubing that runs from the pushbutton actuator to the pneumatic valve for air leaks.
 - B. Make sure the checkstop on the supply to the valve is fully open. Do not partially close the checkstop for any reason as it is not a throttling valve. The checkstop should be fully open (normal operation) or fully closed (when servicing the valve).
 - C. Close checkstop and then inspect the strainer in the supply line (installed after the checkstop) to make sure the strainer is not blocked or partially blocked, prohibiting water flow.

- II. Valve will not shut off
 - A. Separate valve motor from casting by removing the four (4) #8 screws.
 - B. Inspect the water diaphragm assembly to see if bypass hole in diaphragm is blocked. Remove any debris by blowing on diaphragm or using force of air. Do not use any tool (such as straight pin) to remove any debris. Enlarging the hole will shorten or make for erratic cycling.
 - C. Check the metering screw on the timer assembly to make sure the adjustment screw is not closed too tightly. To reset, back out adjustment screw (counterclockwise) about 1-1/2" turns, and adjust for the desired cycle.

- III. Valve continues to trickle or partially deliver water after cycle is over
 - A. Inspect seating area on valve base to make sure no debris, pitting, or scoring is present.
 - B. Clean seat or replace seat as necessary.
 - C. Inspect seating area of diaphragm for debris, clean as necessary. If debris has caused permanent indentations in the rubber, it may have to be replaced.

After all of the above steps have been followed, if there is still no water coming out of the spray head, there may be a damaged or defective part (see installation notice in the front of this manual).

**DRAWING: General Dimensions
and Rough-in Detail**

 <p>WILLOUGHBY INDUSTRIES, INC. INDIANAPOLIS, INDIANA</p>	<p>TITLE: BEHAVIORAL HEALTH LAVATORY MODEL# WBL-2320</p>		<p>DRAWING #: P129001A</p>
	<p>MATERIAL: AS NOTED</p>	<p>DRAWN BY: TRB</p>	<p>DATE: 10/18/12</p>
<p>DIMENSIONS ARE +/- 1/4" EXCEPT AS NOTED</p>	<p>SCALE: NONE</p>		

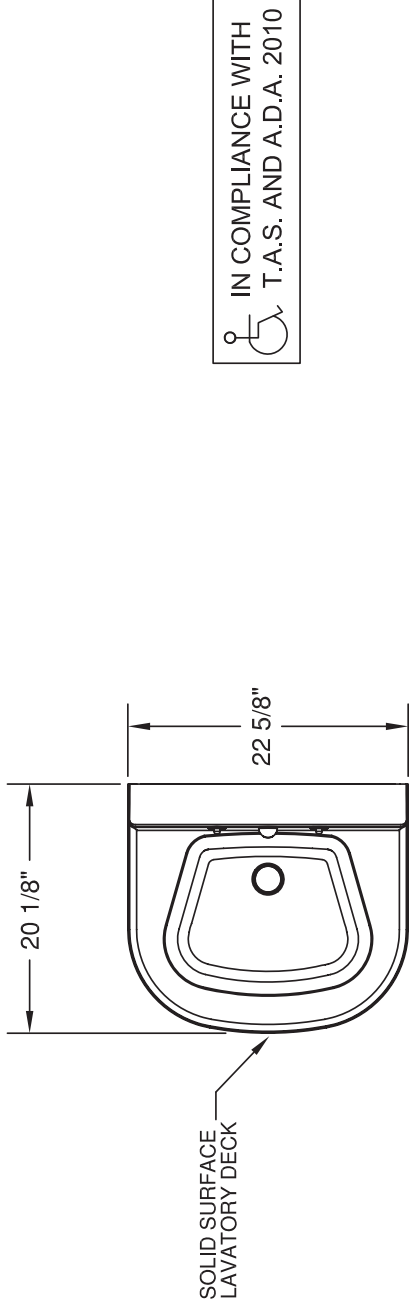

IN COMPLIANCE WITH
T.A.S. AND A.D.A. 2010

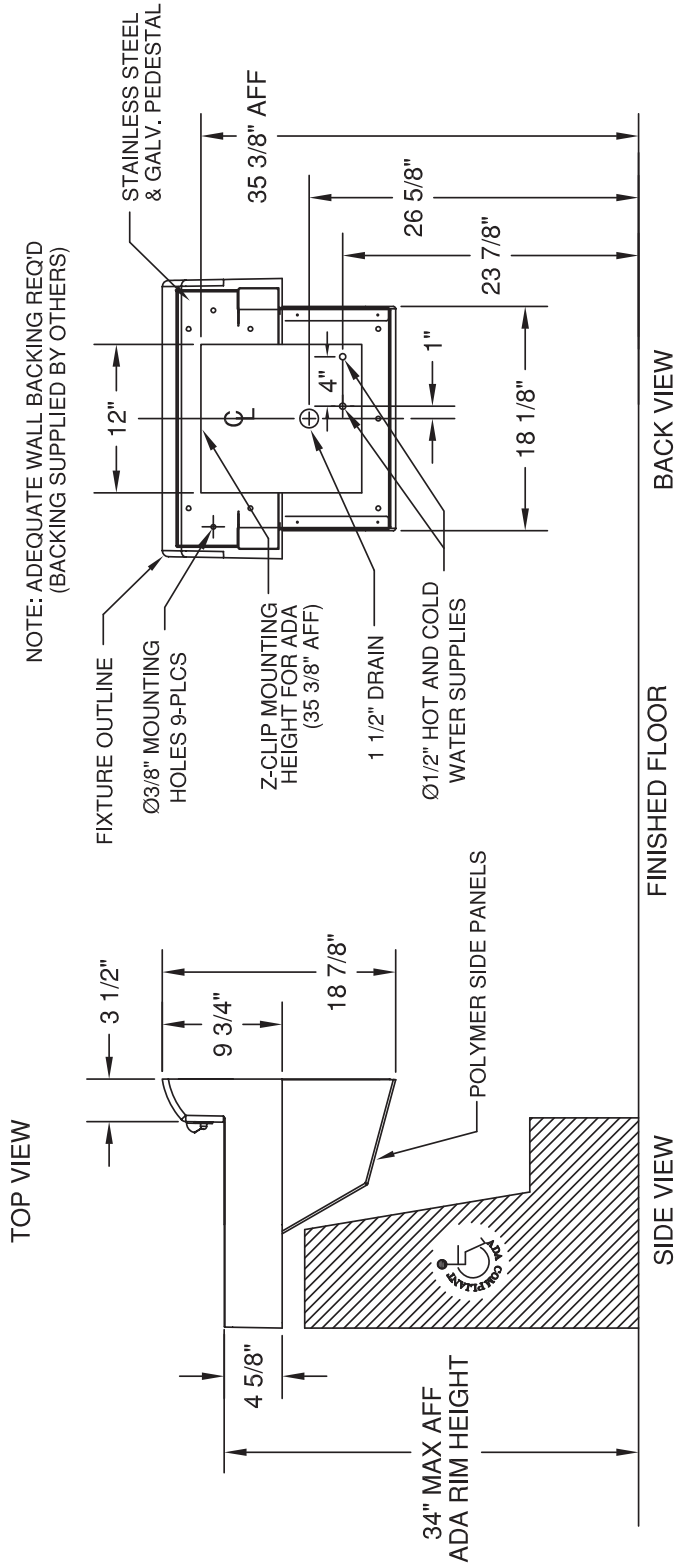
Warranty

Solid surface products are a homogenous blend of resins, mineral filler and colorant manufactured for panels, molded and/or shaped products and components. Solid surface products provide a luxurious appearance with the durability of stain proof, impact resistant, burnresistant material with the ease of maintenance and cleaning.

Willoughby Industries, Inc. warrants to commercial and institutional purchasers only that each unit will be free from defects in workmanship and materials under normal use and service upon the following terms and conditions. The period during which components are warranted as follows:

1. Solid surface components are warranted for 2 years from date of shipment.
2. All other components warranted for 1 year from date of shipment.

This warranty does not cover installation or any other labor charges and does not apply to any components damaged by accident, abuse, improper installation or improper maintenance. This warranty does not cover any installation that did not comply with national, state and local building, plumbing or electrical codes. The warranty is limited to replacing or repairing at manufacturer's option, transportation charges prepaid by the purchaser, any component or part which upon our inspection shall be deemed as defective within the limitations of this warranty. The replacement or repair of defective units as stated in this warranty shall constitute the sole remedy of the purchaser and the sole liability of Willoughby Industries, Inc. Willoughby Industries, Inc. shall not otherwise be liable under any indirect damages caused by defects in the repair or replacement thereof.

This warranty only extends to commercial and industrial purchasers and does not extend to any others, including consumer customers of commercial institutional purchasers. This warranty is in lieu of all other warranties, expressed or implied, including implied warranty of merchantability or fitness for a particular purpose or otherwise.