

LOCKR

HASP

HASP LOCK
FOR LOCKERS



ojmar

LOCKR HASP

REF. 039 

Designed for lockers up to 20 mm thick as well as for metal lockers.

Its robustness, high resistance to humidity and an easy to mount system offer a simple and effective solution for heavy duty use in collective installations.

Equipped with anti-rotation system

Optionally with backplate if the customer wants to use another system in the future (Coin lock, OTS proximity lock, etc.).



WOOD



METAL

HASP LOCK	WOOD	METAL
TECHNICAL SPECIFICATIONS		
AVAILABILITY	RIGHT Code No 039.0D0045CR LEFT Code No 039.0D0045CR	RIGHT Code No 039.M0D0045CR LEFT Code No 039.M0I0045CR
FIXING	Screwed.	With nut.
ROTATION	180°	180°
CLOSING	With padlock of up to 8 mm in diameter.	With padlock of up to 8 mm in diameter.
FINISHES	Chrome.	Chrome.
MATERIALS	Lock in zamak and Cam in steel.	Lock in zamak and Cam in steel.
MECHANICAL REQUIREMENTS	No. of cycles: 60,000 cycles according to the LGA guidelines 48 hours in salt spray test. Resistance: 50 kg/f.	No. of cycles: 60,000 cycles according to the LGA guidelines 48 hours in salt spray test. Resistance: 50 kg/f.
ACCESSORY OPTION	Backplate for OTS and coin lock footprint. Code No 039.002PN.	-
PADLOCKS	Padlocks available on request.	Padlocks available on request.
TECHNICAL DRAWING	Drawn position: RIGHT HAND.	Drawn position: RIGHT HAND.

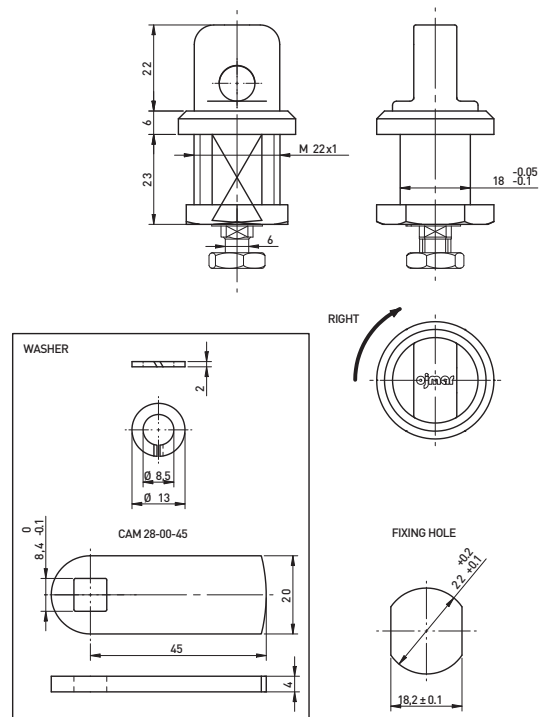
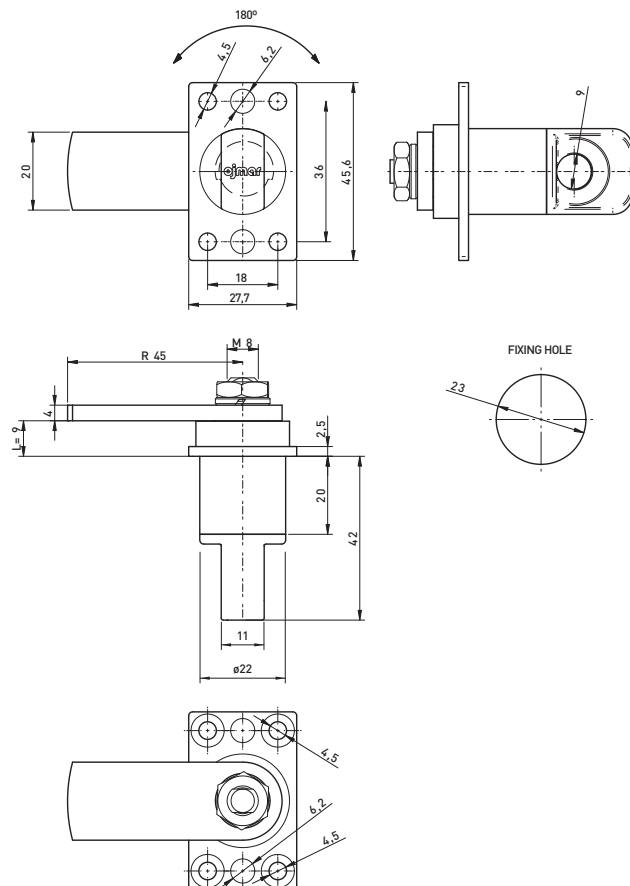

REMARK: Other cams available on request



OJMAR, S.A.

Pol. Ind. de Lerun, s/n • 20870 Elgoibar • España

Tel: +34 943 748 484 • Fax: +34 943 748 490

www.ojmar.com

