



# Product Guide

Roller Shade Collection



# Contact

**Address:**

QMotion Shades  
3400 Copter Road  
Pensacola, FL 32514

**Website:**

[www.qmotionshades.com](http://www.qmotionshades.com)  
[qmotioninfo@qmotionshades.com](mailto:qmotioninfo@qmotionshades.com)

**Phone:**

Customer Service Number: 877.849.6070  
Fax: 850.208.3409

**Social:**

<http://www.twitter.com/qmotionshades>  
<http://qmotionblog.com/>  
<http://www.facebook.com/QmotionShades>



## Table of contents

Features.....	1
Options.....	2
Shade Information.....	3
Low Voltage Transformer Information.....	4
Shades.....	5
Qlink Shades.....	6
Mounting Brackets.....	7
Fascia.....	8
Battery Life.....	9
Non-Motorized Shades.....	10
Cassette Shades.....	11
Fabric Measurement Listings.....	12
Fabric Color Listings.....	25
Accessories.....	28
Controls.....	29
Wall Docking Stations.....	32
Customer's Own Material (C.O.M.).....	33
Special Ordered Material (S.O.M.).....	33
Shade Measurement Instructions.....	34
Order Form Guide/Form.....	36
Reference Information.....	39
Setting Hembar Position.....	40
Advanced Remote Settings.....	42
Brackets (illustrations).....	45
Cassette and Qlink.....	54
Fascia (illustrations).....	55
Qbasic Fascia (illustrations).....	60
Copyright Notice and Disclaimer.....	61
Limited Warranty.....	62





# Features

## QMotion® offers state-of-the-art natural light control with the following benefits:

### Several different control options

- QMotion® Shades offer the convenience of moving the shade up or down, stopping at any of the top, the bottom, three programmable intermediate stops, or anywhere in between; all with the ease of a button press.
- *Lose your remote? No problem!* QMotion® shades can be moved up or down manually with no remote control. Simply give the shade a gentle pull to get them started.
- *Interested in reducing your energy bills?* The programmable timer remote can be set up to move your QMotion® shade automatically. Automate your shades by time of day, day of week, sunrise, or sunset. Create six distinct settings and let the shades do the rest.
- *Want to control multiple shades with just one remote?* QMotion® multi-channel remote controls 6 individual shades or 6 groups of shades all with one remote control. Each channel can have an unlimited number of shades programmed to it.

### Unmatched quietness

- QMotion® engineers developed a shade with whisper quiet operation for a beautiful and peaceful experience.

### Distinctive designs

- Generous fabric collection of light filtering, decorative and beautiful blackout materials.

- Industry leading light gaps on the sides of the shades as small as 1/2" gap on each side, providing the most uniform and highest level of window coverage.

### Unparalleled simplicity

- QMotion® automated shades are powered by a low voltage power supply, or an internal pack of standard D-cell batteries. Low voltage power can also be backed up, for uninterrupted operation.
- Our low voltage option allows shades to be powered either individually with a single transformer, as group of four, or with a power panel for supplying as many as 16 shades with power.
- Batteries can last up to five years or more, dramatically reducing maintenance cost and adding convenience. (Shade size and usage will determine actual battery life.)
  - No cords
  - No electrician
  - No wires
  - No special tools





## Options

### **QMotion® advanced shade solutions allow for a customized experience.**

#### The look you want

- QMotion® shades offer *several choices of fascia* to conceal the top of the roller shade. Choices include a painted fascia and a fabric wrapped fascia.

#### The design you need

- Shades come in *either standard roll or reverse roll*. Standard roll shades have the fabric rolling off the back of the roll, close to the window, while reverse roll shades come off the front of the shade roll, and are further from the window glass. Reverse roll may be a preference for design purposes, or may be needed to permit the shade to lower clear of window obstructions.

#### The number you want

- Our *dual shade system* allows users to choose a combination of two shades on the same window. Often used with a light filtering fabric in the front and with a room darkening fabric closest to the glass, QMotion® dual shades are an excellent way to double treat a window in a small space.



#### The choice you prefer

- Transformer low voltage power supply is a wired power solution for those who want the benefits of QMotion® Automated shades with a connection to the facility electrical system. Available in a single unit, or one which can power up to four shades or in a panel solution for as many as 16 shades. Low voltage shades deliver all the benefits of QMotion® technology.
- Battery powered QMotion® Shades offer the same benefits as low voltage powered, and add in the ability to install in difficult situations as well as function in the absence of electrical supply. Because QMotion® battery powered shades use an internal battery pack, there are no visible battery packs or wires to hide or see.

#### Customization that's right for you

- Choose from our assortment of remote controls. Among the choices is our programmable timer control which allows for setting of times for unattended shade movement or our multichannel remote to control various shade groups from a single hand held transmitter. All transmitters fit on our magnetic wall docking stations, and may be secured in place using our wall station adapter.
- As our programming is simple, all shades arrive ready to "learn" to your remotes. A shade may be controlled by as many as 12 different transmitters.
- Combine groups and transmitters for your convenience. A channel can be for a single shade or a group of shades, and various groups can be programmed to suit the space.





## Shade Information

**Finally, the luxury and safety of automated shades, completely free of cords and wires, are accessible to everyone.**

### Order specifics

- Shades ship complete with brackets and batteries, as needed, ready to install.
- Shades may be specified standard or reverse roll.
- If desired, a 24v low voltage transformer power option may be specified.

### Size limitations

- Minimum width 22<sup>1</sup>/<sub>2</sub>" with batteries, 17<sup>1</sup>/<sub>2</sub>" with low voltage power.
- Maximum width 144".
- Maximum height 144".
- Consult fabric tables for available fabric heights, widths and more specific size availability.

### Roll size

- Roll up diameter or RUD is determined by the size of the shade and fabric chosen.
- Extra length of material will be added to the height of the shade in order to allow the fabric to wrap around the tube when fully rolled down.

### Fabric orientation and size

- All shades ship with fabric oriented in the vertical roll direction from the mill.
- If a shade in a group is railroaded, you have the option to railroad all shades the group to match.
- Railroading is available on select fabrics only.
- Seaming is available in all fabrics.
- The seam will be placed near the top of the shade unless specified otherwise.

### Side gaps

- 1/2" industry leading side gaps are uniform on each side of the shade. Fabric width will be 1" narrower than the specified bracket to bracket dimensions.

### Tube and hembar size

- Tube and hembar diameters vary depending on the height and width of your shade.
- Hembars are available in painted or fabric wrapped. Paint colors are white, sand, silver, bronze and black.
- All roll up diameters 2.6 or less ship with 1/2" hembars.
- Shades shipped with roll up diameters greater than 2.6 ship with 3/4" diameter hembars.
- A 3/4" hembar is compatible with 2.5" brackets and may be noted as a substitution on the shade order form.

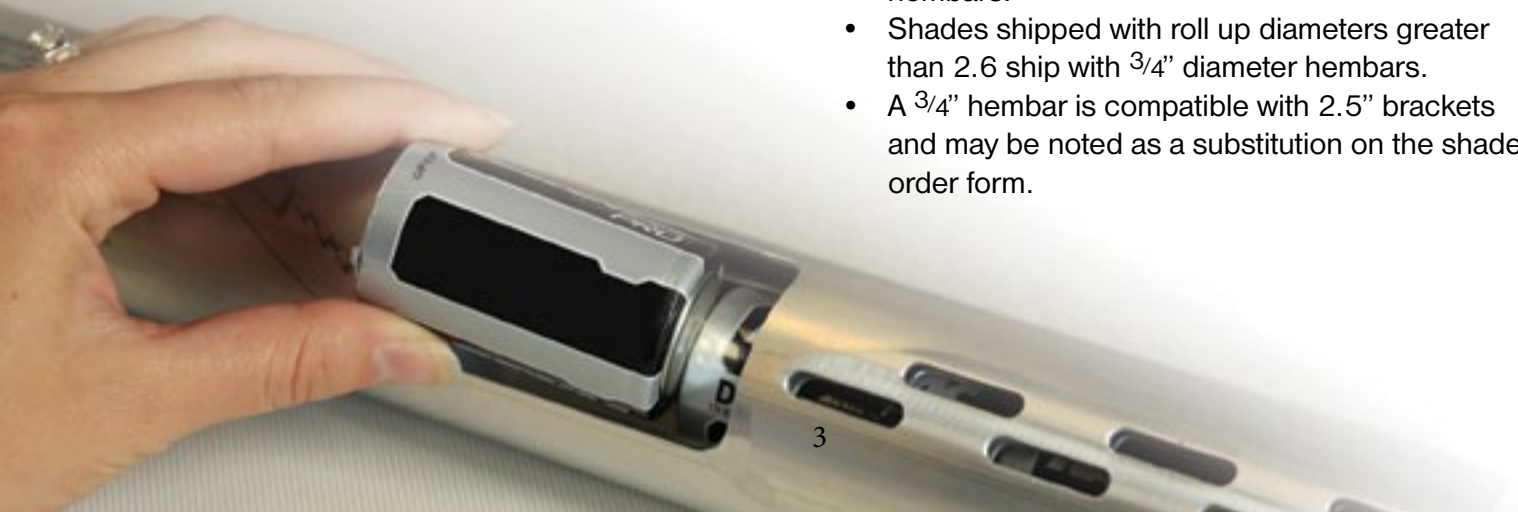



## Low Voltage Transformer Information

QMotion® Low Voltage shades offer all the same features of QMotion® Battery powered shades, and are compatible with fascia as well as controls.

- Battery tube is replaced with transformer leads
- Each shade comes with a 24" wire lead.
- Tube is configured to convert low voltage into the proper level to power the shade.
- Power supply options are available to power one shade or multiple shades.
- The power supply can be at the header with the shade, on the floor near the shade or in an equipment room several hundred feet away from the shade.
- In Single Shade Option, a plug-in power supply provides 24v DC to the shade.
- Low voltage single shades are controlled with the same wireless RF remote as the battery option shades.
- With the Low Voltage Distribution Box the power supply is designed to distribute the appropriate power to as many as four shades.
- The power distribution panel sends power individually up to sixteen shades. The panel also provides protection against short circuit or overload to individual shades.

- 24v to 48v power input accepted.
- QMotion® Low Voltage shades continue to offer the unique and patented manual override system.

*\*Electrical Panel Box system may be equipped with a customer supplied battery back up system, in the case of a site power event.*

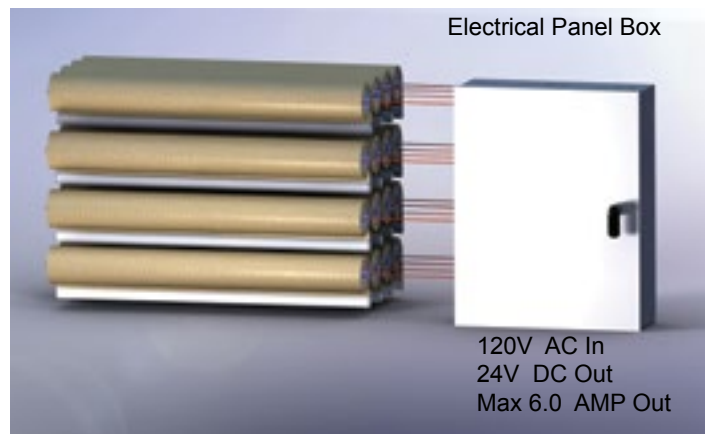

## Wire Gauge Requirements

QMotion® does not supply the wires from the transformer to the shades. Recommended minimum wire gauge requirements for distances between power supply and shade or distribution box and shade are as follows for the required 2 conductor cables:

Wire Length (ft.) 24v	Min. Wire Gauge
1500-3000	12
1200-1500	14
700-1200	16
500-700	18
0-500	20

**\*\*Consult your local electricity provider or state regulatory agency for their guidelines regarding cable installation. Comply with all building codes, safety regulations and legal standards.**

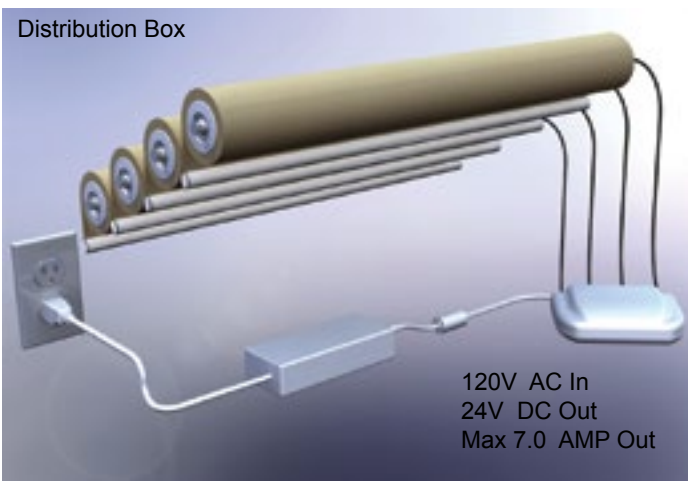



## Shades

### **The next generation of QMotion® Shades takes automated window shades to a higher level.**

#### 2<sup>nd</sup> Generation QMotion® Shades

The new design of QMotion® delivers a simpler, sophisticated automated shade that offers both ease of use and dependability.

**Easy Battery Replacement** - By placing the access port for the batteries in the shade tube wall, you can now change the batteries without having to remove the shade from the brackets. The battery life is up to 5 years, depending on shade size and usage.

**Easy Fabric Removal and Installation** - A snap-on spline is attached to the fabric and can be pulled off and snapped on to the shade tube. The spline that attaches the shade to the tube permits the rollershade fabric band to be easily removed for cleaning, maintaining and sanitizing OR replacement of the fabric altogether. Demounting the tubes or brackets for cleaning is unnecessary.

- Low voltage wired shades can accommodate left or right side connection.
- Longer battery life.
- Extended range and enhance responsiveness to transmitters.
  - 30 feet or more in most applications (each installation is different, and environmental factors may effect results.)
- Improved functionality with remotes.
- Advanced electronics are designed to be more responsive and durable.
- Improved programming ease.



#### Side Channels and Sill Rail

- Side Channel and Sill Rail now offer a better light control solution by covering the sides and bottom.
- Side Channels are 2" wide, and the fabric travels inside them with a light blocking wool pile to assist with better light control.
- Side Channels and accompanying Sill Rails come in any of the 5 standard colors. (White, Anodized, Sand, Bronze, or Black)
- Sill Rail is "L"-shaped, and can be oriented to show either 1 1/8" or 2" face toward room.
- Fits into fascia to ensure maximum room darkening.
- Max size is 96 x 96 (depending on fabric).
- 1/2" hembar only - no fabric wrapped hembar.





# Qlink Coupled Shades

**The next generation of QMotion® Shades takes automated window shades to a wider level.**

## Qlink

By using the Qlink coupling system, shades can cover spans as wide as 30 feet with a single motor. The linked shade's unique coupling system supports 3/4" minimum light gap and angles up to 40 degrees.

- Multi-window coverage without wiring, or use our low voltage system.
- Manual override option - shade can be operated manually at all times.
- Shades retain long battery life.
- Adjustable installation brackets for proper shade leveling.
- All other QMotion® features and benefits continue to apply.
- Cover with QMotion® automated fascia.
- Qlink coupled shade mounting brackets are compatible with standard QMotion® mounting brackets and independent fascia.
- For inward facing angles (like bay windows), light gap can be smaller by using a reverse rolled system.



## Ordering Information

- Standard roll has motorized shade on left.
- Reverse roll has motorized shade on the right.
- All shades must use same fabric.
- The shades must have same height.
- Choose either White or Black for Qlink.
- Choose straight or select the adjustable angle bracket for angles of up to 40 degrees.
- Bracket enables adjustments for height and depth.
- "Sprung shade" refers to the opposite end from the motorized shade.

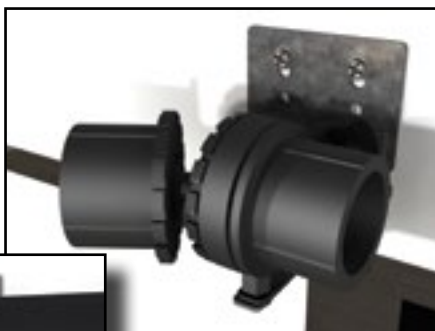

Battery Decreased Life	
Straight	0%
Max Angle	15%

Total Shade	
Minimum Battery Shade Width	32 inches
Minimum Low Voltage Shade Width	17 Inches
Minimum Inner Width	17 inches
Minimum Inner Sprung Width (application dependent)	17 inches
Minimum System Width	49 inches
Minimum Number of Panels	2
Maximum System Width	30 feet
Maximum Height (see fabric tables)	120 inches
Battery Available	Yes
Low Voltage Available	Yes
Fascia Available	Yes
Light Gap When Straight	3/4 inches



## Mounting Brackets

**Elegant fabrics, clean lines and modern finishes create natural beauty for every window.**

### Seven styles

- There are seven different mounting brackets offered depending on application requirements:  
2.6 Universal                      3.3 Universal  
2.5 Dual Shade                    3.7 Dual Shade



- The numerical designation represents the maximum size roll diameter the bracket can support. 2.6" brackets accommodate roll sizes from 2.0" - 2.6". 3.3" brackets accommodate roll sizes from 2.6" - 3.3".

### Roll size guidelines

- Roll size is determined at the time an order is quoted and is dependent on material thickness, and the height of the shade. Fabric listing tables provide the maximum shade height for 2.6" brackets and 3.3" brackets depending on fabric type and width of shade.

### Default brackets

- Non-fascia shades ship with universal brackets.
- Outside mount shades ship with outside mount brackets.
- Pocket applications are best served with our fascia. Please note bracket requests on order form.
- Dual shade applications ship with dual brackets. 3.3" universal bracket is shipped for all outside mount applications with roll diameters greater than 2.6".
- Verify bracket dimensions in the space where the shades will be installed. If the brackets can fit, then the shade will fit, be installed and adjusted with ease.

### Reverse roll brackets

- All brackets are engineered to accommodate both reverse and standard roll.

### Fascia compatibility

- All brackets are compatible with fascia treatments.
- CAD data in dwg and pdf format is available at [www.qmotionshades.com](http://www.qmotionshades.com).





## Fascia

### Fascias add a special finishing touch.

Including fashionable, color-coordinated fascias will enhance both the form and function of your QMotion® Shades. Easily mounted either inside or outside the window width, fascias attractively conceal the shade system while adding to the light protection your shades were designed to provide. So they're pretty and practical, all in one.

- Choose from five standard colors: White, Silver, Sand, Bronze, and Black or fabric wrapped to match your shade.
- Fabric wrapped options cover the entire front face and bottom face of fascia.
- All fascia orders include color-coordinated endcaps.
- All fascia include an integrated light-blocking strip at the top for full finish and optimal light management.

- Some fabrics are not available to be wrapped on Qmotion® Fascias. This is due to their inability to be attached in an appropriately aesthetic fashion. At the time of this writing, fabrics in our current sample collection which are not available with fabric covered fascia:

Avila	Chantilly	Edessa
Infinity	Tones Blackout	Umbr

Please contact Customer Service for current details.

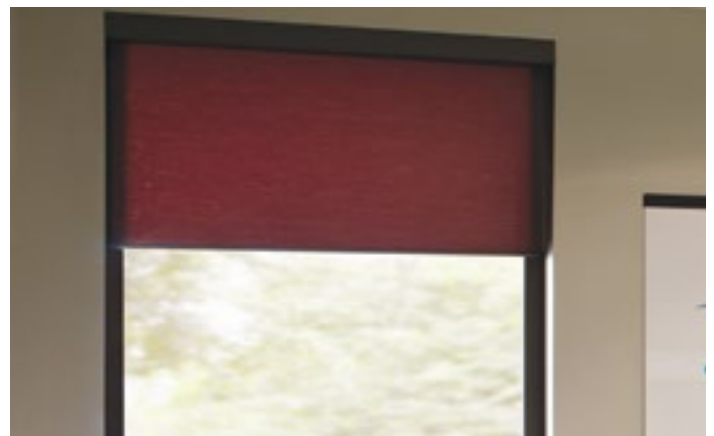
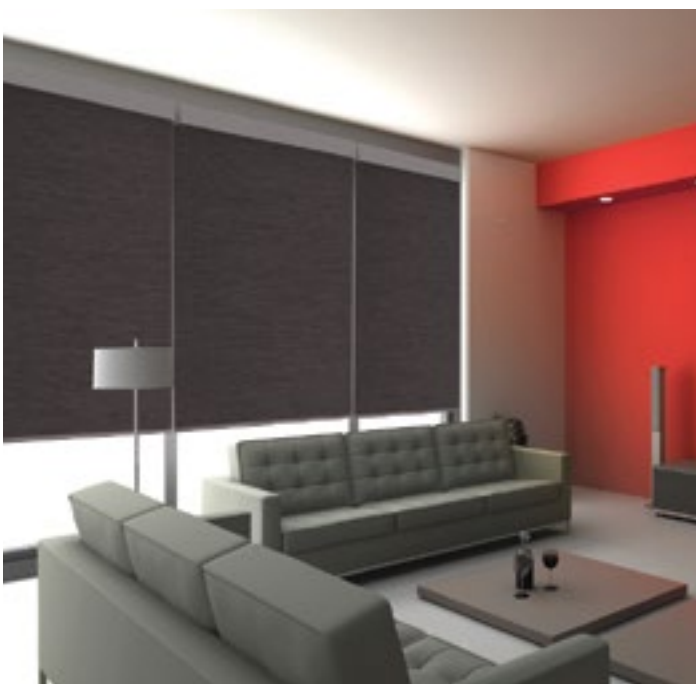

### Pocket Closure

- To conceal the lower front of a pocket installation, Qmotion® offers the Pocket Closure system
- This simple two part system installs easily, and conceals the front bottom of installed shades.
- Sections are cut to size, and available up to 12.5 foot lengths, and the Closure sections are available in either 2" or 3" depths, for the best possible match in the design.
- Available in white only.



# Battery Life and Range Expectations

**QMotion® shades offer the longest battery life in the industry.**

QMotion® Shades lead the industry in battery life

- Our shades use D size alkaline batteries, while others use AA batteries which have fraction of the capacity. D size batteries have 7 to 8 times the capacity. We have patented the technology to put the batteries inside the tube providing superior aesthetics with no power wires or antenna showing.
- While balance is important, most shades are not moving most of the day. The shade must be ready to accept a command 24/7, that means the shade must be awake and listening for your commands at all times. QMotion® shade engineers have painstakingly designed software and hardware that minimize battery usage when the shade is not being used. Our technology stretches battery life, resulting in industry leading time between battery changes.

- QMotion® uses patented techniques to manage the weight of the shade as it is lowered. Because of this, it takes very little energy to run our shades up and down, meaning very low usage of the batteries.
- Battery life is dependent on shade usage and shade size. Larger shades, when used more, will have lower battery life expectancy when compared to smaller shades used less frequently.
- The graph below indicates the relative battery life of different sizes of shades and different amounts of usage of each.

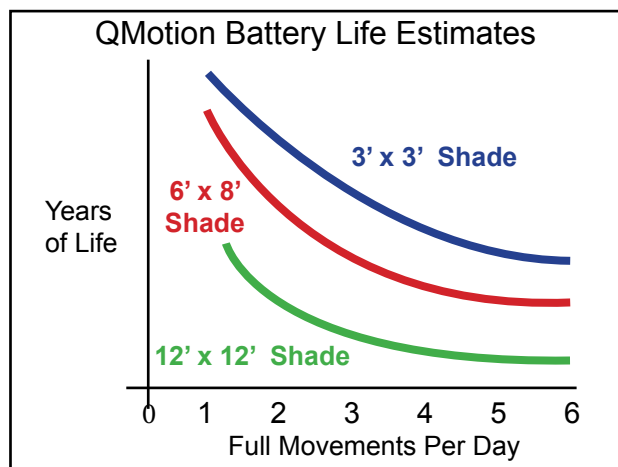

## Distance from shade to be controlled - (2nd Generation)

QMotion® transmitters are expected to work from over 30 feet away. While your individual results will vary, and may be less in some environments, many customers have reported even better results.

The QMotion® Timer Remote is a special function device and under FCC guidelines may not transmit at the same power as others. Range for this is typically over 10 feet.

We recommend the use of a Qrelay when the transmission range of a device is not sufficient.

Transmitter	Normal (ft)
Single Channel	30
Multi Channel	30
USB Timer	10
Qconnect	50
Qrelay	30

\*\*\*Remember each installation is unique, height of the window, interference and other factors may effect this expectation.\*\*\*





## Non-Motorized Shades

**Simplicity, elegance, and affordability from QMotion® coordinates a beautiful look.**



Qfree shades are identical in look to QMotion® Automated Shades. Each Qfree shade is designed with the same quality engineering and offers exceptional child safety through the lack of continuous cords.

Pull tassel available in black or white. Request on order.



Each Qbasic shade comes standard with a chain tensioner that meets current industry safety requirements.

Qbasic clutch type manual shade is anything but your basic shade. Qbasic delivers the styles you want that surpass similar clutch type manual shades.

- Fully adjustable upper limit
- Integrated braking system
- Fully compatible with QMotion® automated shades and brackets
- Shades over 22 1/2" wide may, at some time, be motorized in the future for a surcharge (t.b.a.)
- Minimum width of 14" wide
- Shades up to 120" wide x 120" high, check fabric charts for specific fabric capabilities
- Easily positioned to be standard or reverse roll
- Easy fabric change with spline

- Easy pull gear reduction clutch allows for smooth and lower force operation
- Reversible fascia allows for adjustment to standard or reverse roll
- Minimum width of 7"
- Shades up to 120" wide x 144" high
- Quick roller tube release from end bracket for easy removal
- Standard hi-tensile strength plastic chains
- Stainless steel or nickel plated chain upgrade available

### Qbasic Specifications

Clutch Type	QB-17	QB-28	QB-17	QB-28
Tube Diameter	1 1/2" Standard	1 1/2" Snap On Fascia	2" Standard	2" Snap On Fascia
Maximum Width	108"	108"	120"	120"
Maximum Height	144"	144"	144"	144"
Maximum lbs	17 1/2	28 1/2	17 1/2	28 1/2
Light Gap	9/16"	9/16"	9/16"	9/16"
Minimum Inside Depth	3 3/16"	3 9/16"	3 3/16"	3 9/16"
Tube Diameter	1 1/2"	1 1/2"	2"	2"
Gear Reduction	20%	30%	20%	30%
Snap On Fascia Available	No	Yes	No	Yes
Independent Fascia Available	Yes	Yes	Yes	Yes





## Cassette Shades

**The next generation of QMotion® Shades takes automated window shades to a higher level.**

### QCassette

QMotion® motorized Cassette Roller Shades are powered by the same innovative battery saving technology used in all of our roller shades. This Cassette was designed for a soft elegant look with easy installation in mind.

- Fully enclosed shade system covers top and back with aluminum, and shade rises fully into cassette.
- Installation of this single shade cassette is literally a “snap” with two simple spring clips needed.
- Light blocking wool pile integrated into the top for more complet finish and better light management.
- Curved front cover design.
- Coordinated front cover in 5 standard laminated colors. White, Black, Bronze, Sand and Silver.
- Painted or fabric wrapped hem bar.
- Easy access to batteries in the shade tube through pivoting front cover.
- Works with all QMotion® controls.
- Compatible with QMotion® Automated and Qfree shades (pull tassel recommended with Qfree shades in cassette.)
- Available on shades up to 120 inches x 96 inches, with limited fabric exceptions. Max RUD of 2.9”.
- End covers included with all cassette systems.
- Compatible with battery QMotion® Automated shades only.



The Qmotion® Cassette is formed of two extruded parts. The top and back extrusion is a durable structural aluminum, designed to mount securely and retain the Qmotion® system. The face plate is a limited vinyl material engineered to be durable and attractive, while making installation and battery changes simple.





## Fabric Listings

These charts are for **QMotion® Automated and Qfree Manual shades**. They are designed to provide extensive details on the shades that we would produce with our systems.

In the charts, the grey sections are not available. This is fabric related, as some materials cannot be railroaded. The numbers in each cell indicate the diameter of the rolled fabric when raised to the top. Fabric suppliers have variation in their weaves, but this information is based on our expectations from the data for each material.

The section in the white color indicates that the shade will be manufactured on our 2.5” brackets. The section in light blue color will be made on the 3.7” brackets. The dark line, cutting through the graph indicates the size at which we would railroad the fabric, if available.

Fabrics that can't be railroaded, check fabric width for maximum shade width.

At this time, we are only producing shades as large as 144” in either width or height. Additional sizes may be available in the near future.

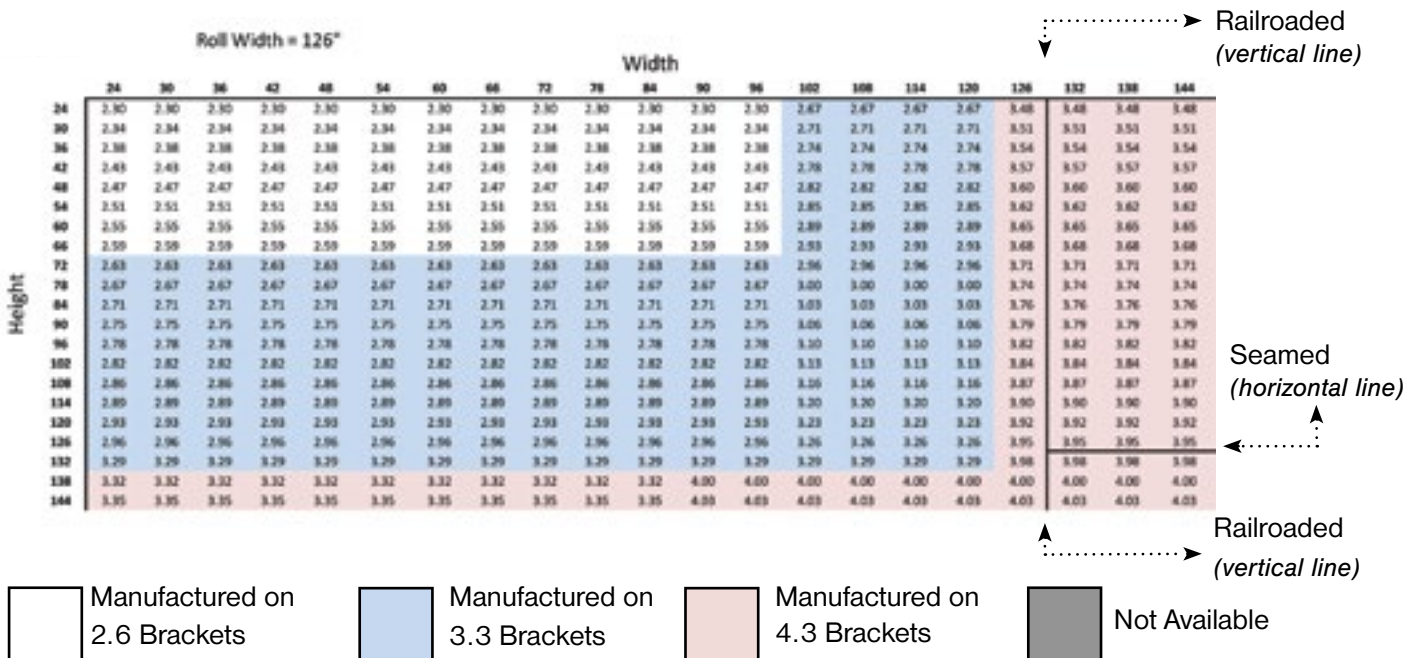

### Fabric Selections (Charts on the following 12 pages):

2701-1%	4400-3%	Bali	E-Screen-5%	Linen	Natural Screen	SW 2500-1%	Chantilly	Metallic
2703-3%	4800-1%	E-Screen-1%	Oasis	M-Screen	Cirrus	Columns	Chantilly Blkt	Vizela
2705-5%	Fiji	E-Screen-10%	Infinity-3%	Island	SW 2390-5%	Tones	Eternity	Flocke
4000-5%	Avila Twilight	E-Screen-3%	Infinity-5%	Matte	SW 2410-3%	Tones Blackout	Eternity Pearl	Edessa









Fiji Roll Width = 110"

		Width																				
		24	30	36	42	48	54	60	66	72	78	84	90	96	102	108	114	120	126	132	138	144
Height	24	2.40	2.40	2.40	2.40	2.40	2.40	2.40	2.40	2.40	2.40	2.40	2.40	2.40	2.76	2.76						
	30	2.46	2.46	2.46	2.46	2.46	2.46	2.46	2.46	2.46	2.46	2.46	2.46	2.46	2.81	2.81						
	36	2.51	2.51	2.51	2.51	2.51	2.51	2.51	2.51	2.51	2.51	2.51	2.51	2.51	2.86	2.86						
	42	2.57	2.57	2.57	2.57	2.57	2.57	2.57	2.57	2.57	2.57	2.57	2.57	2.57	2.91	2.91						
	48	2.62	2.62	2.62	2.62	2.62	2.62	2.62	2.62	2.62	2.62	2.62	2.62	2.62	2.96	2.96						
	54	2.68	2.68	2.68	2.68	2.68	2.68	2.68	2.68	2.68	2.68	2.68	2.68	2.68	3.01	3.01						
	60	2.73	2.73	2.73	2.73	2.73	2.73	2.73	2.73	2.73	2.73	2.73	2.73	2.73	3.05	3.05						
	66	2.78	2.78	2.78	2.78	2.78	2.78	2.78	2.78	2.78	2.78	2.78	2.78	2.78	3.10	3.10						
	72	2.83	2.83	2.83	2.83	2.83	2.83	2.83	2.83	2.83	2.83	2.83	2.83	2.83	3.14	3.14						
	78	2.88	2.88	2.88	2.88	2.88	2.88	2.88	2.88	2.88	2.88	2.88	2.88	2.88	3.19	3.19						
	84	2.93	2.93	2.93	2.93	2.93	2.93	2.93	2.93	2.93	2.93	2.93	2.93	2.93	3.23	3.23						
	90	2.98	2.98	2.98	2.98	2.98	2.98	2.98	2.98	2.98	2.98	2.98	2.98	2.98	3.28	3.28						
	96	3.02	3.02	3.02	3.02	3.02	3.02	3.02	3.02	3.02	3.02	3.02	3.02	3.02	3.32	3.32						
	102	3.07	3.07	3.07	3.07	3.07	3.07	3.07	3.07	3.07	3.07	3.07	3.07	3.07	3.36	3.36						
	108	3.11	3.11	3.11	3.11	3.11	3.11	3.11	3.11	3.11	3.11	3.11	3.11	3.11	3.40	3.40						
	114	3.16	3.16	3.16	3.16	3.16	3.16	3.16	3.16	3.16	3.16	3.16	3.16	3.16	3.44	3.44						
120	3.20	3.20	3.20	3.20	3.20	3.20	3.20	3.20	3.20	3.20	3.20	3.20	3.20	3.49	3.49							
126	3.25	3.25	3.25	3.25	3.25	3.25	3.25	3.25	3.25	3.25	3.25	3.25	3.25	3.53	3.53							
132	3.29	3.29	3.29	3.29	3.29	3.29	3.29	3.29	3.29	3.29	3.29	3.29	3.29	3.57	3.57							
138	3.60	3.60	3.60	3.60	3.60	3.60	3.60	3.60	3.60	3.60	3.60	3.60	3.60	3.60	3.60							
144	3.64	3.64	3.64	3.64	3.64	3.64	3.64	3.64	3.64	3.64	3.64	3.64	3.64	3.64	3.64							

Avila Twilight Roll Width = 110"

		Width																				
		24	30	36	42	48	54	60	66	72	78	84	90	96	102	108	114	120	126	132	138	144
Height	24	2.22	2.22	2.22	2.22	2.22	2.22	2.22	2.22	2.22	2.22	2.22	2.22	2.22	2.60	2.60						
	30	2.26	2.26	2.26	2.26	2.26	2.26	2.26	2.26	2.26	2.26	2.26	2.26	2.26	2.63	2.63						
	36	2.29	2.29	2.29	2.29	2.29	2.29	2.29	2.29	2.29	2.29	2.29	2.29	2.29	2.66	2.66						
	42	2.32	2.32	2.32	2.32	2.32	2.32	2.32	2.32	2.32	2.32	2.32	2.32	2.32	2.69	2.69						
	48	2.36	2.36	2.36	2.36	2.36	2.36	2.36	2.36	2.36	2.36	2.36	2.36	2.36	2.72	2.72						
	54	2.39	2.39	2.39	2.39	2.39	2.39	2.39	2.39	2.39	2.39	2.39	2.39	2.39	2.74	2.74						
	60	2.42	2.42	2.42	2.42	2.42	2.42	2.42	2.42	2.42	2.42	2.42	2.42	2.42	2.77	2.77						
	66	2.45	2.45	2.45	2.45	2.45	2.45	2.45	2.45	2.45	2.45	2.45	2.45	2.45	2.80	2.80						
	72	2.48	2.48	2.48	2.48	2.48	2.48	2.48	2.48	2.48	2.48	2.48	2.48	2.48	2.83	2.83						
	78	2.51	2.51	2.51	2.51	2.51	2.51	2.51	2.51	2.51	2.51	2.51	2.51	2.51	2.85	2.85						
	84	2.54	2.54	2.54	2.54	2.54	2.54	2.54	2.54	2.54	2.54	2.54	2.54	2.54	2.88	2.88						
	90	2.57	2.57	2.57	2.57	2.57	2.57	2.57	2.57	2.57	2.57	2.57	2.57	2.57	2.91	2.91						
	96	2.60	2.60	2.60	2.60	2.60	2.60	2.60	2.60	2.60	2.60	2.60	2.60	2.60	2.93	2.93						
	102	2.63	2.63	2.63	2.63	2.63	2.63	2.63	2.63	2.63	2.63	2.63	2.63	2.63	2.96	2.96						
	108	2.66	2.66	2.66	2.66	2.66	2.66	2.66	2.66	2.66	2.66	2.66	2.66	2.66	2.98	2.98						
	114	2.69	2.69	2.69	2.69	2.69	2.69	2.69	2.69	2.69	2.69	2.69	2.69	2.69	3.01	3.01						
120	2.72	2.72	2.72	2.72	2.72	2.72	2.72	2.72	2.72	2.72	2.72	2.72	2.72	3.03	3.03							
126	3.06	3.06	3.06	3.06	3.06	3.06	3.06	3.06	3.06	3.06	3.06	3.06	3.06	3.06	3.06							
132	3.08	3.08	3.08	3.08	3.08	3.08	3.08	3.08	3.08	3.08	3.08	3.08	3.08	3.80	3.80	3.80						
138	3.11	3.11	3.11	3.11	3.11	3.11	3.11	3.11	3.11	3.11	3.11	3.11	3.11	3.82	3.82	3.82						
144				3.84	3.84	3.84	3.84	3.84	3.84	3.84	3.84	3.84	3.84	3.84	3.84	3.84						

Ball Roll Width = 110"

		Width																				
		24	30	36	42	48	54	60	66	72	78	84	90	96	102	108	114	120	126	132	138	144
Height	24	2.35	2.35	2.35	2.35	2.35	2.35	2.35	2.35	2.35	2.35	2.35	2.35	2.35	2.71	2.71						
	30	2.40	2.40	2.40	2.40	2.40	2.40	2.40	2.40	2.40	2.40	2.40	2.40	2.40	2.76	2.76						
	36	2.45	2.45	2.45	2.45	2.45	2.45	2.45	2.45	2.45	2.45	2.45	2.45	2.45	2.80	2.80						
	42	2.50	2.50	2.50	2.50	2.50	2.50	2.50	2.50	2.50	2.50	2.50	2.50	2.50	2.85	2.85						
	48	2.55	2.55	2.55	2.55	2.55	2.55	2.55	2.55	2.55	2.55	2.55	2.55	2.55	2.89	2.89						
	54	2.59	2.59	2.59	2.59	2.59	2.59	2.59	2.59	2.59	2.59	2.59	2.59	2.59	2.93	2.93						
	60	2.64	2.64	2.64	2.64	2.64	2.64	2.64	2.64	2.64	2.64	2.64	2.64	2.64	2.97	2.97						
	66	2.69	2.69	2.69	2.69	2.69	2.69	2.69	2.69	2.69	2.69	2.69	2.69	2.69	3.01	3.01						
	72	2.73	2.73	2.73	2.73	2.73	2.73	2.73	2.73	2.73	2.73	2.73	2.73	2.73	3.05	3.05						
	78	2.78	2.78	2.78	2.78	2.78	2.78	2.78	2.78	2.78	2.78	2.78	2.78	2.78	3.09	3.09						
	84	2.82	2.82	2.82	2.82	2.82	2.82	2.82	2.82	2.82	2.82	2.82	2.82	2.82	3.13	3.13						
	90	2.86	2.86	2.86	2.86	2.86	2.86	2.86	2.86	2.86	2.86	2.86	2.86	2.86	3.17	3.17						
	96	2.91	2.91	2.91	2.91	2.91	2.91	2.91	2.91	2.91	2.91	2.91	2.91	2.91	3.21	3.21						
	102	2.95	2.95	2.95	2.95	2.95	2.95	2.95	2.95	2.95	2.95	2.95	2.95	2.95	3.25	3.25						
	108	2.99	2.99	2.99	2.99	2.99	2.99	2.99	2.99	2.99	2.99	2.99	2.99	2.99	3.28	3.28						
	114	3.03	3.03	3.03	3.03	3.03	3.03	3.03	3.03	3.03	3.03	3.03	3.03	3.03	3.32	3.32						
120	3.07	3.07	3.07	3.07	3.07	3.07	3.07	3.07	3.07	3.07	3.07	3.07	3.07	3.36	3.36							
126	3.11	3.11	3.11	3.11	3.11	3.11	3.11	3.11	3.11	3.11	3.11	3.11	3.11	3.39	3.39							
132	3.15	3.15	3.15	3.15	3.15	3.15	3.15	3.15	3.15	3.15	3.15	3.15	3.15	3.43	3.43							
138	3.47	3.47	3.47	3.47	3.47	3.47	3.47	3.47	3.47	3.47	3.47	3.47	3.47	3.47	3.47							
144	3.50	3.50	3.50	3.50	3.50	3.50	3.50	3.50	3.50	3.50	3.50	4.16	4.16	4.16	4.16	4.16						





























Metallic

Roll Width = 78"

Height	Width																				
	24	30	36	42	48	54	60	66	72	78	84	90	96	102	108	114	120	126	132	138	144
24	2.17	2.17	2.17	2.17	2.17	2.17	2.17	2.17	2.17	2.17											
30	2.19	2.19	2.19	2.19	2.19	2.19	2.19	2.19	2.19	2.19											
36	2.22	2.22	2.22	2.22	2.22	2.22	2.22	2.22	2.22	2.22											
42	2.25	2.25	2.25	2.25	2.25	2.25	2.25	2.25	2.25	2.25											
48	2.27	2.27	2.27	2.27	2.27	2.27	2.27	2.27	2.27	2.27											
54	2.30	2.30	2.30	2.30	2.30	2.30	2.30	2.30	2.30	2.30											
60	2.32	2.32	2.32	2.32	2.32	2.32	2.32	2.32	2.32	2.32											
66	2.35	2.35	2.35	2.35	2.35	2.35	2.35	2.35	2.35	2.35											
72	2.37	2.37	2.37	2.37	2.37	2.37	2.37	2.37	2.37	2.37											
78	2.39	2.39	2.39	2.39	2.39	2.39	2.39	2.39	2.39	2.39											
84	2.42	2.42	2.42	2.42	2.42	2.42	2.42	2.42	2.42	2.42											
90	2.44	2.44	2.44	2.44	2.44	2.44	2.44	2.44	2.44	2.44											
96	2.47	2.47	2.47	2.47	2.47	2.47	2.47	2.47	2.47	2.47											
102	2.49	2.49	2.49	2.49	2.49	2.49	2.49	2.49	2.49	2.49											
108	2.51	2.51	2.51	2.51	2.51	2.51	2.51	2.51	2.51	2.51											
114	2.53	2.53	2.53	2.53	2.53	2.53	2.53	2.53	2.53	2.53											
120	2.89	2.89	2.89	2.89	2.89	2.89	2.89	2.89	2.89	2.89											
126	2.91	2.91	2.91	2.91	2.91	2.91	2.91	2.91	2.91	2.91											
132	2.93	2.93	2.93	2.93	2.93	2.93	2.93	2.93	2.93	2.93											
138				3.69	3.69	3.69	3.69	3.69	3.69	3.69											
144				3.70	3.70	3.70	3.70	3.70	3.70	3.70											

Vizela

Roll Width = 78"

Height	Width																				
	24	30	36	42	48	54	60	66	72	78	84	90	96	102	108	114	120	126	132	138	144
24	2.15	2.15	2.15	2.15	2.15	2.15	2.15	2.15	2.15	2.15	2.15	2.15	2.15	2.53	2.53	2.53	2.53	3.36	3.36	3.36	3.36
30	2.17	2.17	2.17	2.17	2.17	2.17	2.17	2.17	2.17	2.17	2.17	2.17	2.17	2.55	2.55	2.55	2.55	3.38	3.38	3.38	3.38
36	2.19	2.19	2.19	2.19	2.19	2.19	2.19	2.19	2.19	2.19	2.19	2.19	2.19	2.57	2.57	2.57	2.57	3.39	3.39	3.39	3.39
42	2.21	2.21	2.21	2.21	2.21	2.21	2.21	2.21	2.21	2.21	2.21	2.21	2.21	2.59	2.59	2.59	2.59	3.41	3.41	3.41	3.41
48	2.24	2.24	2.24	2.24	2.24	2.24	2.24	2.24	2.24	2.24	2.24	2.24	2.24	2.61	2.61	2.61	2.61	3.42	3.42	3.42	3.42
54	2.26	2.26	2.26	2.26	2.26	2.26	2.26	2.26	2.26	2.26	2.26	2.26	2.26	2.63	2.63	2.63	2.63	3.43	3.43	3.43	3.43
60	2.28	2.28	2.28	2.28	2.28	2.28	2.28	2.28	2.28	2.28	2.28	2.28	2.28	2.65	2.65	2.65	2.65	3.45	3.45	3.45	3.45
66	2.30	2.30	2.30	2.30	2.30	2.30	2.30	2.30	2.30	2.30	2.30	2.30	2.30	2.67	2.67	2.67	2.67	3.46	3.46	3.46	3.46
72	2.32	2.32	2.32	2.32	2.32	2.32	2.32	2.32	2.32	2.32	2.32	2.32	2.32	2.68	2.68	2.68	2.68	3.48	3.48	3.48	3.48
78	2.35	2.35	2.35	2.35	2.35	2.35	2.35	2.35	2.35	2.35	2.35	2.35	2.35	2.70	2.70	2.70	2.70	3.49	3.49	3.49	3.49
84	2.37	2.37	2.37	2.37	2.37	2.37	2.37	2.37	2.37	2.37	2.37	2.37	2.37	2.72	2.72	2.72	2.72	3.51	3.51	3.51	3.51
90	2.39	2.39	2.39	2.39	2.39	2.39	2.39	2.39	2.39	2.39	2.39	2.39	2.39	2.74	2.74	2.74	2.74	3.52	3.52	3.52	3.52
96	2.41	2.41	2.41	2.41	2.41	2.41	2.41	2.41	2.41	2.41	2.41	2.41	2.41	2.76	2.76	2.76	2.76	3.53	3.53	3.53	3.53
102	2.43	2.43	2.43	2.43	2.43	2.43	2.43	2.43	2.43	2.43	2.43	2.43	2.43	2.77	2.77	2.77	2.77	3.55	3.55	3.55	3.55
108	2.45	2.45	2.45	2.45	2.45	2.45	2.45	2.45	2.45	2.45	2.45	2.45	2.45	2.79	2.79	2.79	2.79	3.56	3.56	3.56	3.56
114	2.81	2.81	2.81	2.81	2.81	2.81	2.81	2.81	2.81	2.81	2.81	2.81	2.81	2.81	2.81	2.81	2.81	3.58	3.58	3.58	3.58
120	2.83	2.83	2.83	2.83	2.83	2.83	2.83	2.83	2.83	2.83	2.83	2.83	2.83	2.83	2.83	2.83	2.83	3.59	3.59	3.59	3.59
126	2.85	2.85	2.85	2.85	2.85	2.85	2.85	2.85	2.85	2.85	2.85	2.85	2.85	2.85	2.85	2.85	2.85	3.60	3.60	3.60	3.60
132	2.86	2.86	2.86	2.86	2.86	2.86	2.86	2.86	2.86	2.86	2.86	2.86	2.86	2.86	2.86	2.86	2.86	3.62	3.62	3.62	3.62
138				3.63	3.63	3.63	3.63	3.63	3.63	3.63								3.63	3.63	3.63	3.63
144				3.65	3.65	3.65	3.65	3.65	3.65	3.65								3.65	3.65	3.65	3.65

Flocke'

Roll Width = 78"

Height	Width																				
	24	30	36	42	48	54	60	66	72	78	84	90	96	102	108	114	120	126	132	138	144
24	2.23	2.23	2.23	2.23	2.23	2.23	2.23	2.23	2.23	2.23	2.23	2.23	2.23	2.61	2.61	2.61	2.61	3.43	3.43	3.43	3.43
30	2.27	2.27	2.27	2.27	2.27	2.27	2.27	2.27	2.27	2.27	2.27	2.27	2.27	2.64	2.64	2.64	2.64	3.45	3.45	3.45	3.45
36	2.30	2.30	2.30	2.30	2.30	2.30	2.30	2.30	2.30	2.30	2.30	2.30	2.30	2.67	2.67	2.67	2.67	3.48	3.48	3.48	3.48
42	2.34	2.34	2.34	2.34	2.34	2.34	2.34	2.34	2.34	2.34	2.34	2.34	2.34	2.70	2.70	2.70	2.70	3.50	3.50	3.50	3.50
48	2.37	2.37	2.37	2.37	2.37	2.37	2.37	2.37	2.37	2.37	2.37	2.37	2.37	2.73	2.73	2.73	2.73	3.52	3.52	3.52	3.52
54	2.41	2.41	2.41	2.41	2.41	2.41	2.41	2.41	2.41	2.41	2.41	2.41	2.41	2.76	2.76	2.76	2.76	3.54	3.54	3.54	3.54
60	2.44	2.44	2.44	2.44	2.44	2.44	2.44	2.44	2.44	2.44	2.44	2.44	2.44	2.79	2.79	2.79	2.79	3.57	3.57	3.57	3.57
66	2.47	2.47	2.47	2.47	2.47	2.47	2.47	2.47	2.47	2.47	2.47	2.47	2.47	2.82	2.82	2.82	2.82	3.59	3.59	3.59	3.59
72	2.50	2.50	2.50	2.50	2.50	2.50	2.50	2.50	2.50	2.50	2.50	2.50	2.50	2.85	2.85	2.85	2.85	3.61	3.61	3.61	3.61
78	2.54	2.54	2.54	2.54	2.54	2.54	2.54	2.54	2.54	2.54	2.54	2.54	2.54	2.87	2.87	2.87	2.87	3.63	3.63	3.63	3.63
84	2.57	2.57	2.57	2.57	2.57	2.57	2.57	2.57	2.57	2.57	2.57	2.57	2.57	2.90	2.90	2.90	2.90	3.66	3.66	3.66	3.66
90	2.60	2.60	2.60	2.60	2.60	2.60	2.60	2.60	2.60	2.60	2.60	2.60	2.60	2.93	2.93	2.93	2.93	3.68	3.68	3.68	3.68
96	2.63	2.63	2.63	2.63	2.63	2.63	2.63	2.63	2.63	2.63	2.63	2.63	2.63	2.96	2.96	2.96	2.96	3.70	3.70	3.70	3.70
102	2.66	2.66	2.66	2.66	2.66	2.66	2.66	2.66	2.66	2.66	2.66	2.66	2.66	2.98	2.98	2.98	2.98	3.72	3.72	3.72	3.72
108	2.69	2.69	2.69	2.69	2.69	2.69	2.69	2.69	2.69	2.69	2.69	2.69	2.69	3.01	3.01	3.01	3.01	3.74	3.74	3.74	3.74
114	2.72	2.72	2.72	2.72	2.72	2.72	2.72	2.72	2.72	2.72	2.72	2.72	2.72	3.04	3.04	3.04	3.04	3.76	3.76	3.76	3.76
120	2.75	2.75	2.75	2.75	2.75	2.75	2.75	2.75	2.75	2.75	2.75	2.75	2.75	3.06	3.06	3.06	3.06	3.78	3.78	3.78	3.78
126	3.09	3.09	3.09	3.09	3.09	3.09	3.09	3.09	3.09	3.09	3.09	3.09	3.09	3.09	3.09	3.09	3.09	3.81	3.81	3.81	3.81
132	3.11	3.11	3.11	3.11	3.11	3.11	3.11	3.11	3.11	3.11	3.11	3.11	3.11	3.11	3.11	3.11	3.11	3.83	3.83	3.83	3.83
138	3.14	3.14	3.14	3.14	3.14	3.14	3.14	3.14	3.14	3.14	3.14	3.14	3.14	3.14	3.14	3.14	3.14	3.85	3.85	3.85	3.85
144				3.87	3.87	3.87	3.87	3.87	3.87	3.87								3.87	3.87	3.87	3.87



# QMotion® Color Listings

Collection	Color Name	Color #	Standard Color for endcaps, hembars & fascia	Collection	Color Name	Color #	Standard Color for endcaps, hembars & fascia
				Bali	Marsh	80G0135	Bronze
SW 2701 1%	Oyster/Beige	80P0246	Sand	Bali	Mocha	80G0136	Bronze
SW 2701 1%	Oyster Pewter	80P0064	Silver	E-Screen 1%	White/White	80M0053	White
SW 2701 1%	Oyster Chestnut	80P0065	Bronze	E-Screen 1%	White/Linen	80M0054	White
SW 2701 1%	Oyster Charcoal	80P0066	Black	E-Screen 1%	Charcoal/Bronze	80M0055	Bronze
SW 2703 3%	Oyster/Beige	80P0247	Sand	E-Screen 1%	Charcoal/Charcoal	80M0056	White
SW 2703 3%	Oyster Pewter	80P0068	Silver	E-Screen 1%	Linen/Linen	80M0129	Silver
SW 2703 3%	Oyster Chestnut	80P0069	Bronze	E-Screen 10%	White/White	80M0007	White
SW 2703 3%	Oyster Charcoal	80P0070	Black	E-Screen 10%	White/Linen	80M0008	White
SW 2705 5%	Oyster/Beige	80P0248	Sand	E-Screen 10%	Charcoal/Bronze	80M0009	Bronze
SW 2705 5%	Oyster Pewter	80P0072	Silver	E-Screen 10%	Charcoal/Charcoal	80M0010	Black
SW 2705 5%	Oyster Chestnut	80P0073	Bronze	E-Screen 10%	Pearl/Linen	80M0011	Silver
SW 2705 5%	Oyster Charcoal	80P0074	Black	E-Screen 10%	Linen/Linen	80M0130	Silver
SW 4000 5%	Chalk	80P0075	White	E-Screen 3%	White/White	80M0058	White
SW 4000 5%	Alabaster	80P0076	White	E-Screen 3%	White/Linen	80M0059	White
SW 4000 5%	Pebblestone	80P0077	Sand	E-Screen 3%	Charcoal/Bronze	80M0060	Bronze
SW 4000 5%	Greystone	80P0078	Silver	E-Screen 3%	Charcoal/Charcoal	80M0061	Black
SW 4000 5%	Pewter	80P0079	Silver	E-Screen 3%	Linen/Linen	80M0131	Silver
SW 4000 5%	Tobacco	80P0080	Bronze	E-Screen 5%	White/White	80M0002	White
SW 4000 5%	Ebony	80P0081	Black	E-Screen 5%	White/Linen	80M0003	White
SW 4400 3%	Chalk	80P0082	White	E-Screen 5%	Charcoal/Bronze	80M0004	Bronze
SW 4400 3%	Alabaster	80P0083	White	E-Screen 5%	Charcoal/Charcoal	80M0005	Black
SW 4400 3%	Pebblestone	80P0084	Sand	E-Screen 5%	Linen/Linen	80M0132	Silver
SW 4400 3%	Greystone	80P0085	Silver	Oasis	Gold	80G0137	Sand
SW 4400 3%	Pewter	80P0086	Silver	Oasis	Bronze	80G0138	Bronze
SW 4400 3%	Tobacco	80P0087	Bronze	Oasis	Platinum	80G0139	Black
SW 4400 3%	Ebony	80P0088	Black	Infiniti 3%	PG2 Almond	80P0095	Sand
SW 4800 1%	Chalk	80P0089	White	Infiniti 3%	PG 4 Stone	80 P0249	Silver
SW 4800 1%	Alabaster	80P0090	White	Infiniti 3%	PG1 Cotton	80P0096	White
SW 4800 1%	Taupe	80G0242	Sand	Infiniti 3%	VG4 Slate	80P0250	Silver
SW 4800 1%	Grey	80G0243	Silver	Infiniti 3%	QG1 Barley	80P0098	Sand
SW 4800 1%	Clay	80M0244	Silver	Infiniti 3%	VG1 Nickel	80P0099	Silver
SW 4800 1%	Pearl	80P0091	White	Infiniti 5%	PG2 Almond	80P0101	Sand
SW 4800 1%	Sand	80P0091	Sand	Infiniti 5%	PG1 Cotton	80P0102	White
Fiji	Latte	80G0133	Bronze	Infiniti 5%	VG2 Midnight	80P0103	Black
Fiji	Mocha	80G0134	Bronze	Infiniti 5%	PG4 Stone	80P0251	Silver
Avila Twilight	Pearl	80M0037	White	Infiniti 5%	QG1 Barley	80P0104	Sand
Avila Twilight	White	80M0038	White	Infiniti 5%	VG3 Bark	80P0106	Bronze
Avila Twilight	Linen	80M0039	Sand	Linen	White	80G0140	White
Avila Twilight	Chocolate	80M0040	Bronze	Linen	Ivory	80G0141	Sand
Avila Twilight	Slate Grey	80M0041	Silver	Linen	Beige	80G0142	Sand
Avila Twilight	Black	80M0128	Black	Linen	Mushroom	80G0143	Bronze



# QMotion® Color Listings

Collection	Color Name	Color #	Standard Color for endcaps, hembars & fascia	Collection	Color Name	Color #	Standard Color for endcaps, hembars & fascia
Linen	Toffee	80G0144	Bronze	SW 2500 1%	Charcoal/Grey	80P0241	Silver
Linen	Mocha	80G0145	Bronze	SW 2500 1%	Charcoal	80P0126	Silver
M-Screen	White	80M0018	White	SW 2500 1%	Charcoal Chestnut	80P0127	Bronze
M-Screen	White Stone	80M0020	White	Columns	White	80G0157	White
M-Screen	Charcoal/Apricot	80M0017	Bronze	Columns	Ivory	80G0158	Sand
M-Screen	Charcoal/Sable	80M0019	Bronze	Columns	Brown	80G0159	Bronze
M-Screen	Cocoa/Charcoal	80M0021	Bronze	Tones	Red	80J0172	White
Island	Mushroom	80G0146	Sand	Tones	Carnation	80J0169	White
Island	Cherry	80G0147	Sand	Tones	Rose	80J0170	White
Island	Brown	80G0148	Bronze	Tones	Cherry	80J0171	Sand
Island	Chocolate	80G0149	Bronze	Tones	Toffee	80J0173	Bronze
Matte	White	80B0160	White	Tones	Brown	80J0174	Bronze
Matte	Linen	80B0161	Sand	Tones	Aqua	80J0175	Silver
Matte	Fawn	80B0162	Sand	Tones	Teal	80J0176	White
Matte	Stone Duplex	80B0163	Silver	Tones	Sea Foam	80J0177	White
Matte	Black/White	80B0164	Black	Tones	Black	80J0178	Black
Nature Screen	Black	80G0150	Black	Tones	Gray	80J0179	Silver
Nature Screen	Grey	80G0151	Silver	Tones	Light Gray	80J0180	Silver
Nature Screen	White	80G0152	White	Tones	Alabaster	80J0181	Silver
Nature Screen	Ivory	80G0153	White	Tones	Violet	80J0182	White
Cirrus	White	80G0154	White	Tones	Majesty	80J0183	White
Cirrus	Ivory	80G0155	White	Tones	Navy	80J0184	Silver
Cirrus	Golden	80G0156	Sand	Tones	Royal Blue	80J0185	White
SW 2390 5%	Oyster	80P0107	White	Tones	Atlantic	80J0186	White
SW 2390 5%	Oyster Beige	80P0108	Sand	Tones	Sky Blue	80J0187	White
SW 2390 5%	Oyster Pearl Grey	80P0238	Silver	Tones	Powder	80J0188	White
SW 2390 5%	Beige Pearl Grey	80P0110	Sand	Tones	Turquoise	80J0189	White
SW 2390 5%	Charcoal Grey	80P0239	Silver	Tones	Otter	80J0190	Sand
SW 2390 5%	Charcoal	80P0112	Silver	Tones	Sand	80J0191	Sand
SW 2390 5%	Charcoal Chestnut	80P0113	Bronze	Tones	Wheat	80J0192	Sand
SW 2410 3%	Oyster	80P0114	White	Tones	Desert	80J0193	Sand
SW 2410 3%	Oyster Beige	80P0115	Sand	Tones	Cream	80J0194	Sand
SW 2410 3%	Beige	80P0116	Sand	Tones	Blizzard	80J0195	White
SW 2410 3%	Charcoal Grey	80P0237	Silver	Tones Blackout	Light Gray	80J0201	Silver
SW 2410 3%	Oyster/Pearl Grey	80P0236	Silver	Tones Blackout	Desert	80J0207	Sand
SW 2410 3%	Beige Pearl Grey	80P0117	Sand	Chantilly	White	80J0209	White
SW 2410 3%	Charcoal Chestnut	80P0120	Bronze	Chantilly	Gray	80J0210	Silver
SW 2500 1%	Oyster	80P0121	White	Chantilly	Silver	80J0211	Silver
SW 2500 1%	Oyster/Pearl Grey	80P0240	Silver	Chantilly	Cream	80J0212	Sand
SW 2500 1%	Oyster Beige	80P0122	Sand	Chantilly	Khaki	80J0213	Sand
SW 2500 1%	Beige Pearl Grey	80P0124	Sand	Chantilly	Toffee	80J0214	Bronze





# QMotion® Color Listings

Collection	Color Name	Color #	Standard Color for endcaps, hembars & fascia	Collection	Color Name	Color #	Standard Color for endcaps, hembars & fascia
Chantilly	Brown	80J0215	Bronze	Vizela	Mississippi	80M0030	Sand
Chantilly	Black	80J0216	Black	Vizela	Sahel	80M0031	Sand
Chantilly Blackout	White	80J0217	White	Flocke	Sahel	80M0042	Sand
Chantilly Blackout	Khaki	80J0219	Sand	Flocke	Blanc	80M0043	White
Chantilly Blackout	Black	80J0220	Black	Flocke	Mississippi	80M0044	Sand
Eternity	Silver	80J0221	Silver	Flocke	Loutre	80M0045	Silver
Eternity	Gold	80J0222	Black	Flocke	Chartreux	80M0046	Silver
Eternity	Bronze	80J0223	Bronze	Edessa	Reef	80M0252	Sand
Eternity Pearl	Pearl Platinum	80J0224	Black	Edessa	Glacier	80M0253	White
Eternity Pearl	Pearl Silver	80J0225	Sand	Edessa	Beach	80M0254	Sand
Metallic	Silver	80J0226	Silver	Edessa	Savannah	80M0255	Sand
Metallic	Gold	80J0227	Bronze	Edessa	Arctic	80M0256	White
Vizela	Blanc	80M0027	White	Edessa	Desert	80M0257	Sand
Vizela	Chartreux	80M0028	Silver	Edessa	Tundra	80M0258	Bronze
Vizela	Loutre	80M0029	Silver	Edessa	Mesa	80M0259	Bronze



## Accessories

### Finishing touches for a beautiful QMotion experience.

#### Fascia

- Fascia is available in any of the 5 standard colors or fabric wrapped. (White, Silver, Sand, Bronze, Black)
- Fabric wrapped option covers front face and bottom face of fascia.
- All fascia includes light sealing wool pile to further assist in light blocking on the top of the shade.
- All fabric wrapped fascia ship with the same fabric and fabric color as the shade, unless otherwise requested.
- Shipping charges for fascia are included with the shade if ordered with the shade, unless there are excess size charges from the freight carrier.
- Fascia not ordered to fit individual shades will be charged additional shipping charges.

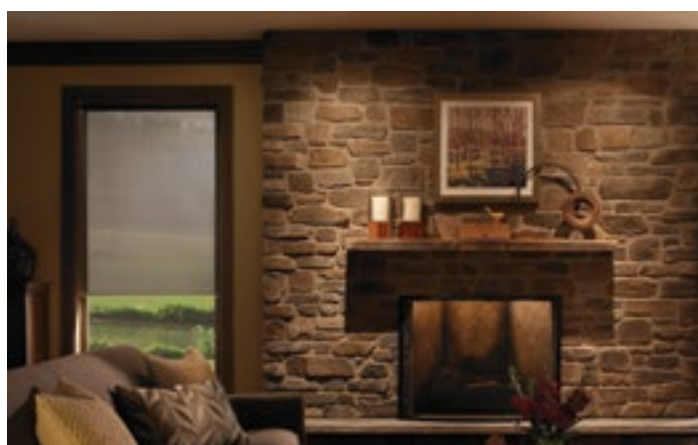

- To ensure proper fit and function, inside mount fascia are cut  $\frac{1}{16}$ " less than the top window width. Outside mount fascia are cut  $\frac{1}{4}$ " larger than the bracket to bracket dimensions.
- For applications when fascia depth does not meet the minimum depth requirements, please contact your customer care representative for fit and finish options.



#### Fascia endcap options

- Fascia endcaps provide a clean look to the sides of the fascia on outside mounts or when the fascia extends out from the window frame on inside mounts.
- Endcaps are color coordinated with fascia.
- All fascia orders include endcaps.
- For inside mount applications, if fascia extends beyond opening, endcaps may be cut in the field for custom fit.
- For inside mount applications, where window opening depth exceeds shade and fascia depth, no endcaps are needed.
- Endcaps extend  $\frac{1}{16}$ " beyond fascia.



## QMotion® Controls

### QMotion® Single Channel 5 Button Remote

- 5 buttons to support up, down, 25%, 50%, 75%
- Magnetic back for simple storing to wall plates
- Controls unlimited number of shades in a group
- Normal remote range: 30 feet

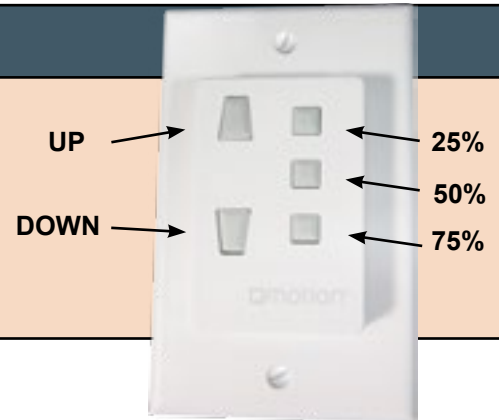

### QMotion® Programmable Timer Remote

- Programmed automated settings in addition to the single channel 5 button remote controls
- Low transmission power, must locate close to shades or Qrelay
- Supports as many as 6 events
- Windows PC programmable
- Time of day, days of week, sunrise/sunset settings
- Normal remote range: 10 feet



### QMotion® Multichannel Remote

- Up to 6 individual or group settings
- All shades programmed to a multichannel remote are controlled together with an "ALL" button on same remote
- Supports up, down, 25%, 50%, 75% actions
- LED light feedback
- Motion activated zone indicated when remote is moved
- Normal remote range: 30 feet







## QMotion® Qconnect

**The Qconnect Interface is a bridge between our language and most building or home automation systems. With drivers for many popular systems, and easy programming tools, clients can easily drive QMotion® Automated shades with their new or existing control systems.**

- RS-232 serial
- RS-485 serial
- Dry contact interface
- 15 channel
- 9v DC power supply or power over CAT 5
- Desk or wall mountable
- 4,000 foot wiring range
- Normal remote range: 50 feet

**Qconnect is compatible with:**



## QMotion® Qrelay

**Each installation is different, and environmental factors may have an effect on transmission. In some cases, a Qrelay may be helpful in improving signal reception. To consider in advance, if a room is over 12'x12', or a shade is 30' from where it would be controlled, the Qrelay is recommended. As these dimensions increase, the Qrelay will become increasingly helpful, and spaces significantly larger may even benefit from more than one Qrelay.**

- Extends range of all QMotion remotes.
- Use as many as required in an installation (no limits)
- Powered from a wall outlet or from a powered USB port
- Two modes of operation "Zone Specific" and "Echo"
  - Zone specific mode allows individual remotes to be learned to the repeater
  - Echo mode repeats all valid Qmotion remote commands
- Normal remote range: 30 feet





## QMotion® Qsync

### **QMotion® Smartphone Application “App” Features:**

- Control Qmotion shades with iOS devices  
-Android mobile devices coming soon
- Virtual Shade: Drag your finger to place the shade to the desired positions
- Connects automatically to Wifi\* and Bridge. “Plug and Play”
- Channel System to name, take and set reference photo to group shades.
- Step by Step setup for learning, setting lower limit, and deleting shades
- Control nearly 500 shades or groups from each Qsync
- TCP/IP to 433Mhz bridge

*\*(Automatic Wifi Connection not available on iOS)*



## QMotion® Hembar Activation

**QMotion® Shades incorporate patented and unique tug features that allow the shade to open with just a short tug, or be lowered without the remote.**

### **Tug the hembar less than 1”**

- Shade opens to next highest preset position  
(example: shade moves from 75% to 50%)

### **Tug the hembar downward between 1” - 2”**

- Shade moves to full open

### **Tug the hembar MORE than approximately 2”**

- Shade remains at position stopped until pulled or sent up with a remote

### **Two successive tugs MORE than approximately 2”**

- Shade moves to full open

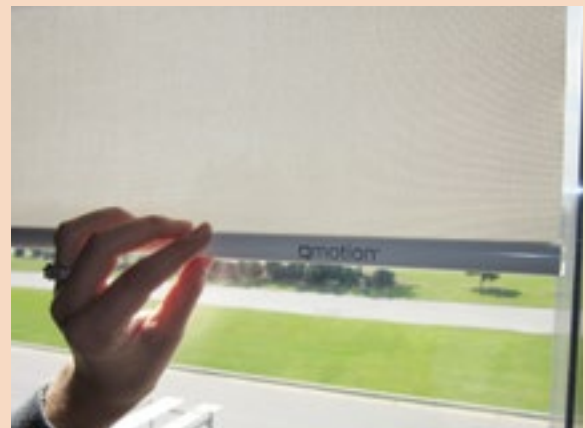



## QMotion® Wall Docking Station

For the convenience of the user, consider QMotion® Wall Docking Stations. Available in Single, Double or Triple gang versions, these wall plates are built to install on a wall as a place to retain the transmitters used in a project. Remote controls hold in place on the Docking Station via a strong magnet, and allow the remote controls to be used as a wall switch for a third level of control for the shades. Wall plates are flush mounted and do not require routing a hole in drywall or other mounting wall finishes. For public spaces, or other places where a remote should be “permanently” attached to a wall, our Wall Station Adaptors mount around the remotes, making them virtually impossible to remove without a screwdriver.



Single Wall Station



Double Wall Station

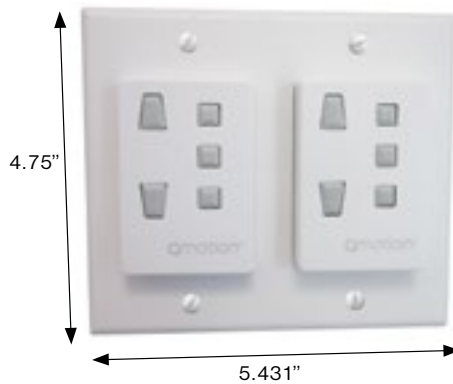

Triple Wall Station

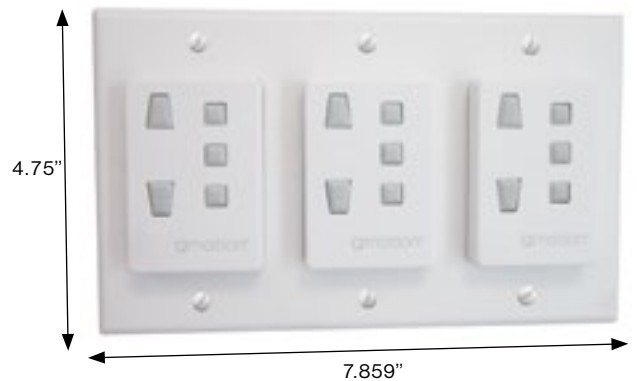

Multichannel-Single

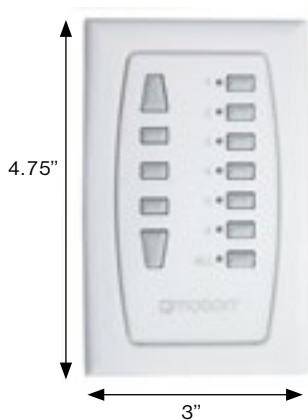

Multichannel-Double

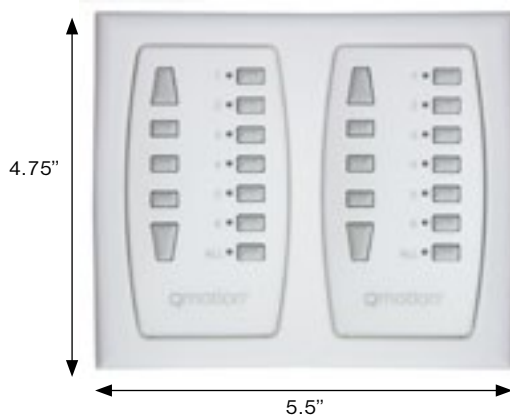

Wall Station Adaptors







## Customer's Own Material (C.O.M.)

In circumstances where the QMotion® Shades fabric assortment is not similar to a desired material, customers may supply the fabric for the shade, and QMotion® will manufacture the shade using this material. Often this is not using roller shade fabric and performance will vary with the type of finish of the fabric. Please verify with your fabric supplier that the fabric can perform properly on a flat roller shade.

For a nominal fee of \$50 (non refundable) a dealer can get a COM material qualified. To qualify COM material, the dealer must supply the following information to a QMotion® Customer Service Representative: 1) Fabric specifications (weight & thickness) and 2) A 1' x 1' sample material shipped to 3400 Copter Rd, Pensacola, FL 32514. Note: Quotes using a COM material are not valid until qualified and approved by QMotion® engineers. QMotion® reserves the right to decline any COM material that does not meet quality specifications All fabric must be shipped to us in ready to use condition, as we will not inspect for quality. Contact our Customer Care Team for material and testing requirements.

## Special Ordered Material (S.O.M.)

In cases where customers desire a material from a supplier of roller shade fabric. This may be colors of our standard styles which are not stocked, or styles from other major suppliers. Please consult with your Qmotion® Customer Care Representative for information about specific fabrics, including pricing and lead times.

*Note that in the case of both C.O.M. and S.O.M., there are extended lead times due to inbound freight and production scheduling.*





## QMotion® Measurement Instructions

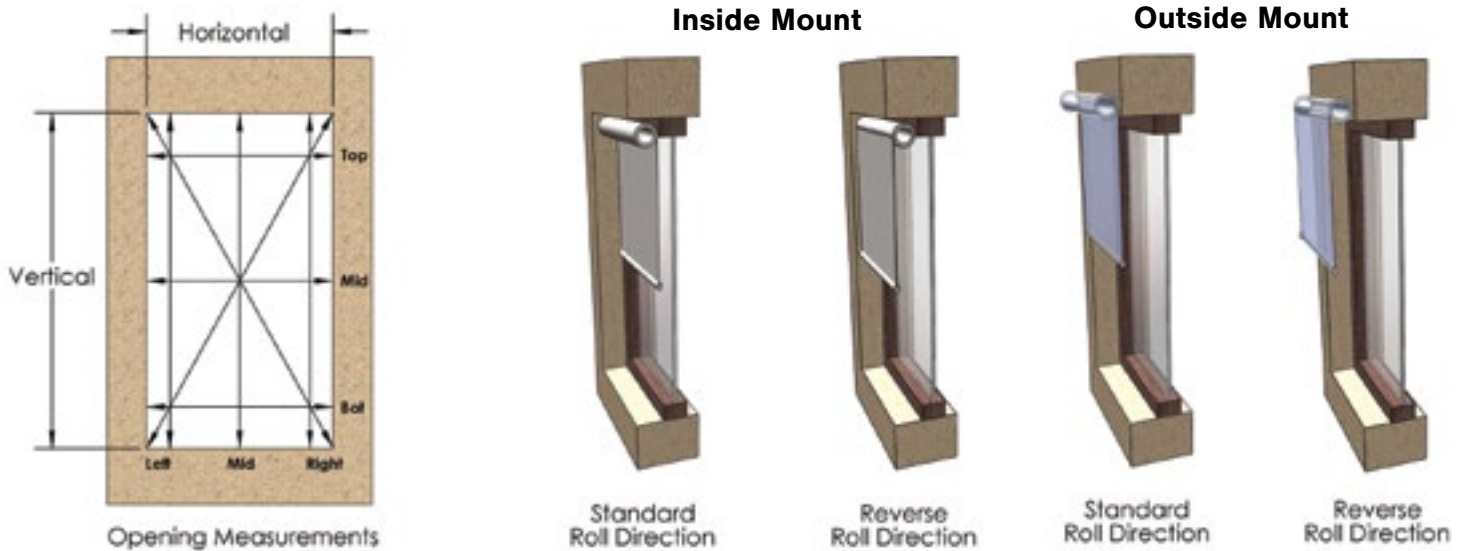

### Measure and assess area to be covered:

- Measure opening to be covered vertically and horizontally in three places.
- If vertical measurements vary more than  $\frac{1}{2}$ " we recommend an outside mount.
- If horizontal measurements vary more than  $\frac{1}{2}$ " we recommend an outside mount.
- Measure and compare diagonals to determine if opening is square.
- If corner to corner diagonal measurements vary more than  $\frac{1}{2}$ " we recommend an outside mount.
- Use a level to determine if opening is plumb and square.
- If out of square or out of plumb by more than  $\frac{1}{2}$ " we recommend an outside mount.

### Measurement rules:

- Make all measurements to the nearest  $\frac{1}{16}$ ". On inside mount applications, round down.
- Measure all windows, even if they appear to be the same size.

### Considerations:

- There must be significant support structure to hold the shade, i.e. wood, concrete, anchored drywall, etc.
- For drywall you may use heavy duty auger style drywall anchors rated sufficient for the weight of the shade.
- Standard roll or reverse roll are available. Reverse roll may be needed to free shade path from obstructions, i.e. handles, locks, alarm sensors, molding, trim, etc.



## QMotion® Measurement Instructions (cont.)

### Required order form measurements for **INSIDE MOUNT:**

- Use the top horizontal measurement for **TOP WIDTH**. This is outside of bracket to outside of bracket.
- Use the largest vertical measurement for **HEIGHT**.
- Measure and record **DEPTH**. Use the minimum distance from the outside of opening to the window including window mullions if they exist. This is important in determining if the shade and fascia will protrude into the room and out of the opening.

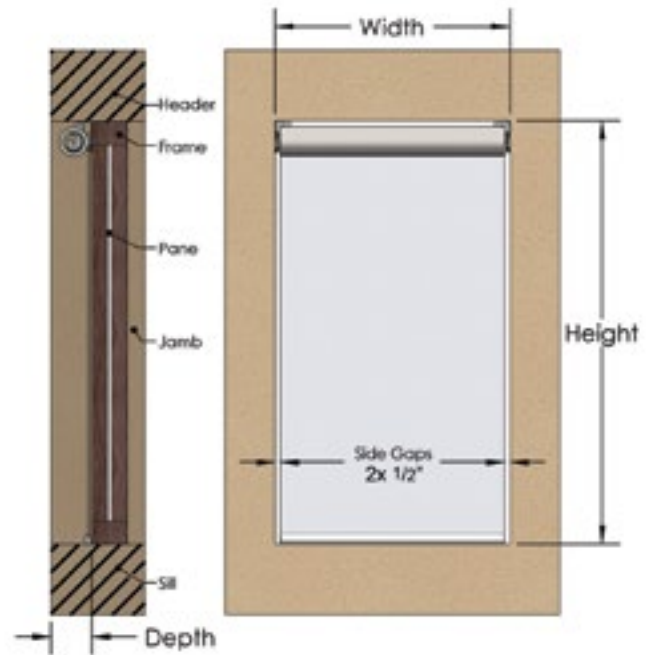

### Required order form measurements for **OUTSIDE MOUNT:**

- Determine **FABRIC WIDTH** based on largest horizontal measurement **PLUS** total desired side overlap.
- Minimum 1.5" side overlap is recommended.
- Establish **WIDTH** dimension by adding 1" to the **FABRIC WIDTH**. This is outside of bracket to outside of bracket. (Note: Brackets extend beyond **FABRIC WIDTH** by 1/2" on each side.)
- Determine **HEIGHT** by adding 3.25" to largest vertical measurement and desired **Sill overlap**. Minimum 1" Sill overlap is recommended.

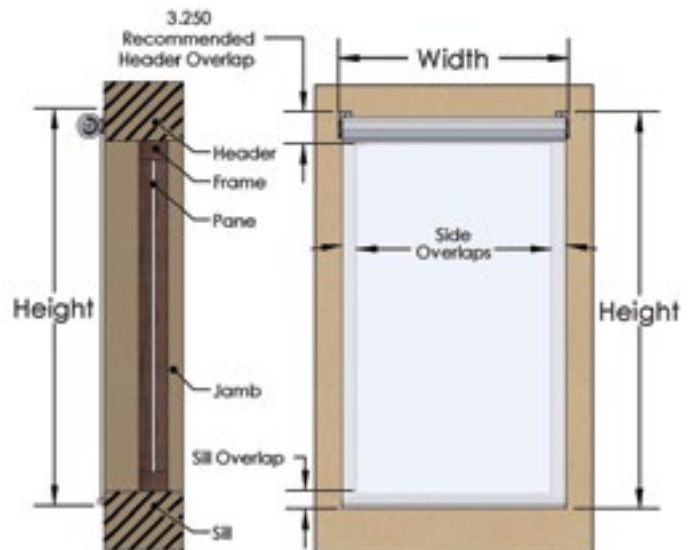





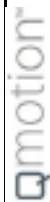

Return to: [Fax] (850) 208-3409 [email] qmotionsales@homerunholdings.com

Job #/Sales Order/Side Mark: \_\_\_\_\_ Date: \_\_\_\_\_

Dealer/ Customer Name: \_\_\_\_\_ Ship To: \_\_\_\_\_ Name: \_\_\_\_\_

Address: \_\_\_\_\_ City: \_\_\_\_\_ State: \_\_\_\_\_ Zip: \_\_\_\_\_

Phone: \_\_\_\_\_ Email: \_\_\_\_\_

Line Item	Quantity	Remote Type	Shade Type <small>(Select one per row)</small>	Window Location	Fabric Number	Fabric Name	Shade Build Specifications				Optional Fascia		
							Hembar Finish <small>Painted (P) Fabric (F)</small>	Mount <small>Inside Exact (I) Outside (O)</small>	Clutch or Low Voltage Wire Side <small>Left (L) Right (R)</small>	Roll Direction <small>Standard (S) Reverse (R)</small>	Width+ <small>(Bracket to Bracket) inches</small>	Height <small>inches</small>	Fascia of Cassette Style <small>Standard (S) Reverse (R) Dual (D)</small>
1		S / M / P					P / F	I / O	L / R	S / R		S / R / D	
2		S / M / P					P / F	I / O	L / R	S / R		S / R / D	
3		S / M / P					P / F	I / O	L / R	S / R		S / R / D	
4		S / M / P					P / F	I / O	L / R	S / R		S / R / D	
5		S / M / P					P / F	I / O	L / R	S / R		S / R / D	
6		S / M / P					P / F	I / O	L / R	S / R		S / R / D	
7		S / M / P					P / F	I / O	L / R	S / R		S / R / D	
8		S / M / P					P / F	I / O	L / R	S / R		S / R / D	
9		S / M / P					P / F	I / O	L / R	S / R		S / R / D	
10		S / M / P					P / F	I / O	L / R	S / R		S / R / D	

\*\*\* Fascia finish - (W) White, (BL) Black, (SI) Silver, (SA) Sand, (BR) Bronze, (FW) Fabric Wrap.  
 -For IB (inside mount) motorized/ independent fascia applications, QMotion will take a 1/16" factory deduction off the bracket to bracket dimension.  
 -For OB (outside mount) motorized/ independent fascia applications, QMotion will add 1/4" to the bracket to bracket dimension  
 -For Exact fascias, please specify the exact width for the fascia in the NOTES column

Shade Types: **Motorized** Qmotion (QM) **Manual** Qfree (QF) **Notes:**

Qmotion Dual (QD) Qbasic (QB)

Qmotion LV (QV)

**Accessories:**

\_\_\_\_\_ # Single Channel Remote \_\_\_\_\_ # Single Channel Double Wallpaper \_\_\_\_\_ # Single Channel Triple Wallpaper \_\_\_\_\_ # Wall Station Adaptor

\_\_\_\_\_ # Multichannel Remote \_\_\_\_\_ # Multichannel Wallpaper \_\_\_\_\_ # Multichannel Double Wallpaper \_\_\_\_\_ # Side Channels \_\_\_\_\_ # Sill Channel

\_\_\_\_\_ # Programmable Timer Remote \_\_\_\_\_ # Qrelay \_\_\_\_\_ # Qconnect \_\_\_\_\_ # Qsync (iPhone)

\_\_\_\_\_ # Single Shade Power Supply \_\_\_\_\_ # Four Shade Power Distribution Box \_\_\_\_\_ # Four Shade Power Supply \_\_\_\_\_ # Sixteen Shade Power Panel

Qlink System Order Form

Return to: [Fax] (855) 268-3469 [email] qmotionstate@homerusholdings.com



Job #/Sales Order/ Side Mark \_\_\_\_\_ Date \_\_\_\_\_

Dealer/ Customer Name \_\_\_\_\_ Ship to: \_\_\_\_\_ Name \_\_\_\_\_

Address \_\_\_\_\_ City \_\_\_\_\_ State \_\_\_\_\_ Zip \_\_\_\_\_

Phone \_\_\_\_\_ Email \_\_\_\_\_

Enter data or circle below. Use only to order a Qlink System.

Qlink System No.		Controller <small>Single (S) Programmable (P) Multi (M)</small>	Window Location	Fabric Number	Fabric Name	Battery or Low Voltage	Mount Style <small>Inside (I) Outside (O)</small>	Roll Direction <small>Standard (S) Reverse (R)</small>	Total Width for Systems* Inches	Height for System Inches	Depth for System** Inches	Fascia Style <small>Standard (S) Recess (R) Dial (D)</small>	Fascia Finish***
___	___	S / P / M				B / LV	I / O	S / R				S / R / D	

The left shade is motorized if standard roll. On reverse roll, the shade on the right is the motorized shade. Let shades starting from the Left, and select either straight or angle for the right side of that shade, except for the last shade on the right.

Shade No.	Shade Panel Width-Bracket to Bracket	Coupler on Right <small>Standard (S) Angle (A)</small>	Shade No.	Shade Panel Width-Bracket to Bracket	Coupler on Right <small>Standard (S) Angle (A)</small>
___1	1st Shade on Left	S / A	___10	10th Shade on Left	S / A
___2	2nd Shade on Left	S / A	___11	11th Shade on Left	S / A
___3	3rd Shade on Left	S / A	___12	12th Shade on Left	S / A
___4	4th Shade on Left	S / A	___13	13th Shade on Left	S / A
___5	5th Shade on Left	S / A	___14	14th Shade on Left	S / A
___6	6th Shade on Left	S / A	___15	15th Shade on Left	S / A
___7	7th Shade on Left	S / A	___16	16th Shade on Left	S / A
___8	8th Shade on Left	S / A	___17	17th Shade on Left	S / A
___9	9th Shade on Left	S / A	___18	18th Shade on Left	S / A

\* For inside mount width use top width measurement. B Shades will have a 1/8" factory deduction.  
 \*\* For outside mount width, use outside bracket to outside bracket width.  
 \*\*\* Depth measurement only needed on inside mount applications.

Notes: \_\_\_\_\_

Accessories:

- \_\_\_ # Single Channel Remotes \_\_\_\_\_ # Dual Wallplates \_\_\_\_\_ # Multi-CH Single Wallplates \_\_\_\_\_ # Multiple shade power supply
- \_\_\_ # Programmable Timer Remotes \_\_\_\_\_ # Triple Wallplates \_\_\_\_\_ # Multi-CH Double Wallplates
- \_\_\_ # Single Wallplates \_\_\_\_\_ # Multi-CH Remotes \_\_\_\_\_ # Inlet Station Adapter
- \_\_\_ # Connect \_\_\_\_\_ # Power supply dist. box \_\_\_\_\_ # Single shade voltage power supply
- \_\_\_ # Only \_\_\_\_\_ # Power supply dist. box

11/20/2012



QMotion® Automated Shades

# Reference Information



## QMotion® Setting Hembar Position

**For shades produced prior to April 14th, 2013.**

### Lowering the Lower Limit

1. **Press and release the DOWN button.**
2. **Shade moves to preprogrammed lower limit.**
3. **Press and hold the DOWN button until the shade jogs, release.**
4. **Tug shade more than 2” to put shade into learn mode.**
5. **Manually pull shade down to lower the lower limit.**
6. **Once desired position is achieved press and hold the DOWN button until the shade begins to travel up then release.**
7. **The shade will travel to the top and now the lower limit is set.**

Note: 25%, 50%, and 75% positions will reset automatically

### Raising The Lower Limit

1. **Press and release the DOWN button.**
2. **Shade moves to preprogrammed lower limit.**
3. **Press and hold the DOWN button until the shade jogs, release.**
4. **Tug shade more than 2” to put shade into learn mode.**
5. **Press and release the UP button, let the shade travel up past previous lower limit, press and release the DOWN button to stop.**
6. **Manually pull to lower limit.**
7. **Once desired position is achieved press and hold the DOWN button until the shade begins to travel up then release.**
8. **The shade will travel to the top and now the lower limit is set.**

Note: 25%, 50%, and 75% positions will be set automatically

### Custom Intermediate Positions

#### **To Set Custom Intermediate Positions HIGHER or LOWER Than Factory Preprogrammed Positions**

1. **Send shade to intermediate position that you wish to change.**
2. **Press and hold that INTERMEDIATE button until the shade jogs, release.**
3. **Tug shade more than 2” to put into learn mode.**
4. **Move the shade to the custom position by manually tugging or using the up button.**
5. **Once desired position is achieved press and hold the INTERMEDIATE button until the shade begins to travel up then release.**
6. **The shade will travel to the top and now the custom intermediate position is set.**



## QMotion® Setting Hembar Position

**For shades produced on or after April 15th, 2013.**

### Setting Any Position Location

**Qmotion shades produced after April 15, 2013 have the additional ability to program the upper stop position. These instructions may be followed the same for each button programming operation, substituting the desired button to be programmed during this process.**

- 1. Send the shade to the position to be changed.**
- 2. Press & Hold the button desired to be changed after the shade has stopped (ex. if the position to be programmed is the upper limit, press and hold the UP button)**
- 3. After about 5 seconds the shade will Jog down 3 inches and back up.**
  - a. Release the position button to be changed.**
  - b. Tug the shade 6 inches to enter learn mode for the button position.**
  - c. Move the shade to the new position by hand or press the UP button 3 times to send the shade to the TOP, then pull down to the desired position.**
  - d. Press and Hold the position button to be set until the shade begins to move UP.**
  - e. The shade will travel to the “hard stop”, the new position has been set.**





## QMotion® Remote Settings

**For shades produced prior to April 14th, 2013.**

### Adding an Additional Remote

1. Move the shade to full open.
2. Press and hold the UP button on a learned remote until the shade begins to move, release.
3. Shade will move to the 75% position.
4. Tug the shade more than 2" to put into learn mode.
5. Press and hold UP button on the new remote until the shade begins to travel up.
6. New remote is learned.

### Deleting A Remote

1. Move the shade to full open.
2. Press and hold the UP button on a learned remote until the shade begins to move, release.
3. Shade will move to the 75% position.
4. Tug the shade more than 2 inches to put into learn mode.
5. Press and hold DOWN button on the remote or channel to be deleted until the shade begins to travel up.
6. Remote or channel is deleted.

### Full Master Reset Procedure

**This procedure clears all original learned remote AND all hembar settings**

1. Move the shade to full open.
2. Press and hold the up button on a learned remote until the shade starts moving, do not release until shade reaches the 75% position and reverses, then release.
3. Shade will stop about 12 inches from the top.
4. Immediately tug shade more than 2 inches to delete all learned remotes and limits.
5. Shade will now be in learn mode for 60 seconds.
6. Learn a new remote by pressing and holding UP button on the remote until the shade begins to move up. Lower limit will now be set to factory default 12 inches.



## QMotion® Remote Settings

**For shades produced on or after April 15th, 2013.**

### Adding or Deleting a Remote

- 1. Send the shade to Top/Upper limit.**
- 2. Press & Hold the UP button after the shade has stopped.**
- 3. After about 5 seconds the shade will jog down 3 inches and back up. Keep holding the UP button, do not release.**
- 4. After about 10 seconds the shade will start traveling to the 75% position**
  - a. Release the Up button.**
  - b. After the shade stops at 75%, tug the shade 6 inches. The shade is now in learn mode.**
    - i. To Add a remote Press and Hold the UP button on the desired new remote or channel until the shade begins to move Up.**
    - ii. To Delete a remote Press and Hold the DOWN button on the desired remote or channel to be deleted until the shade begins to move Up.**
  - c. New remote or channel is added or deleted.**



# QMotion® Remote Settings

**For shades produced on or after April 15th, 2013.**

## Factory Reset Then Adding a Remote

1. **Send the shade to Top/Upper limit.**
2. **Press & Hold the UP button after the shade has stopped.**
3. **After about 5 seconds the shade will Jog down 3 inches and back up. Keep holding the UP button, do not release.**
4. **After about 10 seconds the shade will start traveling to the 75% position. Keep holding the UP button, do not release.**
5. **After about 15 seconds the shade will begin to travel to the Default Shade Length. (About 20 inches). Release the UP button.**
  - a. **When the shade stops it will be ready to perform a Factory Reset.**
  - b. **Tug the shade more than 6 inches within 10 seconds of the shade stopping to perform a Factory Reset.**
  - c. **The Factory Reset will, delete all remotes from the shade memory, and reset all programmed positions to Factory Default settings.**
  - d. **The shade will be in learn mode for adding new remotes for one minute.**
  - e. **Press and Hold the Up Button on a new remote or channel until the shade begins to move Up.**
  - f. **If a new remote is not added within one minute, the shade will exit Learn Mode for Remotes and can only be operated through tugs. A new remote can only be added by performing**
    - i. **2 Button Press procedure with a Multichannel remote or USB remote.**
    - ii. **Removing and reapplying power to the shade, followed by step e. of this section.**





## Brackets (Universal Back Mount)

(Automated and Qfree)

### 2.6 Universal Bracket Back Mount, No Cover

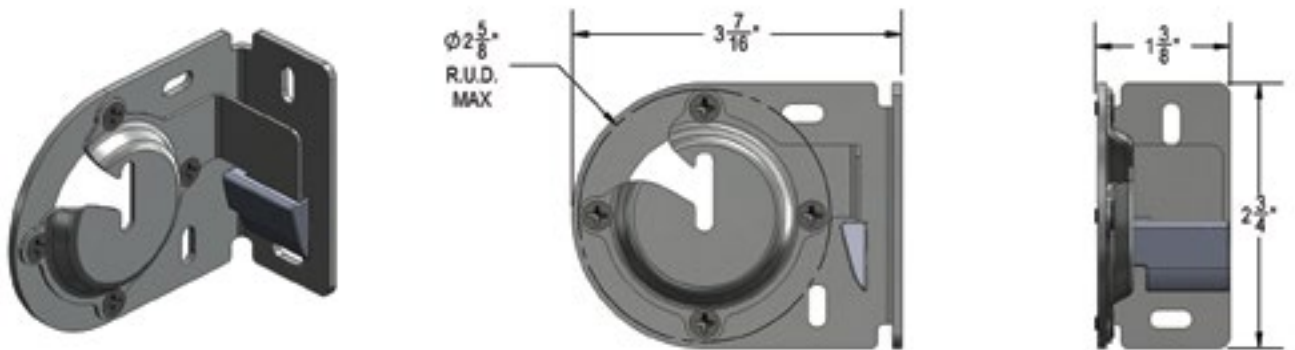

### 2.6 Universal Bracket Back Mount, Cover

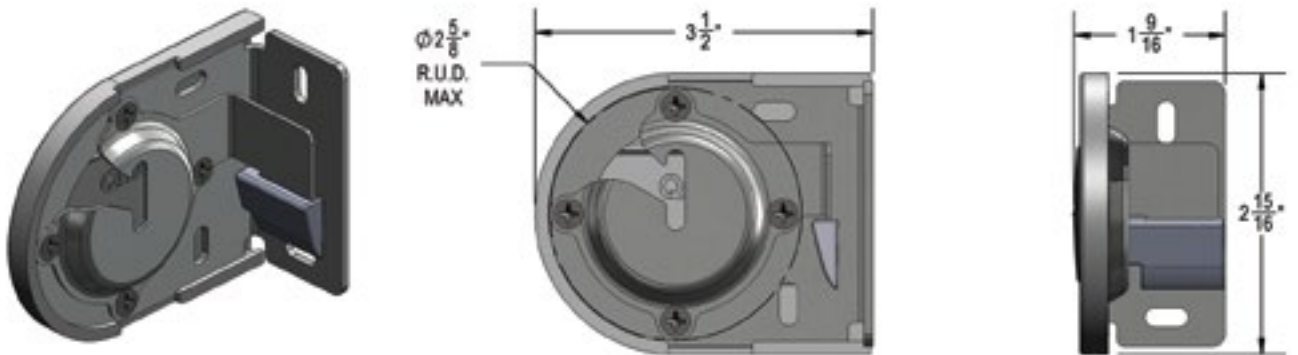

### 2.6 Universal Bracket Back Mount, No Cover, Reverse

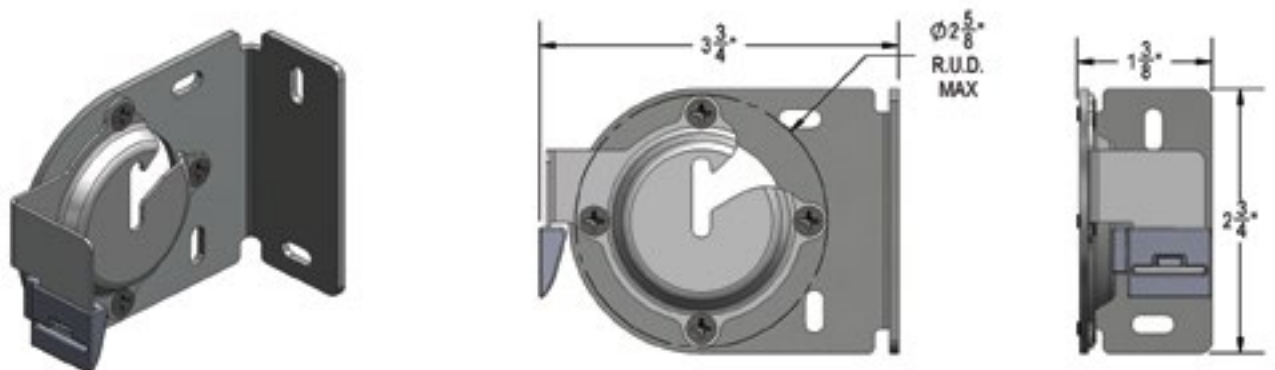



## Brackets (Universal Back Mount)

(Automated and Qfree)

### 2.6 Universal Bracket Back Mount, With Cover, Reverse

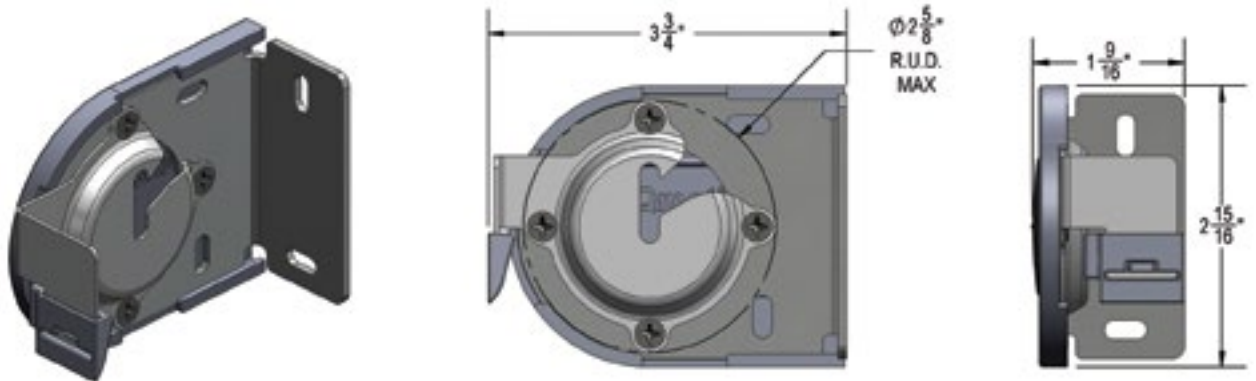

### 3.3 Universal Bracket Back Mount, No Cover

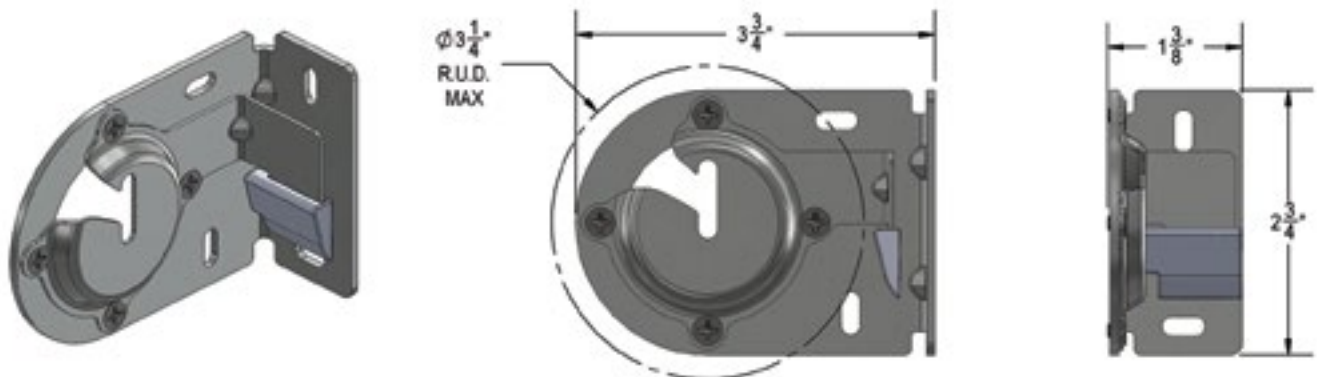

### 3.3 Universal Bracket Back Mount, With Cover

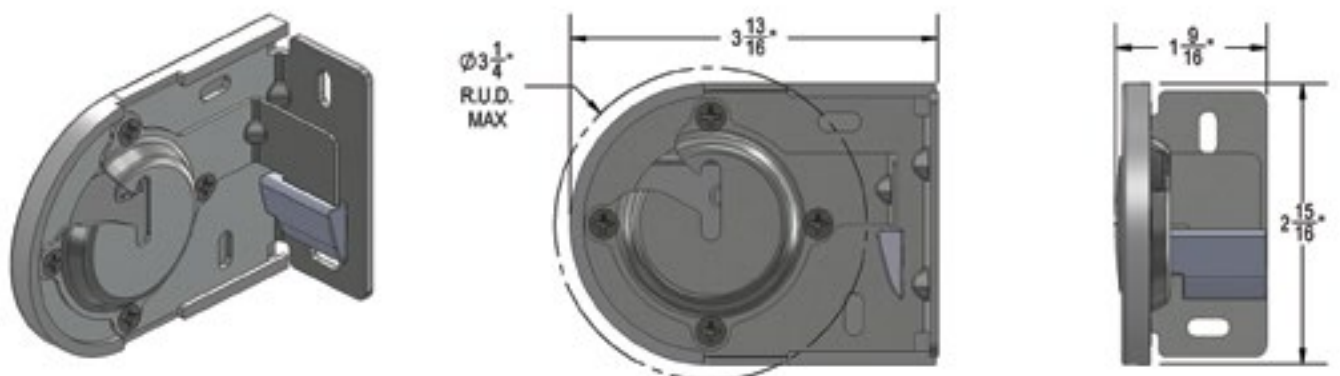



## Brackets (Universal Back Mount)

(Automated and Qfree)

### 3.3 Universal Bracket Back Mount, No Cover, Reverse

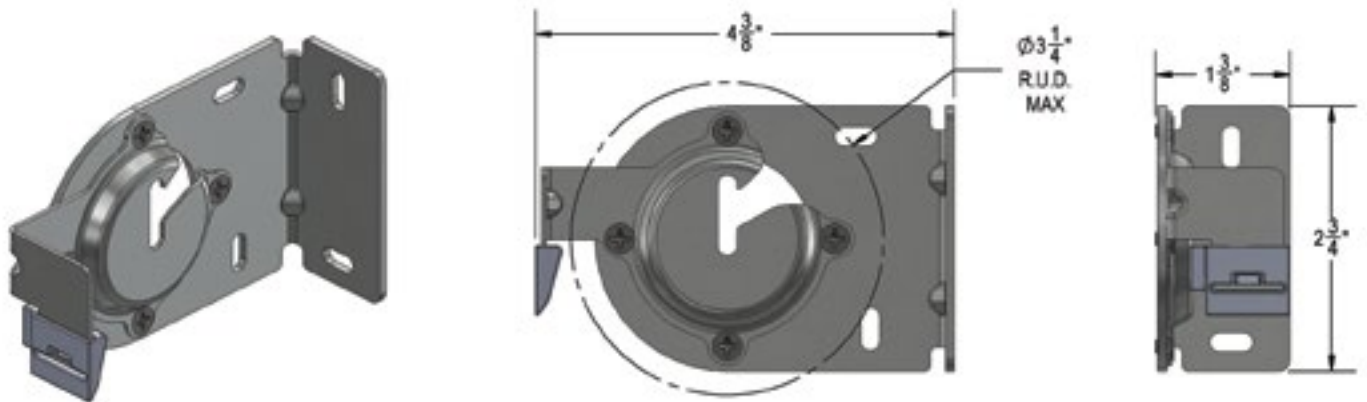

### 3.3 Universal Bracket Back Mount, With Cover, Reverse

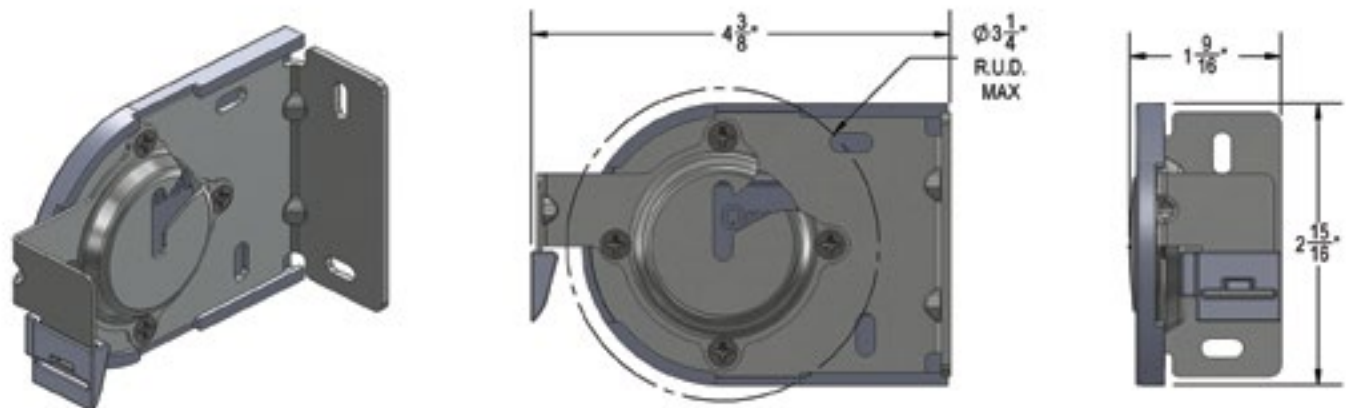





## Brackets (Universal Top Mount)

(Automated and Qfree)

### 2.6 Universal Bracket Top Mount, No Cover

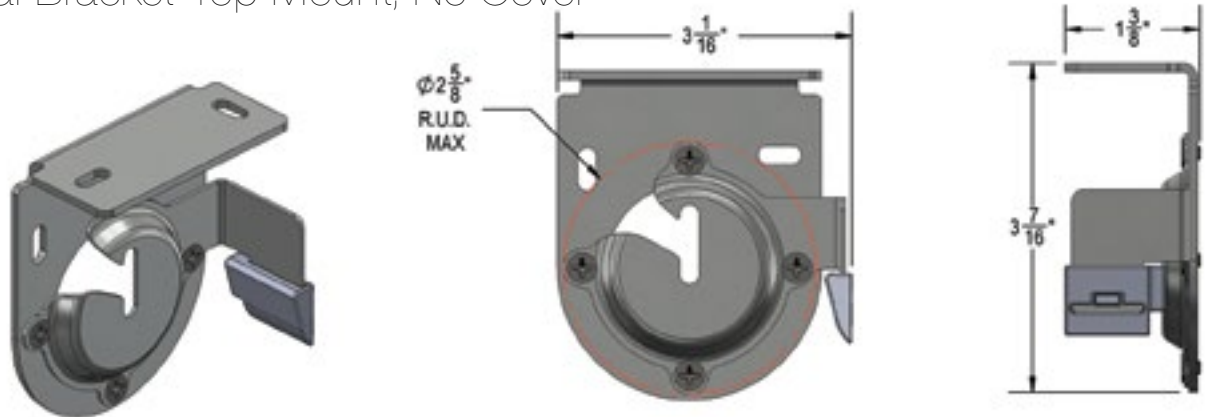

### 2.6 Universal Bracket Top Mount, With Cover

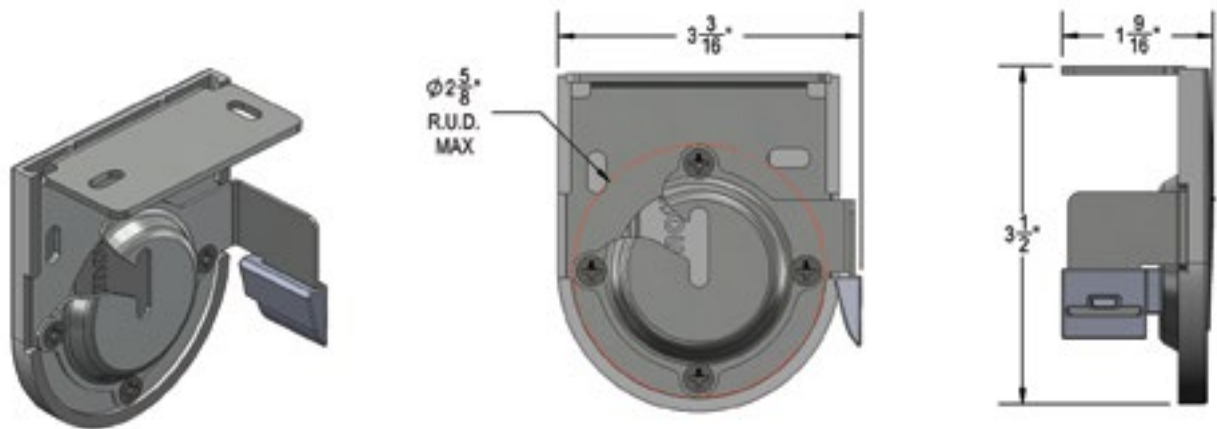



## Brackets (Universal Top Mount)

(Automated and Qfree)

### 3.3 Universal Bracket Top Mount, No Cover

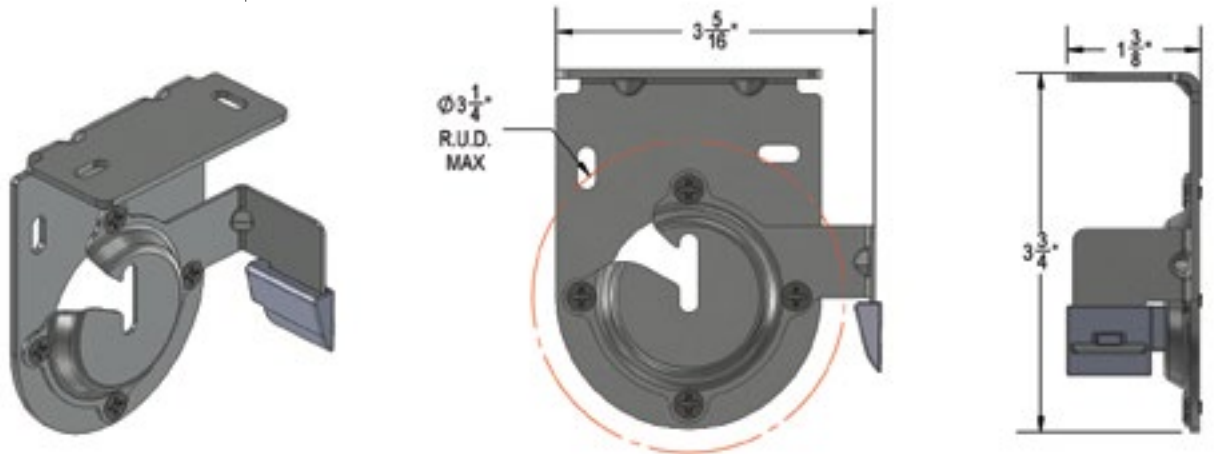

### 3.3 Universal Bracket Top Mount, With Cover

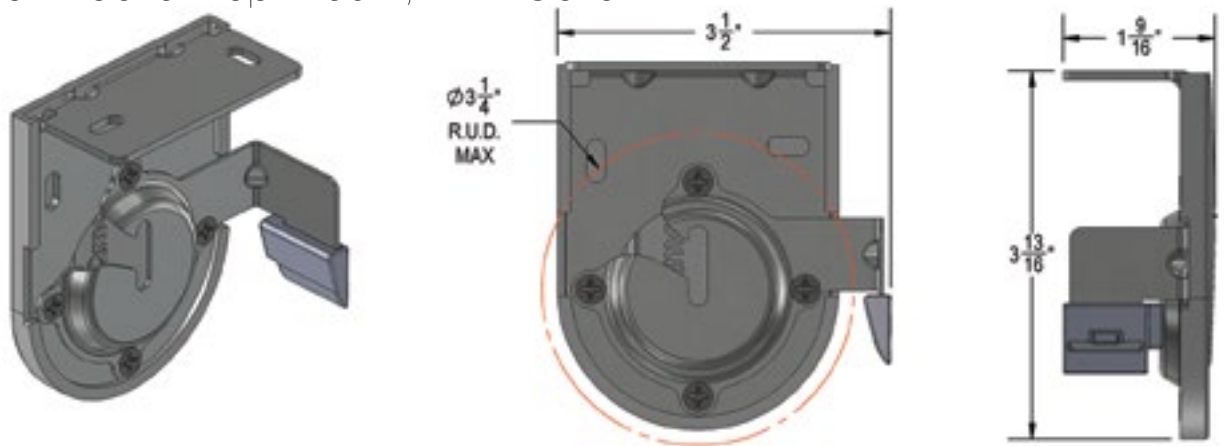



## Dual Brackets

(Automated and Qfree)

### 2.5 Dual Bracket

\*Standard roll application only

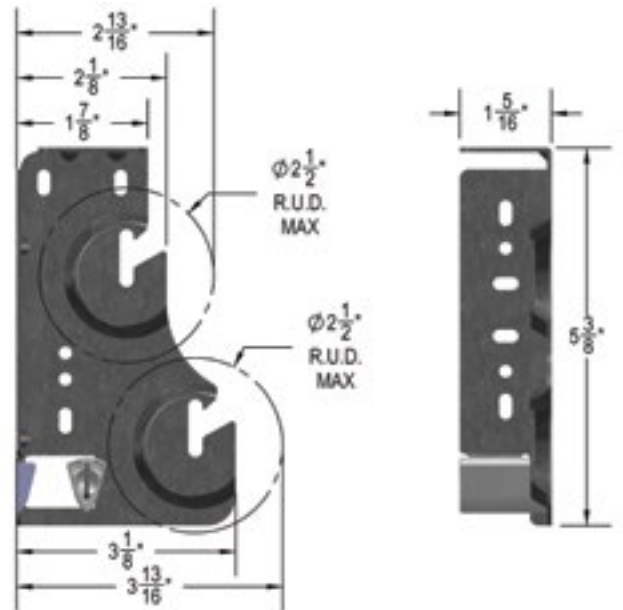

### 3.7 Dual Bracket

\*Standard roll application only

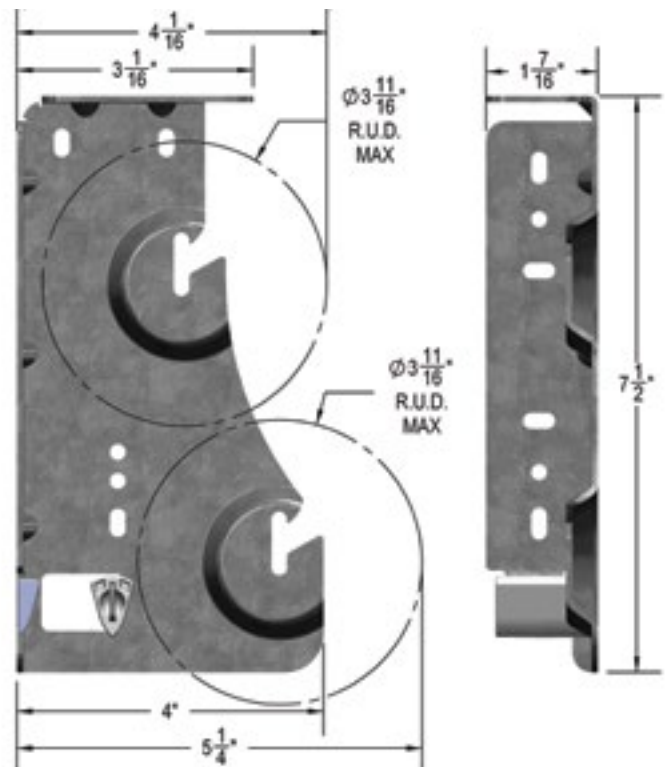



## Brackets (2.5)

Universal Bracket

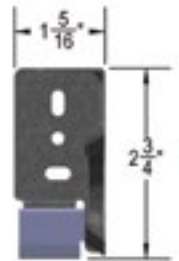
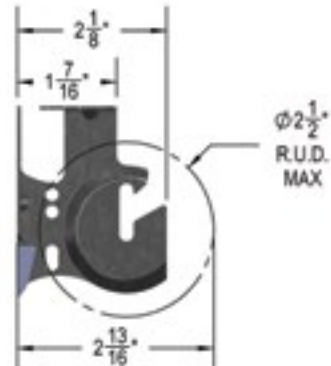

Outside Mount Bracket

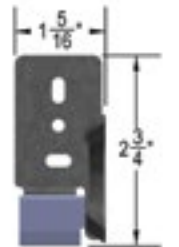
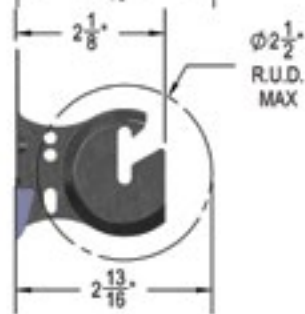

Pocket/Reverse Bracket

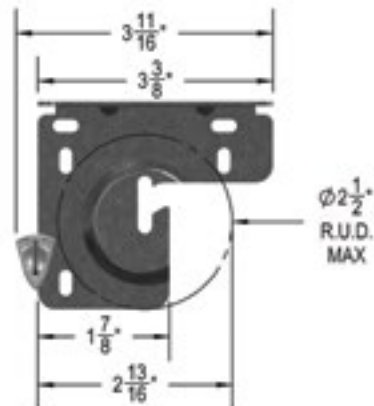





## Brackets (3.7)

Universal Bracket

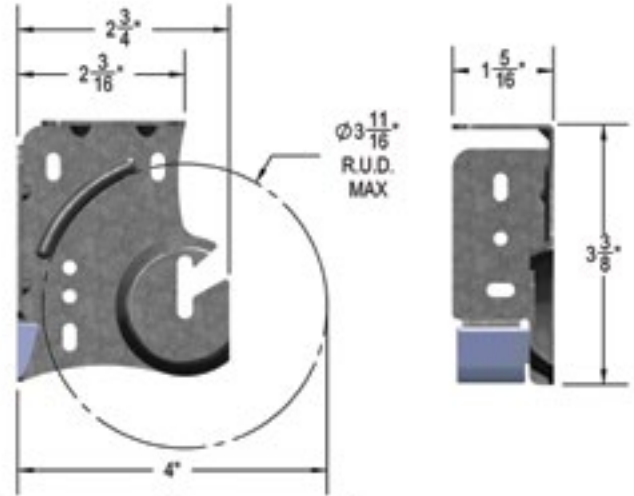

Pocket/Reverse Bracket

\*Some installation may require L-Bracket

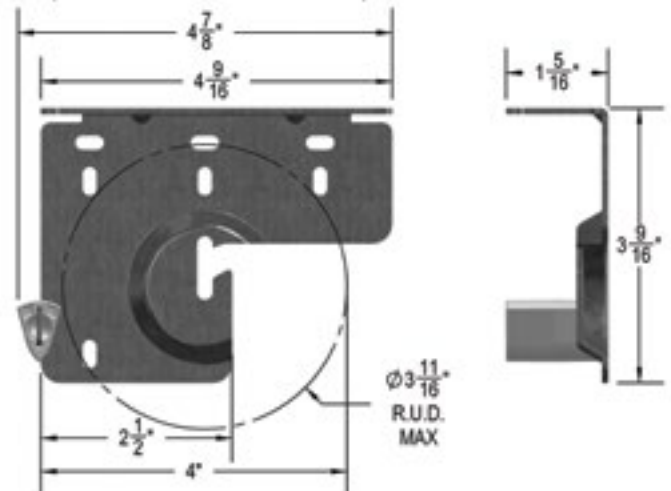



## Fascia Brackets

(Automated and Qfree)

### 2.6 Fascia Bracket

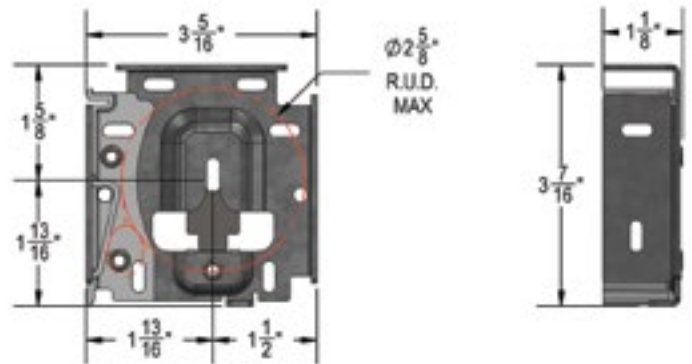

### 3.3 Fascia Bracket

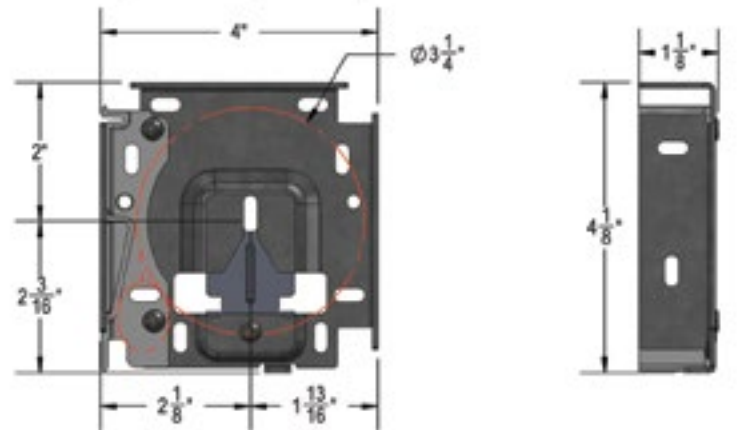

### 4.3 Fascia Bracket

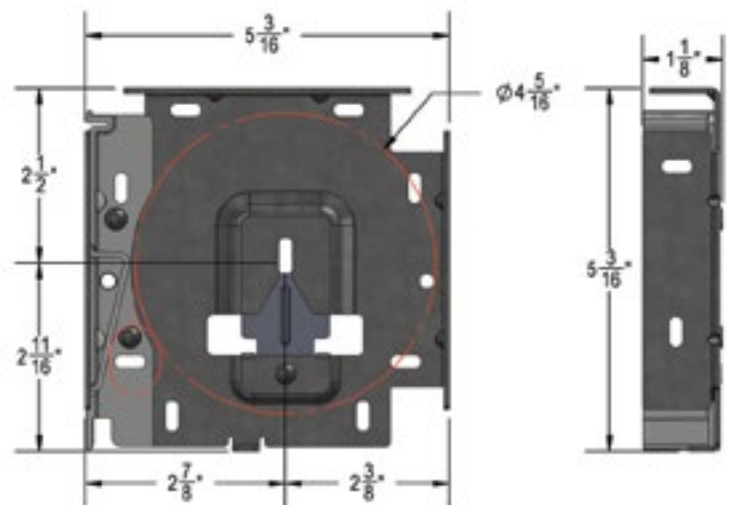



## Cassette

Single Cassette

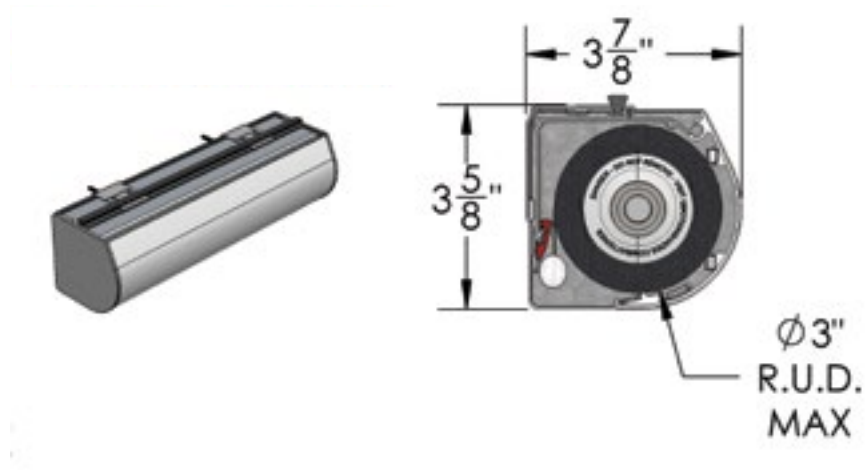

## Qlink

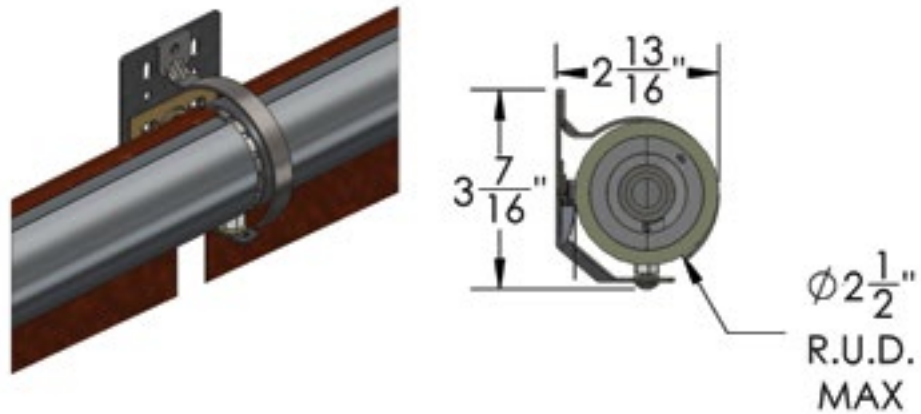

\* R.U.D. indicates the maximum likely diameter on the system. Check fabric charts for specific shade diameters.



## QMotion® Independent Fascia

Standard Fascia

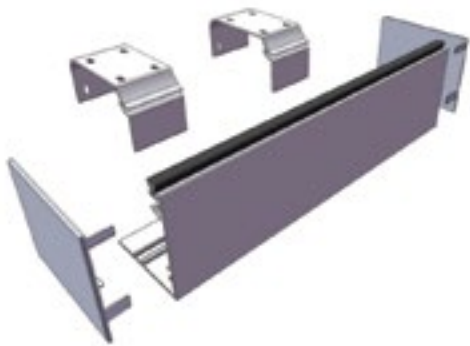

2.5

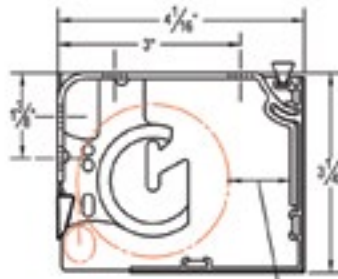

3.7

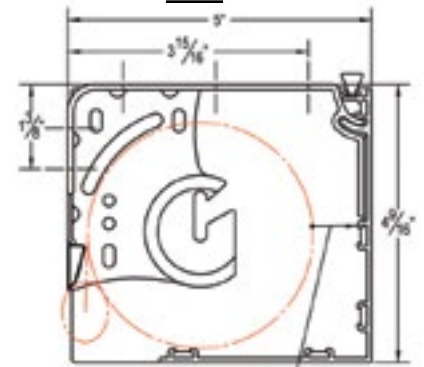

5/16" REQUIRED FOR SHADE REMOVAL

Reverse Fascia

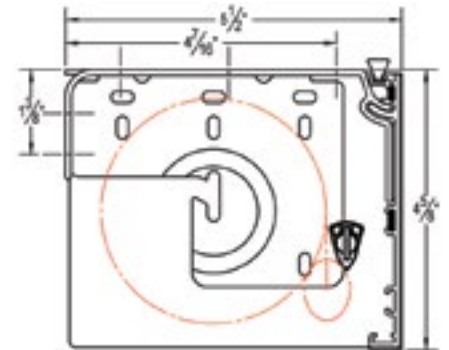
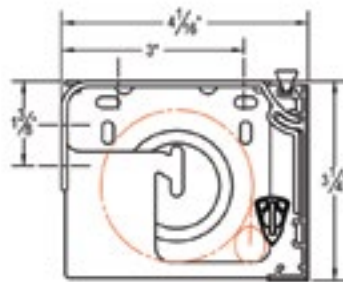
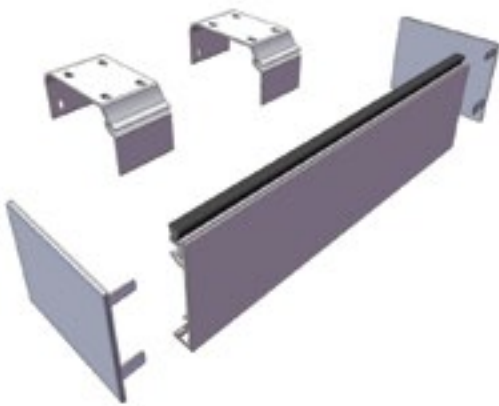

Dual Bracket Fascia

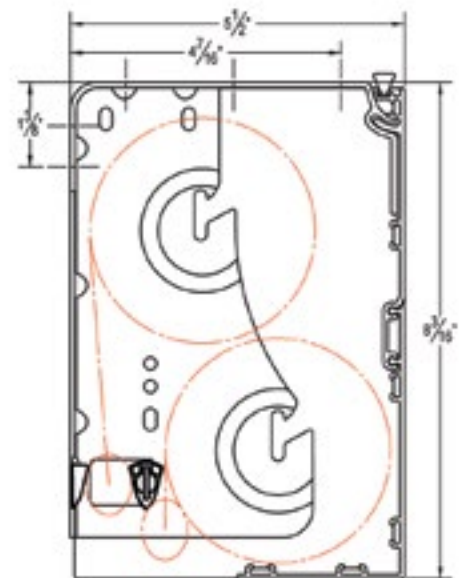
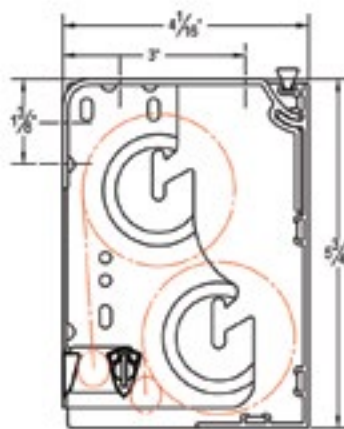
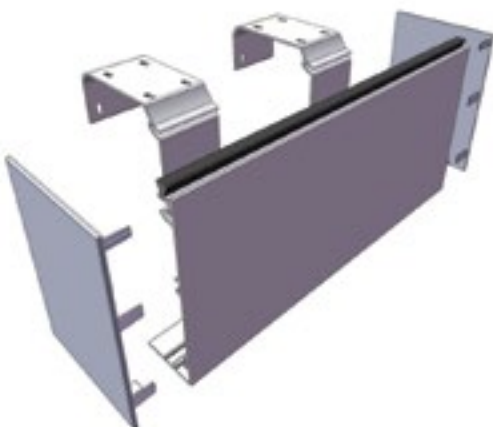





## QMotion® Fascia (2.6")

Standard Fascia



Reverse Fascia

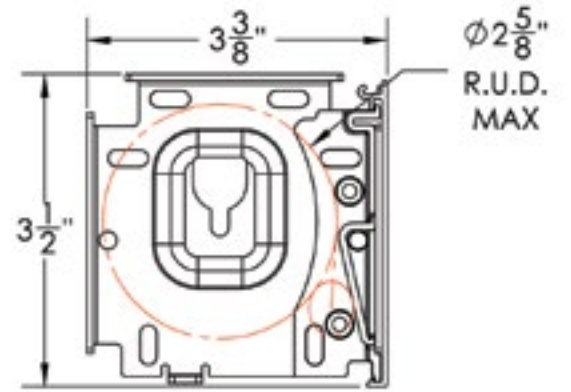
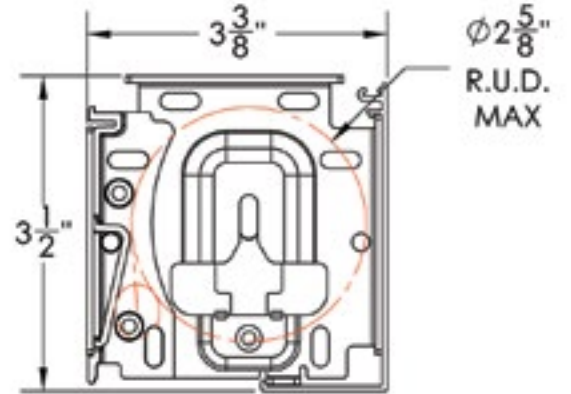



## QMotion® Fascia (3.3")

Standard Fascia

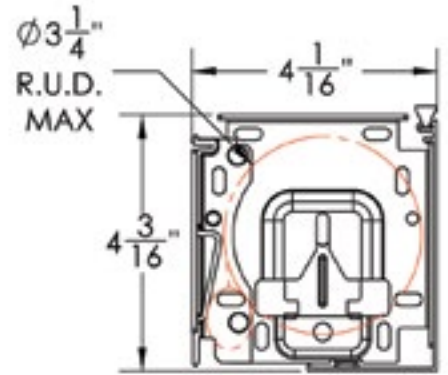

Reverse Fascia

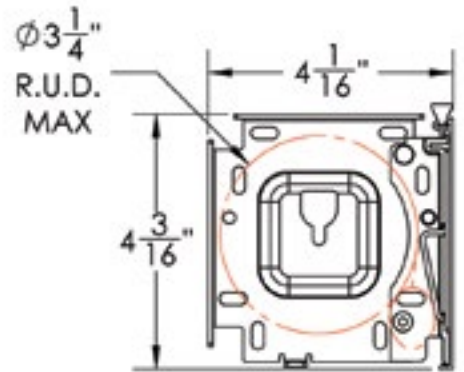



## QMotion® Fascia (4.3")

Standard Fascia

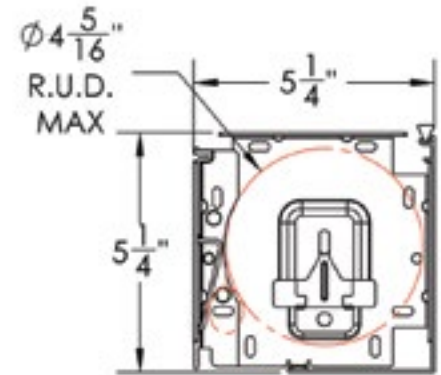
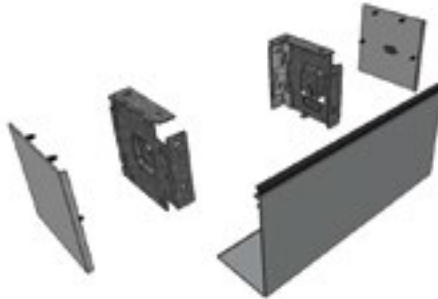

Reverse Fascia

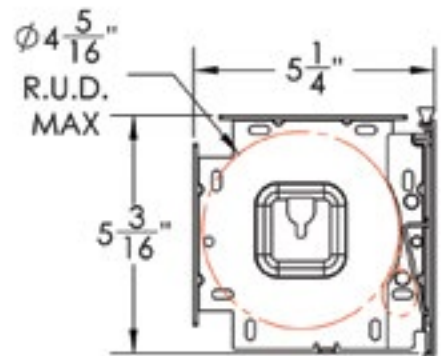
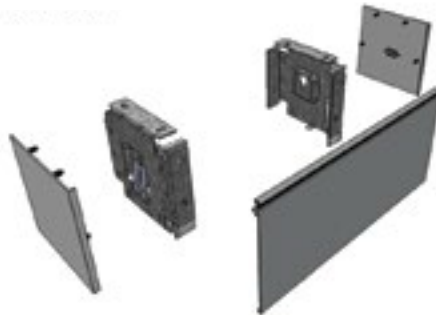



## Qlink Fascia

Standard Fascia

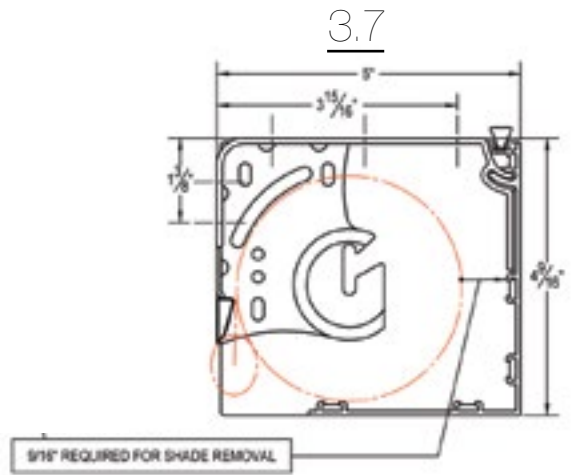
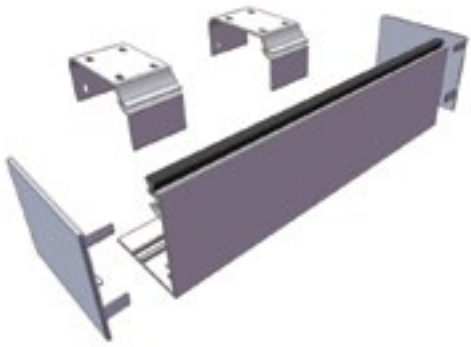

Reverse Fascia

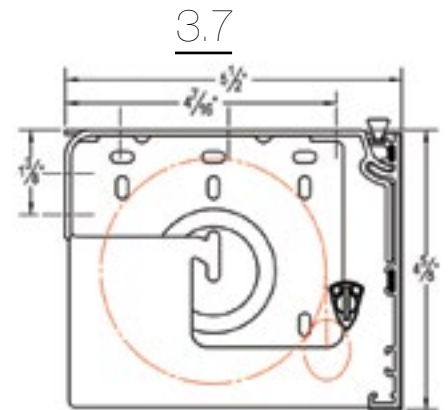
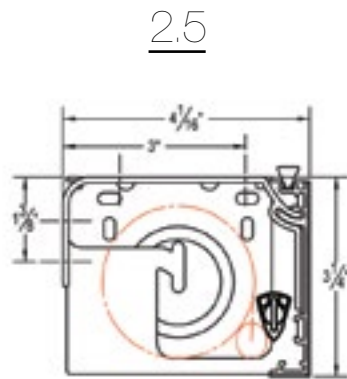
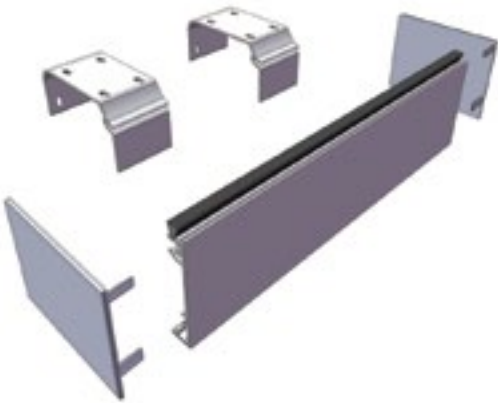





## Qbasic Fascia

QB-17 with Independent/Reverse Fascia

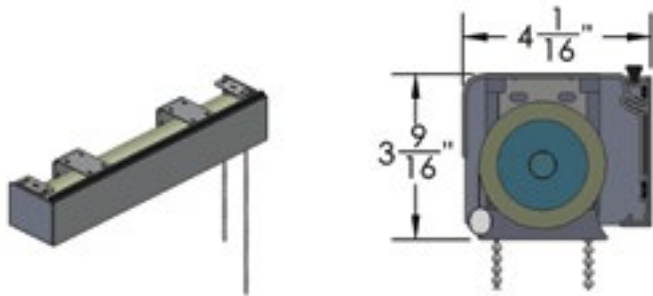

QB-28 with Snap On Fascia

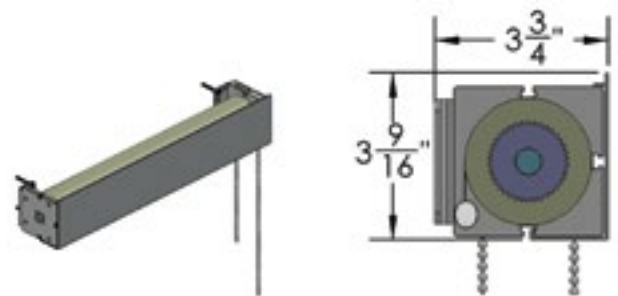

QB-28 with Independent/Reverse Fascia

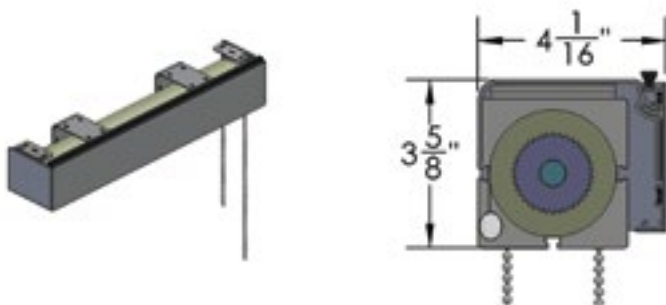

## Shade Mounting Dimensions

For our various shade choices these drawings can help determine the minimum required space in the window for mounting.

Qbasic QB-17

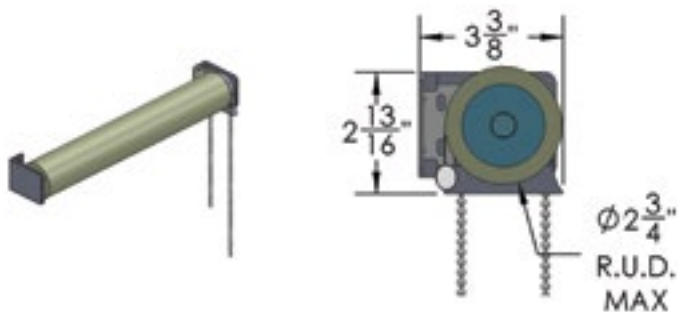

Qbasic QB-28

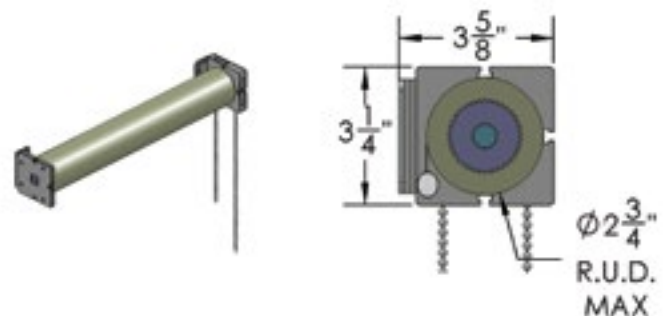

\* R.U.D. indicates the maximum likely diameter on the system. Check fabric charts for specific shade diameters.



## Copyright Notice and Disclaimer

All rights reserved. No parts of this manual may be reproduced in any form without the express written permission of Qmotion®. Qmotion® makes no representations or warranties with respect to the contents hereof. In addition, information contained herein are subject to change without notice. Every precaution has been taken in the preparation of this manual. Nevertheless, Qmotion® assumes no responsibility for errors or omissions or any damages resulting from the use of the information contained in this publication.

© 2013 HomeRun Holdings Corporation. Qmotion® is a trademark of HomeRun Holdings Corporation.

## Environmental Statement

### RoHS COMPLIANT

### WEEE (Waste Electrical and Electronic Equipment) Statement

### Disposal of Waste Equipment by Users in Private Household in the European Union

This symbol on the product or on its packaging indicates that this product must not be disposed of with your other household waste. Instead, it is your responsibility to dispose of your waste equipment by handing it over to a designated collection point for the recycling of waste electrical and electronic equipment. The separate collection and recycling of your waste equipment at the time of disposal will help to conserve natural resources and ensure that it is recycled in a manner that protects human health and the environment. For more information about where you can drop off your waste equipment for recycling, please contact your local city office, your household waste disposal service or the shop where you purchased the product.



## Limited Warranty

HomeRun Holdings Corporation, (the “Manufacturer”) warrants that this Qmotion® window shade product will be free from defects in materials and workmanship for 5 years, beginning from the date first sold to the commercial or residential consumer who has, or intends to, use the product, as evidenced by such consumer’s proof of purchase:

Exclusions From this Limited Warranty: This limited warranty shall be null and void and no part of it shall apply if any one of the following occur: 1) the product has not been properly installed by a qualified installer in accordance with all Manufacturer specifications; 2) the product has been subject to unauthorized service; 3) the product has been subject to mis-handling, misuse, or abuse; 4) the product has been modified; 5) the product has suffered damage resulting from lightning, power surges, vandalism, fire, earthquake, acts of nature, or any other cause which the product was not designed to withstand; 6) the product has been used, or attempted to be used, for other than the customary usage or for other than the product’s intended use; 7) the product has not been maintained; 8) damage to the product caused by battery decay or corrosion.

This Limited Warranty extends only to the original owner. This Limited Warranty is not transferable. This Limited Warranty does not cover normal wear or tear or deterioration which occurs with the passage of time.

Batteries originally provided with a new product, if any, are produced by a third party and are not warranted by Manufacturer.

No employee, distributor, dealer, agent or representative is authorized to change the terms of this Limited Warranty in any way, to extend the warranty time periods, or to grant additional warranties, and no attempt to do any of the foregoing will be binding upon Manufacturer.

**IF THIS LIMITED WARRANTY COVERS A CONSUMER PRODUCT, AS DEFINED BY THE MAGNUSON-MOSS WARRANTY ACT, THEN NO WARRANTIES, EXPRESSED OR IMPLIED (INCLUDING, BUT NOT LIMITED TO, THE WARRANTY OF MERCHANTABILITY OR FITNESS FOR A PARTICULAR PURPOSE) SHALL EXTEND BEYOND THE APPLICABLE TIME PERIOD STATED IN BOLD FACE TYPE ABOVE. IF THIS LIMITED WARRANTY COVERS A COMMERCIAL PRODUCT, THEN THIS LIMITED WARRANTY IS IN LIEU OF ALL OTHER REPRESENTATIONS, GUARANTEES, OR OTHER EXPRESS OR IMPLIED WARRANTIES (INCLUDING, WITHOUT LIMITATION, THE WARRANTY OF MERCHANTABILITY OR FITNESS FOR A PARTICULAR PURPOSE) AND ALL SUCH OTHER EXPRESSED OR IMPLIED WARRANTIES ARE HEREBY SPECIFICALLY DISCLAIMED.**

Claims for defects in material and workmanship covered by this Limited Warranty must be made in writing to the dealer from whom the product was originally first purchased within the warranty period stated above. Manufacturer may either send a service representative or have the product returned to Manufacturer’s



facility, at Buyer's expense, for inspection. If judged by Manufacturer to be defective in material or workmanship, and to otherwise be covered by this Limited Warranty, the product will be replaced or repaired at the option of Manufacturer, in its sole and absolute discretion, free from all charges except authorized transportation and replacement labor. Replacement labor, transportation costs, and any other costs or charges by the dealer, wholesaler, distributor, contractor, or installer are not covered by this Limited Warranty. Any replacement unit may be a model determined by Manufacturer to be equivalent to the defective model, or a product that has been factory refurbished. The remainder of original warranty period will apply to any repair/replacement unit.

THE REMEDIES OF BUYER SET FORTH IN THIS LIMITED WARRANTY ARE EXCLUSIVE AND ARE IN LIEU OF ALL OTHER REMEDIES. THE LIABILITY OF MANUFACTURER WHETHER IN CONTRACT, TORT, UNDER ANY WARRANTY OR OTHERWISE, SHALL NOT EXTEND BEYOND ITS OBLIGATION TO REPAIR OR REPLACE, AT ITS OPTION, ANY PRODUCT OR PART FOUND BY MANUFACTURER TO BE DEFECTIVE IN MATERIAL OR WORKMANSHIP AND OTHERWISE SUBJECT TO THIS LIMITED WARRANTY. MANUFACTURER SHALL NOT BE RESPONSIBLE FOR ANY DIRECT, INDIRECT, SPECIAL OR CONSEQUENTIAL DAMAGES OF ANY NATURE.

This Warranty gives specific legal rights and Buyer may have other rights, which may vary from state to state. However, some states do not allow limitations on how long an implied warranty lasts or the exclusion or limitation of incidental or consequential damages so the above limitations or exclusions may not apply specific buyers.



3400 Copter Road  
Pensacola, FL 32514  
Ph: 877.849.6070  
Fax: 850.208.3409  
[qmotioninfo@qmotionshades.com](mailto:qmotioninfo@qmotionshades.com)

[qmotionshades.com](http://qmotionshades.com)