



Alumatec Pacific Products
1155 West 500 North
Centerville, UT 84014
Phone: 801-298-0181
Fax: 801-298-0905
Email: info@alumatecpp.com

INSTALLATION INSTRUCTIONS

COUNTER SHUTTER:

Model: PFC-20, PFC-30, S2 shutter

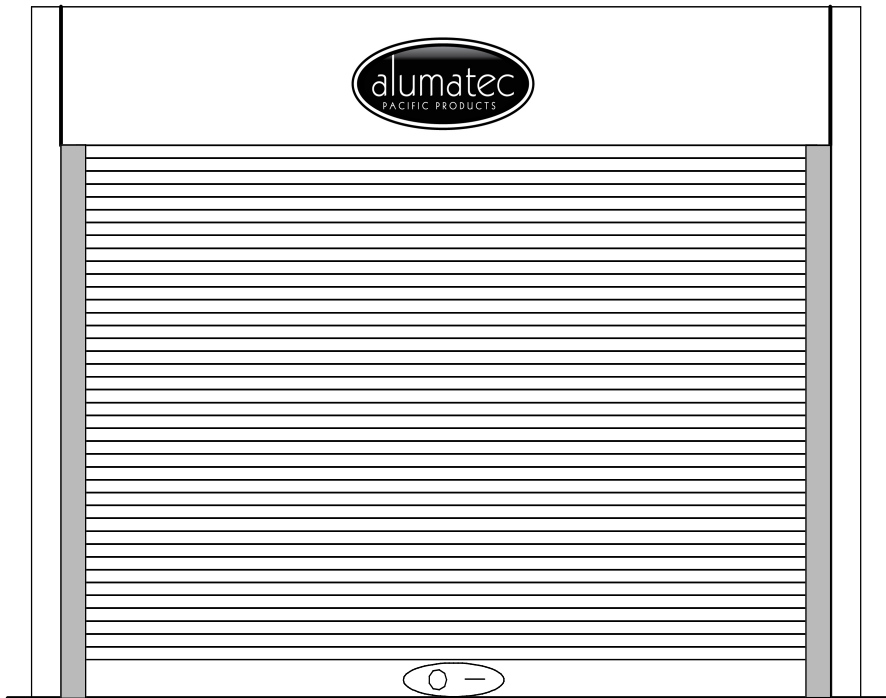

IMPORTANT:

PLEASE READ THE COMPLETE INSTRUCTIONS BEFORE ATTEMPTING INSTALLATION

1. If you are installing more than one door, you will find that all major parts and pieces for any other door(s) are marked with corresponding numbers or letters; therefore, a complete door should be composed of parts and pieces bearing the same number or letter. **DO NOT** interchange parts from one door to another.
2. Study all the drawings and familiarize yourself with the various parts and names involved.
3. Check the packaging and hardware list showing materials received. Report any shortage at once. Your door may or may not come with wall bolts. If wall bolts are provided, they have been provided based upon available information and may or may not be suitable for jobsite conditions. If you are providing the wall bolts and/or you are not sure about what type or size should be used, consult the factory.
4. When the instructions refer you to the right or left side of the door, it will be facing the door as it is mounted on the wall (Coil side).
5. During installation, remember that all guides, brackets, barrel and components must be installed so that they are plumb and level.
6. Your door may be provided with a backhood/fascia. If so, determine how if it has to be installed prior to the installation of the door itself.
7. CAUTION- the barrel weight is not symmetrical about the centerline. The barrel is heavier on the tension end.
8. Personal and equipment safety rules should be adhered to at all times. Depending on the size of the door, you may need assistance and/ or equipment to safely install the door. The door manufacturer recommends that at least two qualified individuals install the door.

GENERAL TERMS

- A. Right Hand(R/H) and Left Hand (L/H) are to be read looking at the grille/opening from the inside (hood or coil side.)
- B. The "Drive" side of the grille, regardless of interior or exterior installations, determines hand of operation.
- C. Manual operation is to be considered as Push Up, Manual Hand Chain is simply Chain Operation, and Motor Operation is as stated. Crank Operation is assumed to be Awning Crank unless otherwise noted.
- D. The barrel is the complete drum assembly upon which the curtain coils; the shaft is the solid steel protrusion that carries the barrel assembly.
- E. Head Plates are to be referred to as Bracket Plates.(this is what holds the barrel in place)
- F. The foot-piece is identified as the Bottom Bar
- G. The adjusting wheel is to be referred to as the Tension Wheel

Study all drawings and familiarize yourself with the various parts and names involved (see details provided on the following pages). All shutter parts are to be inspected prior to installation to insure that none of the components have been damaged in shipment. Damages are to be reported immediately and damaged components are not to be used to install grille(s).

During installation, all guides, tubes, brackets and barrels are to be installed plum and level. Alumatec Pacific Products cannot warranty the use of any grille where these components have been installed out of level, not plum, or not set to the proper distance apart. Most grilles consist of two (2) mounting tubes, two (2) guides, two (2) bracket plates, one (1) barrel assembly, and one (1) curtain.

INSTALLATION

Note: As most shutters are installed on counter tops these instructions will assume those mounting conditions. Use the correct heel dimension as shown on the plan view. Care should be exercised to insure that the wall angles are plumb and adequate side clearances are provided.

- STEP 1** Locate the centerline of the opening at the top of the opening. Use a plumb bob to locate the center of the opening on the sill. Locate the heel dimension on the plan view drawing. THIS DIMENSION IS CRITICAL. Measure from center line $\frac{1}{2}$ the heel to heel wall angle dimension as shown on the plan view, Mark this at the top and bottom of the opening. NOTE: In some cases the heel to heel dimension is offset from the centerline. This will also be shown on the plan view.
- STEP 2** Look at the floor plan to see which guide is for the left and which is for the right. Take the guides apart and stand the wall angles against the wall and align the back of the wall angle with the heel to heel marks that you put on the wall. Make sure the angles are plumb. Check the heel to heel angle dimension, both top and bottom
- STEP 3** Check the sill for level. DO NOT ASSUME THE COUNTER IS LEVEL! Raise one wall angle to compensate. The top of the wall angles should be in alignment with each other. Use a chalk line from top and bottom holes to check that all holes are in line, mark each hole for drilling.
- STEP 4** Check oversteps 1, 2, & 3. Alumatec Pacific Products cannot warranty the use of any door that has wall angles that are not plumb, level or not set the proper distance apart.
- STEP 5** Drill wall bolt holes. IF your door is provided with a back-hood/fascia and you have determined that it must be installed prior to the door itself, install it now. Some installations require that the back-hood/fascia be between the wall angles and the wall. Bolt the wall angles into place.

Step 6 MANUAL PUSH UP DOORS- there is no assembly of the gear bracket required

CRANK OPERATED DOORS - Assembly of the gear bracket is done after the bracket is attached to the barrel. Install the gear, and attach the crank box to the outside face of gear bracket with $\frac{1}{4}$ " x 1 $\frac{1}{4}$ " round head bolts and lock washers, as shown.

MOTOR DOORS – Assemble the gear bracket. When provided, install the motor operator mounting angle to the front of the gear bracket with $\frac{1}{2}$ " x $\frac{3}{4}$ " hex bolts, flat washers and lock washers as shown. You may elect to install the motor at this point.

STEP 7 Note- The barrel is marked, install to right side or install to left side. Refer to the drawings for proper correlation sides. These instructions are based upon you facing the coil side of the door. The gear bracket goes on the (right, left) end of the barrel. Install the spacer (when referenced by the drawing) between the gear bracket and the barrel stub end. The tension bracket goes on the opposite end of the barrel (same side of the barrel as the factory installed tension wheel). The tension bracket needs to be installed so the welded or cast iron hub of the bearing is inside toward the barrel. When provided, put the gear/driven sprocket on the stub end, align the keyways. Insert the key into the slot (and the crank box now). The barrel should be snug toward the gear bracket so it is approximately centered between bracket plates. CAUTION- the barrel weight is not symmetrical about the centerline. The barrel is heavier on the tension end. The top slat of the curtain is punched to match the curtain fastening screws in the barrel. These are the machine screws and washers that are inline on the barrel. Remove the screws and washers and save them for attaching the curtain.

STEP 8 Hoist the barrel and brackets together and attach the brackets to the wall angles using screws, as shown MAKE SURE THE BRACKETS ARE ATTACHED TO THE CORRECT SIDE OF THE WALL ANGLES as referenced by the drawings. CAUTION-make sure the brackets don't fall off the shaft during hoisting.

STEP 9 After bolting the brackets into place, check to make sure there is clearance between the tension bracket hub and the barrel. It is extremely important to have the barrel level and rotating freely. Re-check for level and adjust if necessary. Try barrel to be certain that it turns freely-if not, check the installation of the brackets and wall angles for plumb and square.

STEP 10 Align all sprockets. Install and adjust the roller chain for motor operated doors. Double check all bolts, If your door has a hood and is provided with hood supports, you may want to lay out the support(s) now and pre-drill the mounting holes. An easy method for determining the line of hood across the opening is to use a chalk line from the top of each wall angle. Measure the hood to determine the proper location of the hood support(s).

- STEP 11** Using two or more ropes make slings of equal lengths to hang off the barrel. The rope slings will be used for installing the curtain. You must use slings that will safely handle the weight of the curtain. With the curtain rolled up (as shipped from the factory). Place it in position below the barrel. Lift the curtain with the top slat pointing away from the opening and suspend it in the rope slings approximately two feet beneath the barrel.
- STEP 12** The curtain **MUST** be centered between the brackets. Measure each side to make sure you have the same distance between the curtain and the brackets on each side. **NOTE:** counter doors with inside tension have top slat shorter than the rest of the curtain – space slats to center curtain between the brackets.
- STEP 13** Raise the top slat up between the barrel and the wall and attach it to the barrel with the machine screws and washers that you removed from the barrel. Use only those screws and washers that were provided. If other type or length of screw is used, they may impede the operation of the internal torsion spring. Check the curtain again to make sure it is centered between the brackets.
- STEP 14** With the curtain attached to the barrel and supported by the rope slings, roll the curtain onto the barrel. Rotate the barrel or use the crank (when provided) to coil the curtain around the barrel until the foot piece hangs down approximately 3” below the opening. Tie the curtain to prevent uncoiling.
- STOP 14(A)** **Charge the tension in the barrel before installing the guides. Remove the ropes holding the curtain in place and CAREFULLY lower the door down to the counter, or until the door is as far down as it can go. The curtain should be hanging off the back-side of the barrel assembly at this point, exposing the tension wheel and tension pin which is the “U” shaped saddle welded to the head plate. Charge the tension while holding the curtain in the closed (shut) position until you can feel the curtain wanting to raise. Once the guides are attached to the jamb / or wall angle, it is not possible to add or take off tension. The tension wheel will be behind the curtain. So make sure the door is balanced before installing the guides.**
- STEP 15** Assemble the guides as referenced by the drawings. The foot piece should be in the guide groove and about three (3) inches below the stop holes. Install the stops using bolts indicated on the hardware sheet.
- STEP 16** Remove slings. **CAREFULLY** untie and lower the curtain until the foot piece is on the sill. **CAUTION-** curtain is heavy and will roll off the barrel fast if lowering the curtain is not carefully controlled. Continue charging the tension. Make sure that your ladder is secure and you have firm footing. Use the ½” tension key and a tension bar of appropriate size or two tension bars. Turn the tension wheel in the direction shown, keeping count of the number of turns. Take in tension until the foot piece raises off the sill. **USE EXTREME**

CARE IN TAKING IN OR LETTING OUT TENSION. Once you have the wheel and the welded channel or cast hub on the tension bracket.

- STEP 17** Try the door. Operate the door to find a satisfactory operation. Adjust the door operation by taking in or letting out tension, but allow only one hole of adjustment at a time.
- STEP 18** If the door is motor operated and the electricity will not be hooked up at time of installation, adjust the limit switches so that the micro switches engage when the foot piece is approximately one foot from the floor or sill and just below to stops. Double check the roller chains and bolts.
- STEP 19** If the door is provided with hood supports, please use them. Attach each support to the wall with the appropriate hardware and place the hood over the support. If the door came with a sheet metal cover (hood), install it now by placing it over the bracket bands and securing it in place with the #10 x 3/8" sheet metal screws. If the hood is in more than one piece, one side is slightly larger than the other and will overlap at the hood support. Install any gear, tension or motor cover now.
- STEP 20** Check all locking devices provided. Install or attach all other accessories/ options and insure they are functioning properly.
- STEP 21** The installation is now complete.

SHUTTER OPERATIONS

Manual shutters are operating properly when:
when:

- A) Curtain stays open without drifting down
- B) Curtain has slight lift in closed position
- C) Curtain operates without excessive force
- D) Curtain opens and closes without catching/binding
- E) Curtain is level in full open and full closed position

Motor operated shutters are operating properly

- A) Curtain opens without slamming stops
- B) Curtain closes without buckling curtain
- C) All switches operate properly
- D) Panic Release allows curtain to rise off floor
- E) All manual operations apply

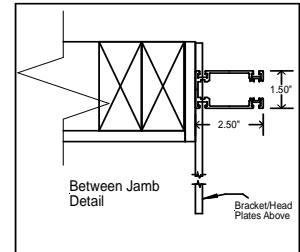
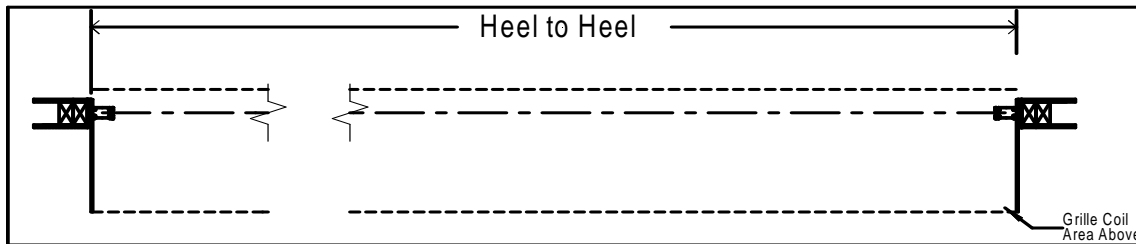
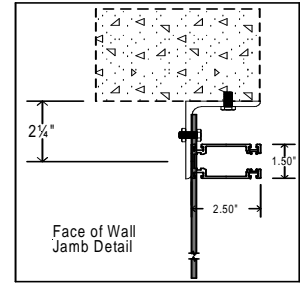
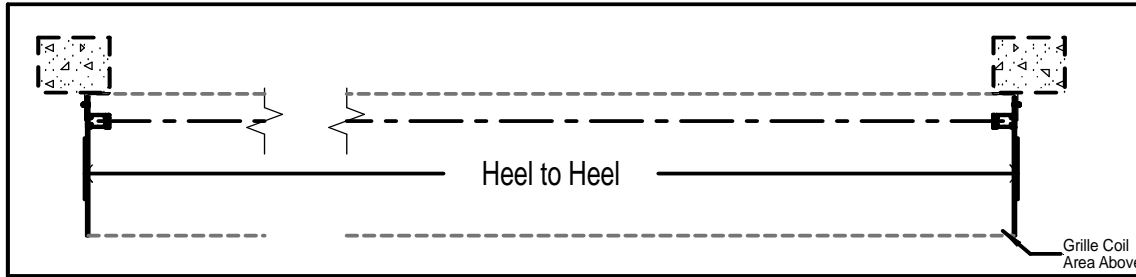
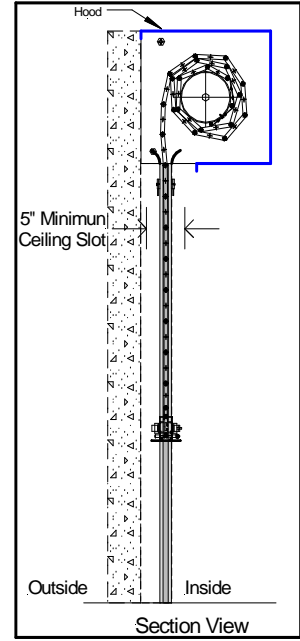
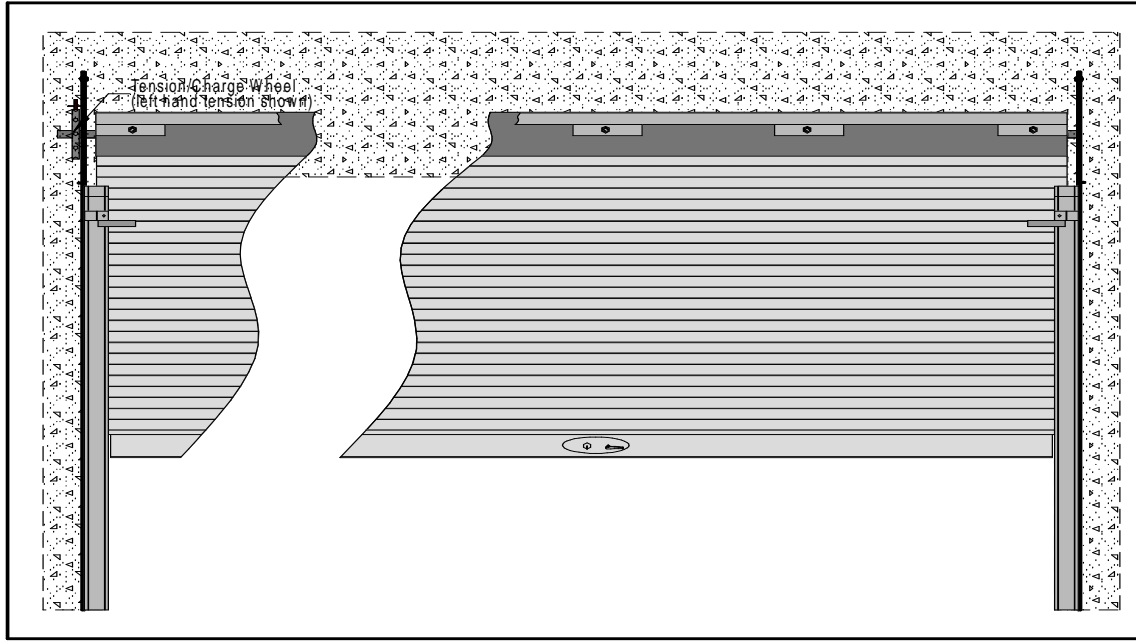

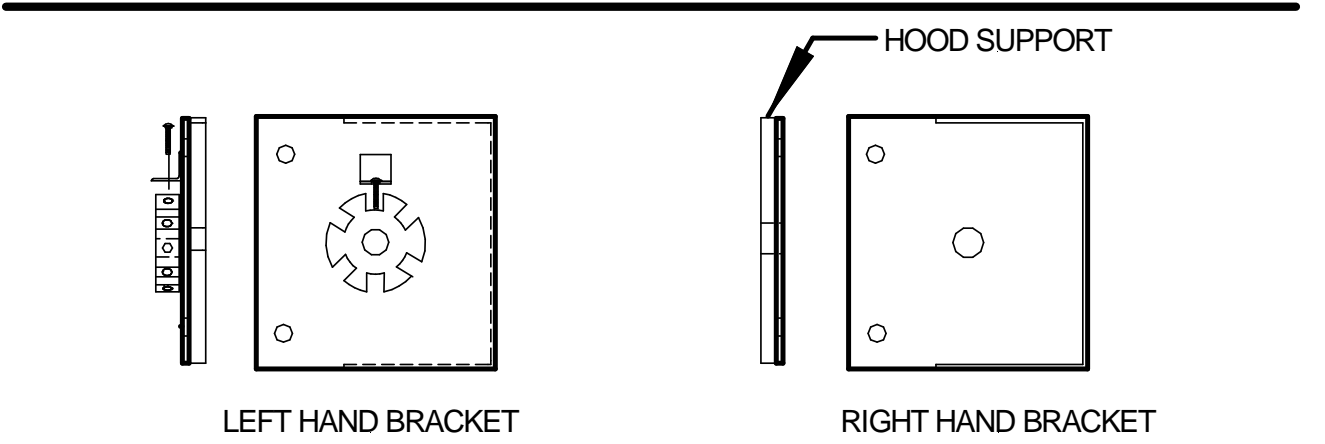
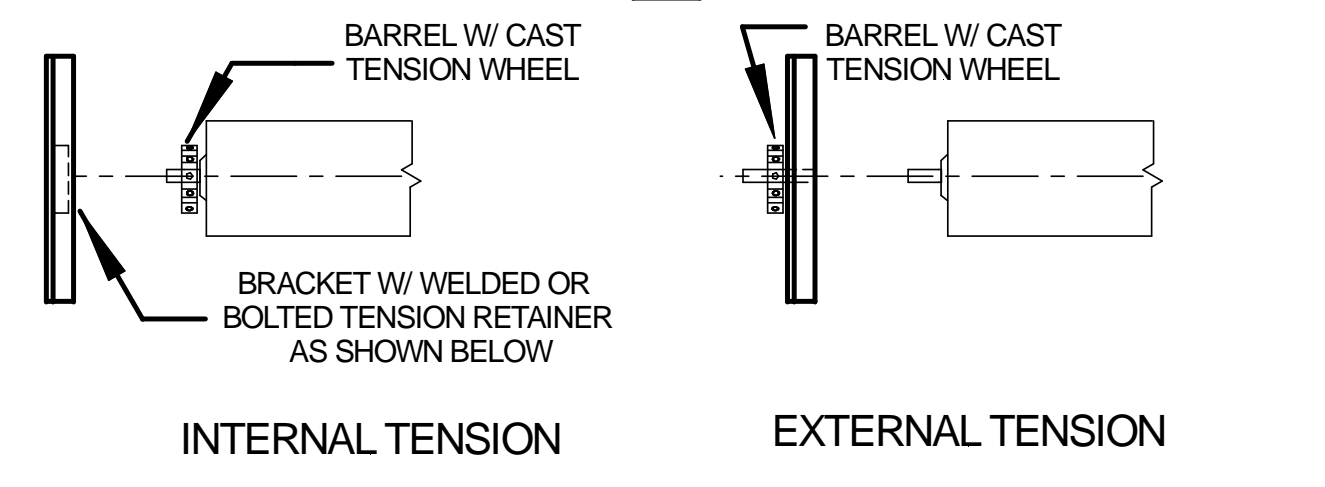
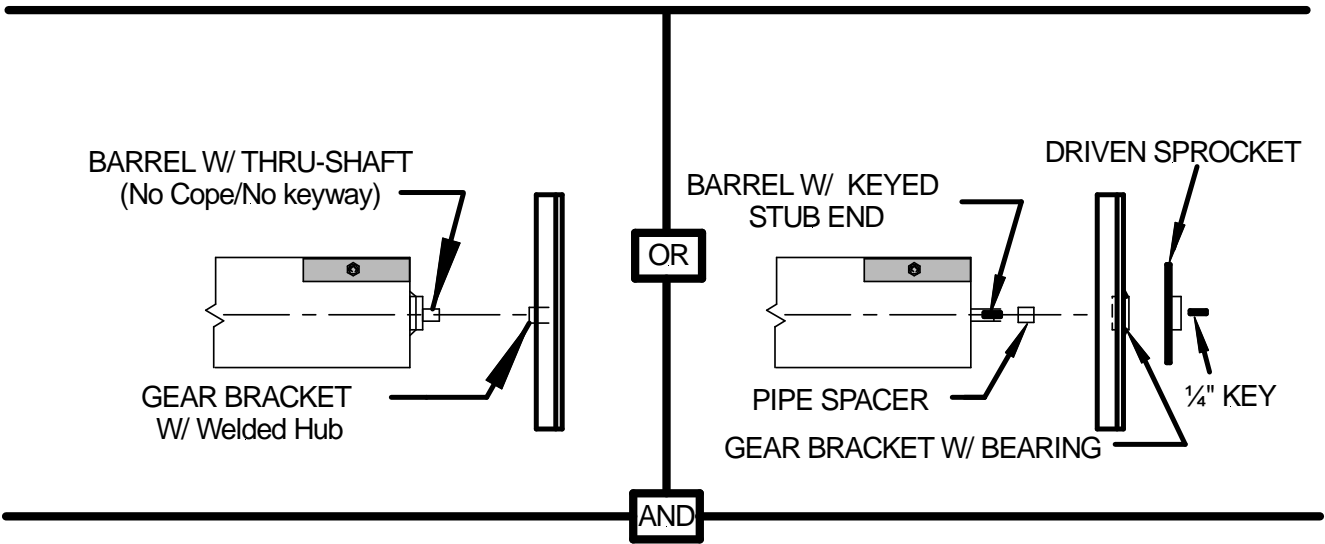

NOTE: DRAWINGS REFER TO R/H OPERATION-L/H OPPOSITE

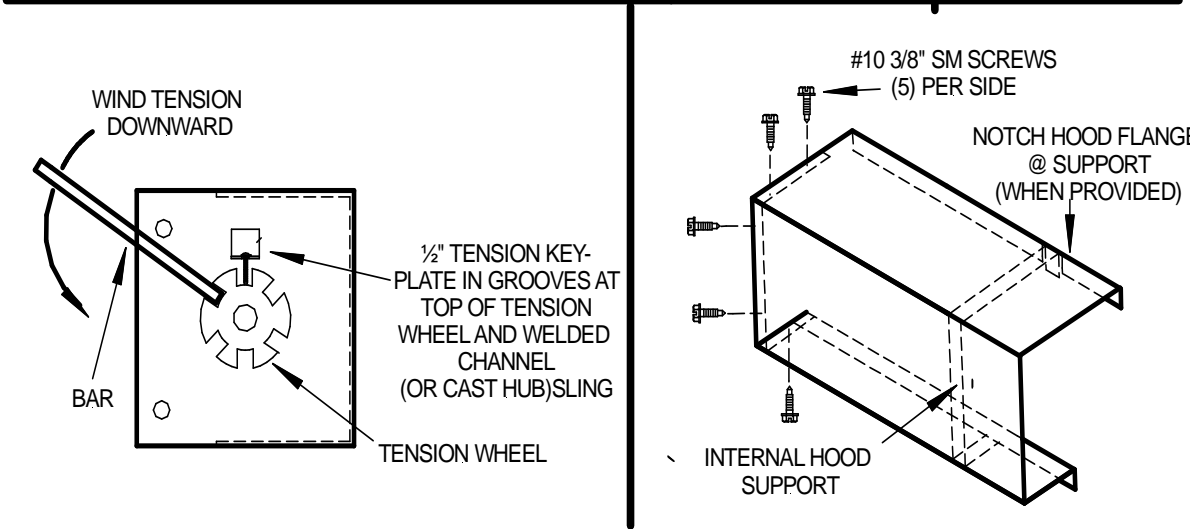
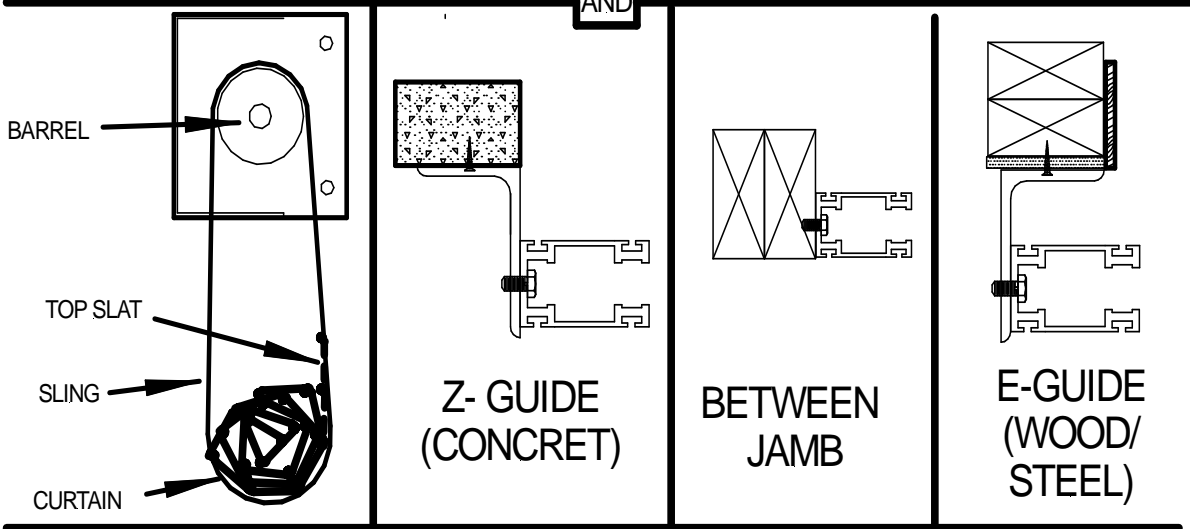
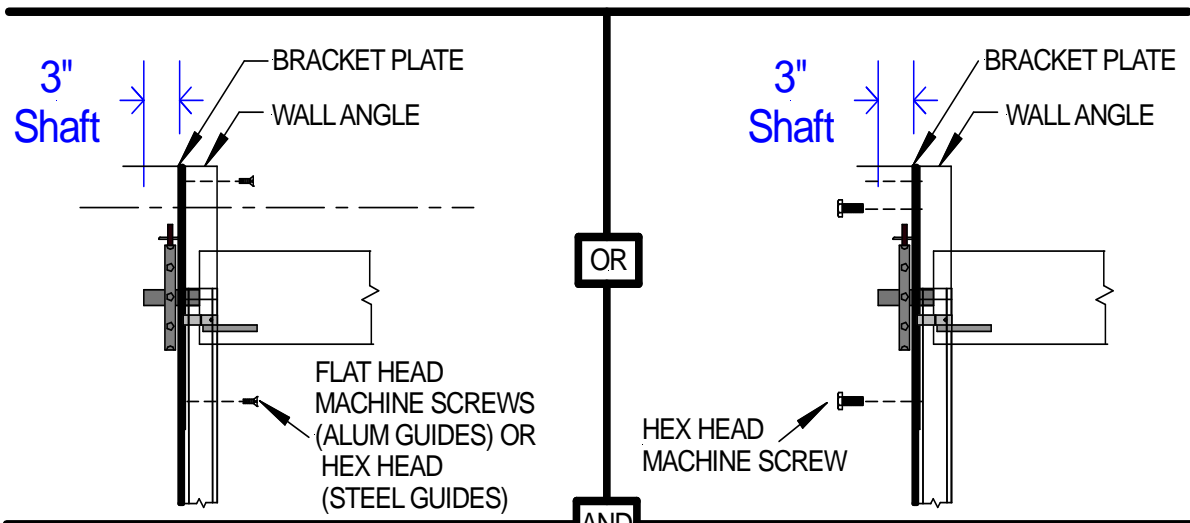

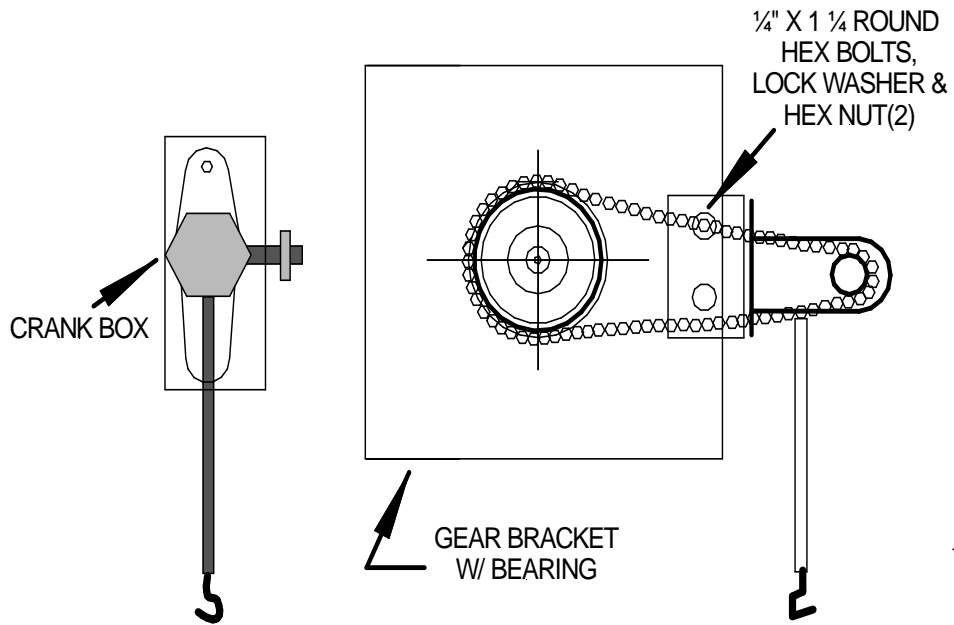

MANUAL CRANK OPERATION

