

NOTE: DIMENSIONS ARE IN MILLIMETERS. DIMENSIONS SHOWN IN [] ARE IN INCHES
 * MODELS 95 & 120 ARE AVAILABLE IN 2000mm [78.7"] HEIGHTS ONLY

Delta Model	H	A	B	C	D	U max.
30/30/150	1500 [59.1]	6620 [260.6]	1800 [70.1]		6094 [239.9]	17040 [670.9]
30/30/200	2000 [78.7]					
30/30/250	2500 [98.4]					
40/40/150	1500 [59.1]	8720 [343.3]	1800 [70.1]		8194 [322.6]	21240 [836.2]
40/40/200	2000 [78.7]					
40/40/250	2500 [98.4]					
50/50/150	1500 [59.1]	10520 [414.2]	2300 [90.6]		9994 [393.5]	25840 [1017.3]
50/50/200	2000 [78.7]					
50/50/250	2500 [98.4]					
60/60/150	1500 [59.1]	12320 [485.0]	2300 [90.6]		11794 [464.3]	29440 [1159.1]
60/60/200	2000 [78.7]					
60/60/250	2500 [98.4]					
70/70/150	1500 [59.1]	14920 [587.4]	2800 [110.2]		14394 [566.7]	35640 [1403.1]
70/70/200	2000 [78.7]					
70/70/250	2500 [98.4]					
85/85/150	1500 [59.1]	17320 [681.9]	2800 [110.2]	8660 [340.9]	16794 [661.2]	40440 [1592.1]
85/85/200	2000 [78.7]					
85/85/250	2500 [98.4]					
* 95/95/200	2000 [78.7]	19120 [752.8]	2800 [110.2]	9560 [376.4]	18594 [732.0]	44040 [1733.9]
* 120/120/200	2000 [78.7]	24978 [983.4]	3726 [146.7]	24978 [983.4]	24452 [962.7]	55756 [2195.1]

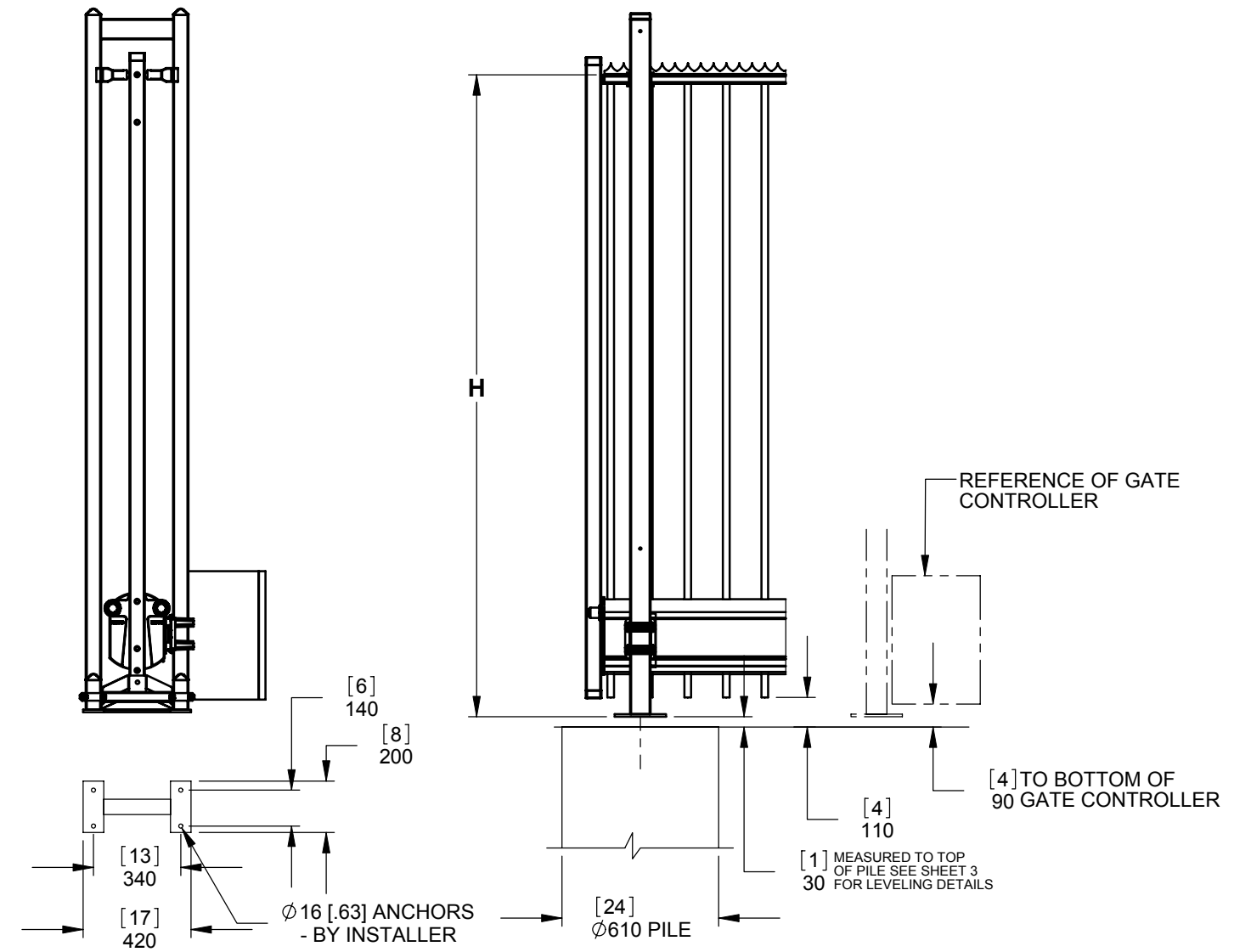

W WALLACE INTERNATIONAL

90 Lawson Crescent,
 Winnipeg, Manitoba, Canada R3P 2H8
 Phone: 1-866-300-1110
 Fax: 1-204-284-1868
 Web: www.wallaceintl.com

Description: **DOUBLE DELTA GATE**
STANDARD DIMENSIONS

Project / Customer Name: -

Finish: -

Drawing No. **DOUBLE-DELTA-07-13-11**

Date: -

Rev. -

Sheet: **1** of **5**

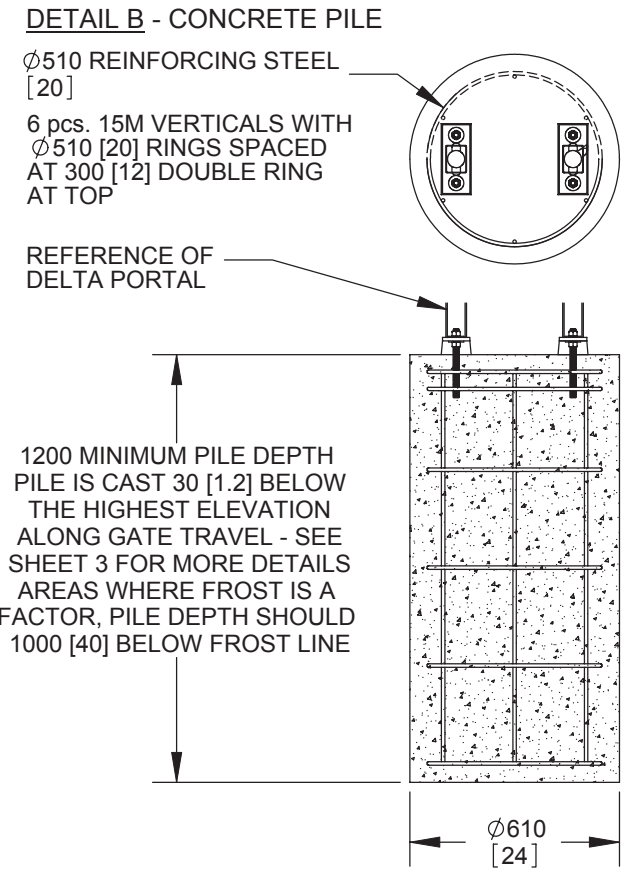
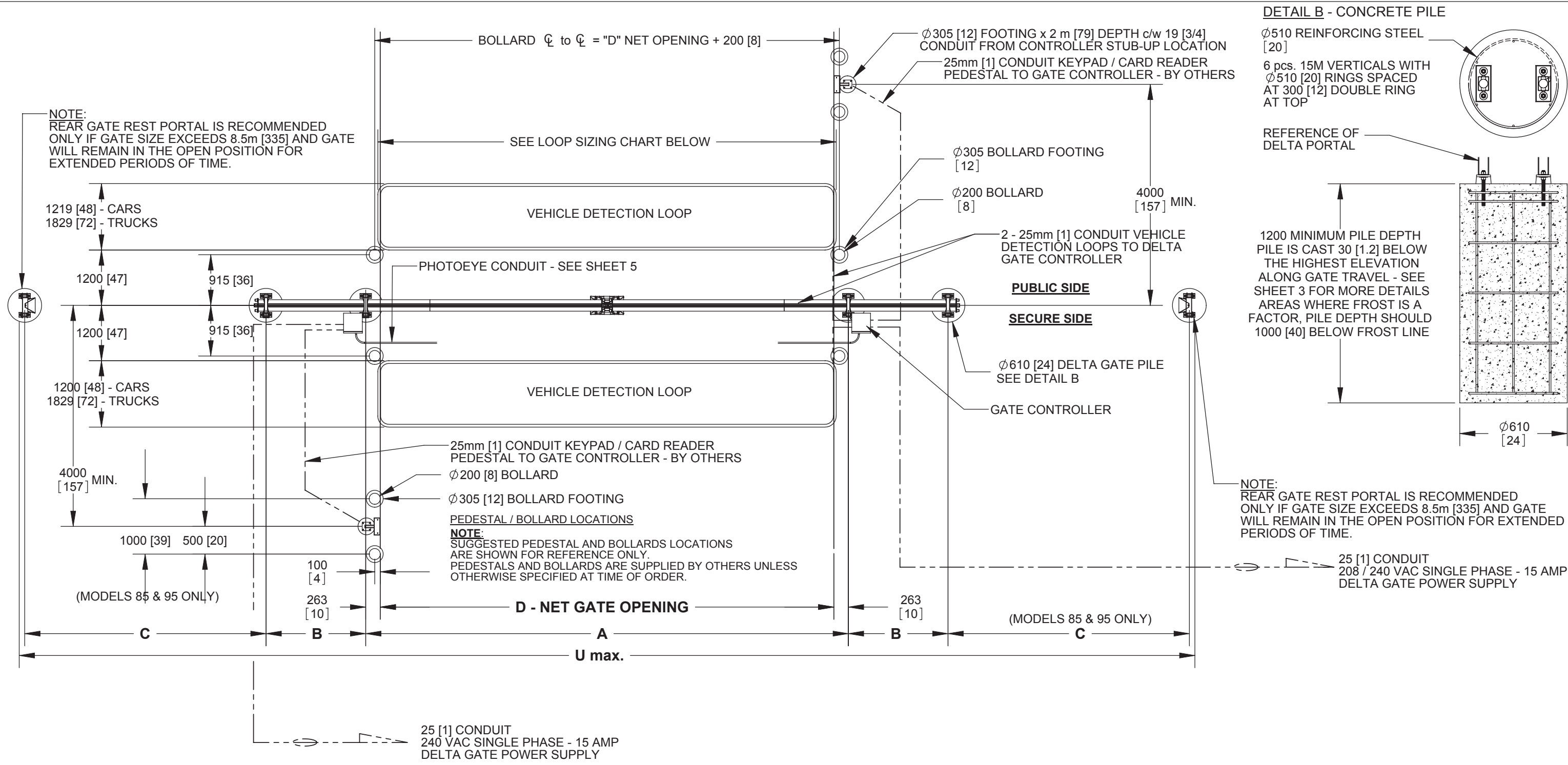

NOTE:
REAR GATE REST PORTAL IS RECOMMENDED ONLY IF GATE SIZE EXCEEDS 8.5m [335] AND GATE WILL REMAIN IN THE OPEN POSITION FOR EXTENDED PERIODS OF TIME.

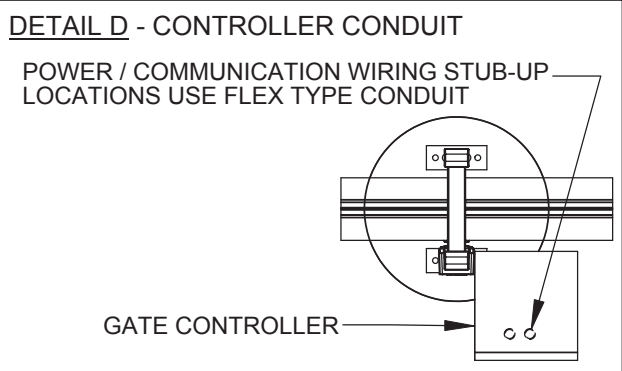

Delta Model	D - NET OPENING [IN]	LW - LOOP WIDTH [IN]
30/30	6094 [240]	4572 [180]
40/40	9194 [323]	6401 [252]
50/50	9994 [394]	8230 [324]
60/60	11794 [464]	10058 [396]
70/70	14394 [567]	12802 [504]
85/85	16794 [661]	15240 [600]
95/95	18594 [732]	17069 [672]
120/120	24452 [962.7]	22869 [900]

WALLACE INTERNATIONAL

90 Lowson Crescent,
Winnipeg, Manitoba, Canada R3P 2H8
Phone: 1-866-300-1110
Fax: 1-204-284-1868
Web: www.wallaceintl.com

Description: **DOUBLE DELTA GATE STANDARD DIMENSIONS**
SUGGESTED LOOP AND PEDESTAL LOCATIONS

Project / Customer Name:

Finish: _____ Date: _____

Drawing No. **DOUBLE-DELTA-07-13-11** Rev. _____ Sheet: **2 of 5**

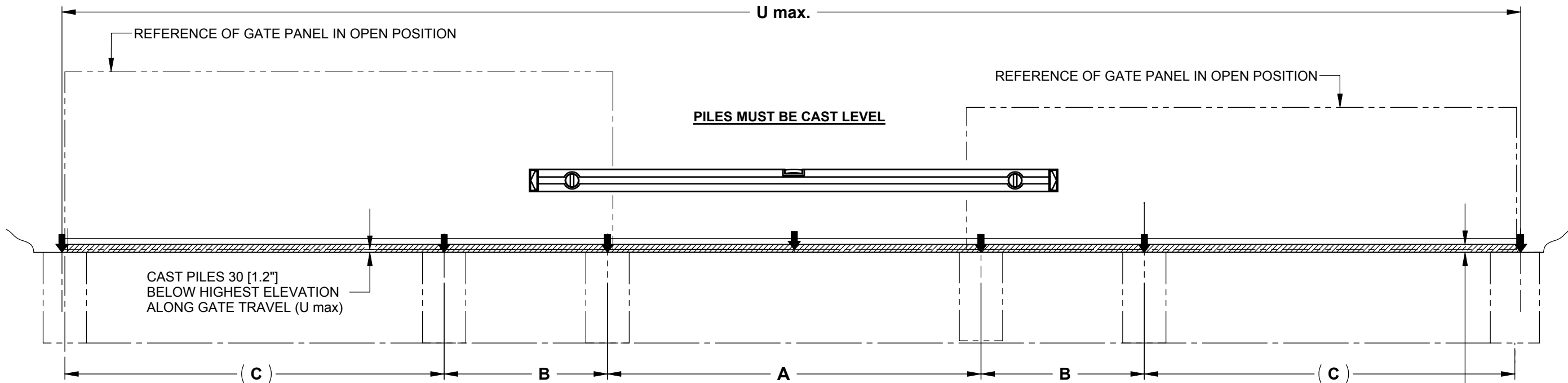

***** IMPORTANT NOTE *****
 130 [5"] MEASURED FROM TOP OF PILE. AREA ALONG GATE PANEL TRAVEL MUST BE CLEAR OF OBSTRUCTIONS TO ALLOW PROPER OPERATION OF GATE. GROUND COVER SHOULD BE RESILIENT ENOUGH TO ALLOW CLEARING OF MUD, ICE, SNOW OR DERIS BUILD UP.

SURFACE SHOULD BE SUITABLE FOR SECURING CENTER CATCH SHOE USING 16 [5/8"] ANCHORS

AREA ADJACENT TO GATE SHOULD BE CLEAR OF OBSTRUCTIONS ALLOWING REMOVAL OF ANY MUD , ICE, SNOW OR DEBRIS BUILD UP THAT MAY OCCUR.

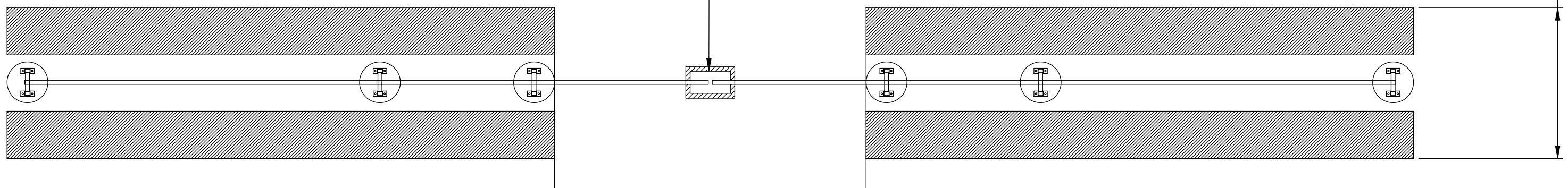

 WALLACE INTERNATIONAL 90 Lowson Crescent, Winnipeg, Manitoba, Canada R3P 2H8 Phone: 1-866-300-1110 Fax: 1-204-284-1868 Web: www.wallaceintl.com	Description:		INSTALLATION NOTES	
			DOUBLE DELTA SLIDE GATE	
	Project / Customer Name:			
	-			
Finish:		Date:		
-				
Drawing No.		Rev.	Sheet:	
DOUBLE-DELTA-07-13-11			3 of 5	

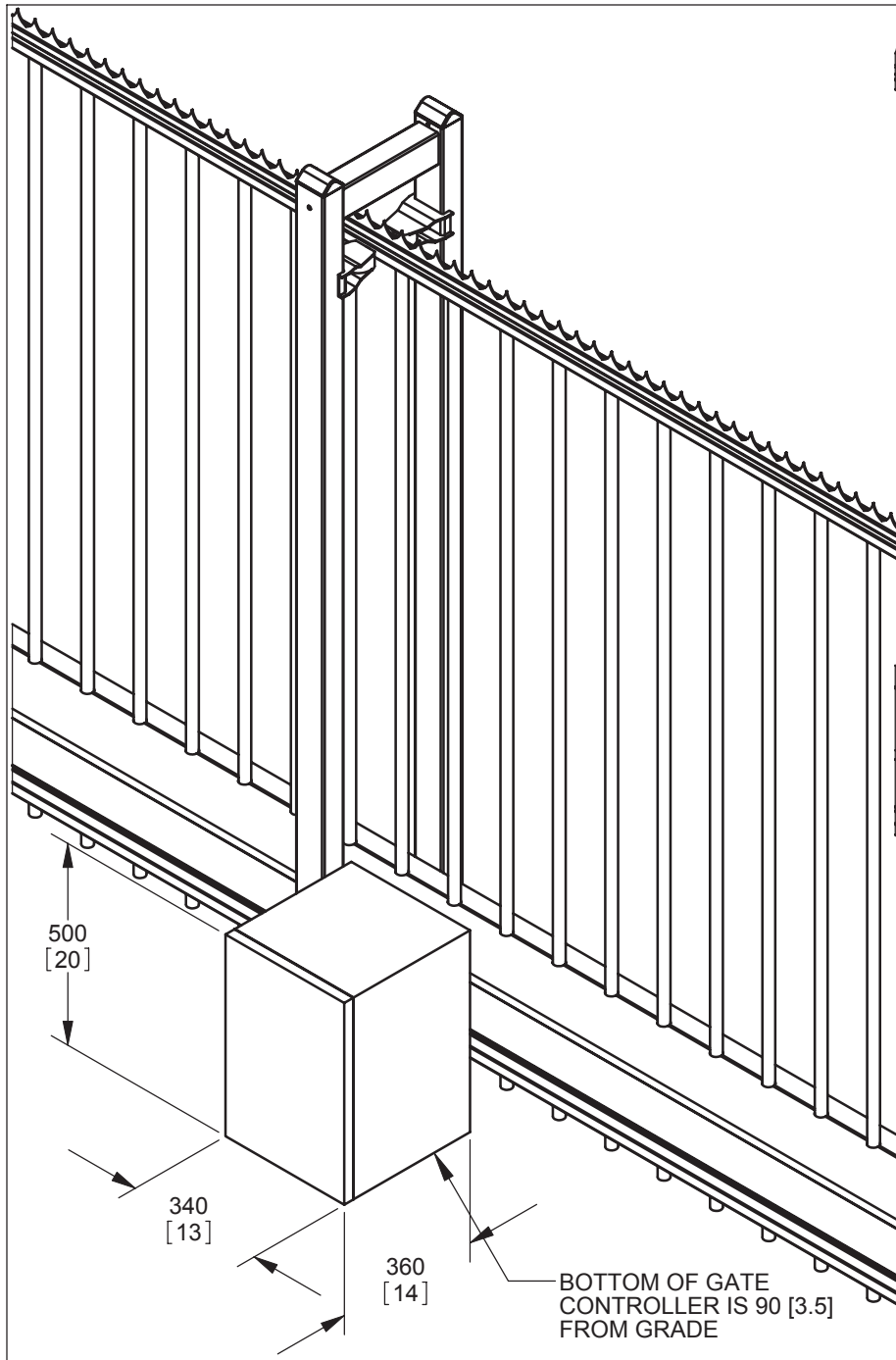

NOTE:
GATE CONTROLLER IS LOCATED ON THE SECURE SIDE OF GATE.
INCOMING POWER REQUIREMENTS, 240 VAC SINGLE PHASE, 15A

DETAIL 4-1 - GATE CONTROLLER DIMENSIONS

DETAIL 4-4 - OPTIONAL REAR REST SHOE

NOTE:
REAR GATE REST SHOE IS RECOMMENDED ONLY IF GATE SIZE IS EQUAL TO OR GREATER THAN 8.5M [335] AND THE GATE WILL REMAIN IN THE OPEN POSITION FOR EXTENDED PERIODS OF TIME

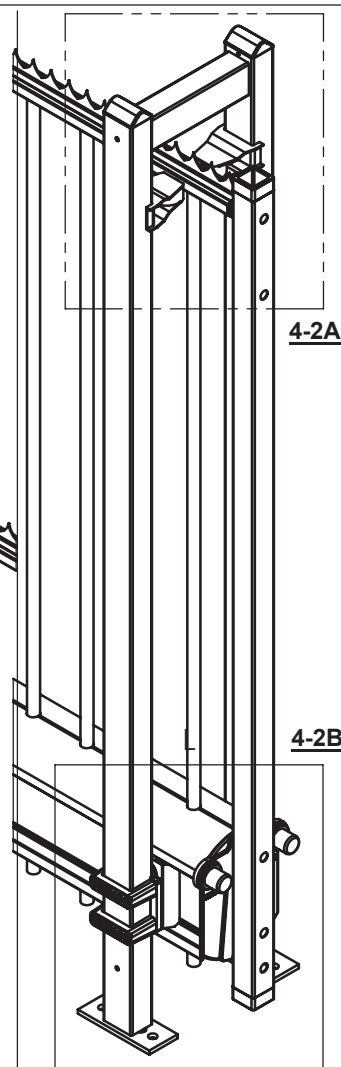
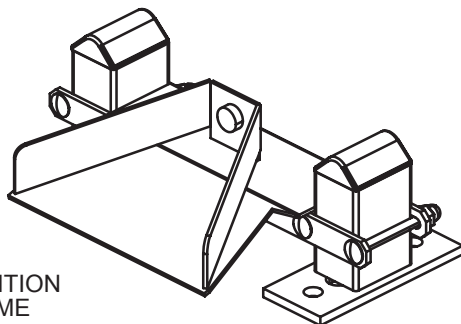

DETAIL 4-2 - PANEL ROLLERS

MAIN BEAM ROLLER SET (X2)

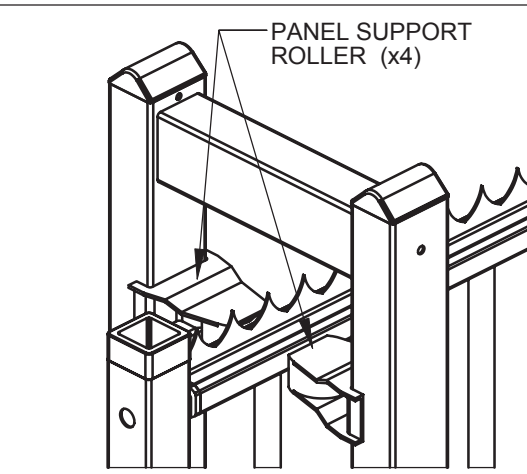

DETAIL 4-2A - UPPER PANEL SUPPORT ROLLER

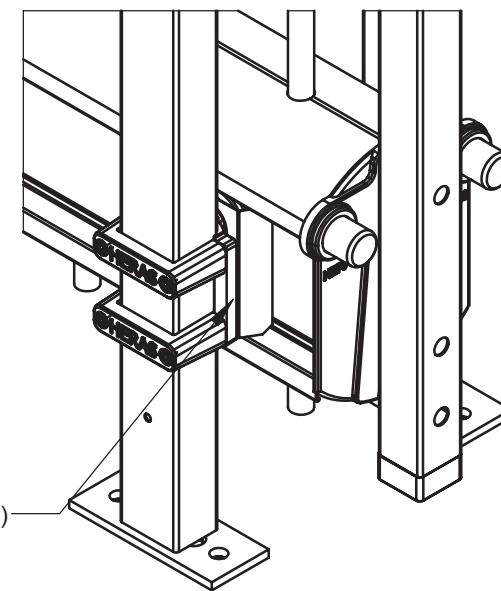

DETAIL 4-2B - MAIN BEAM ROLLER SET

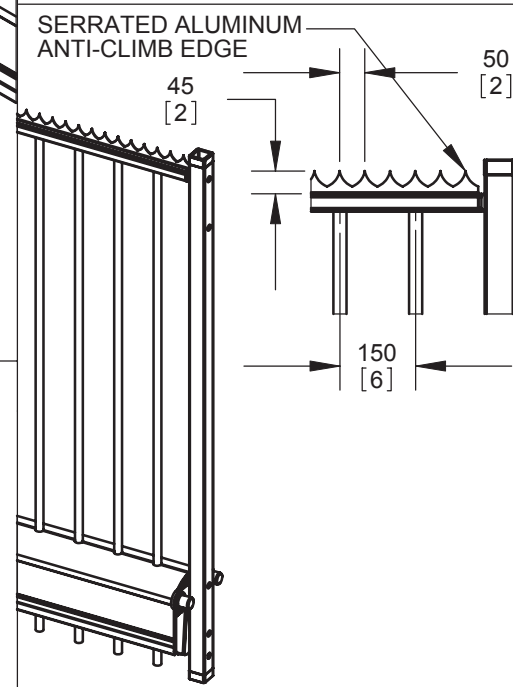

DETAIL 4-5A - HERECLES PANEL INFILL

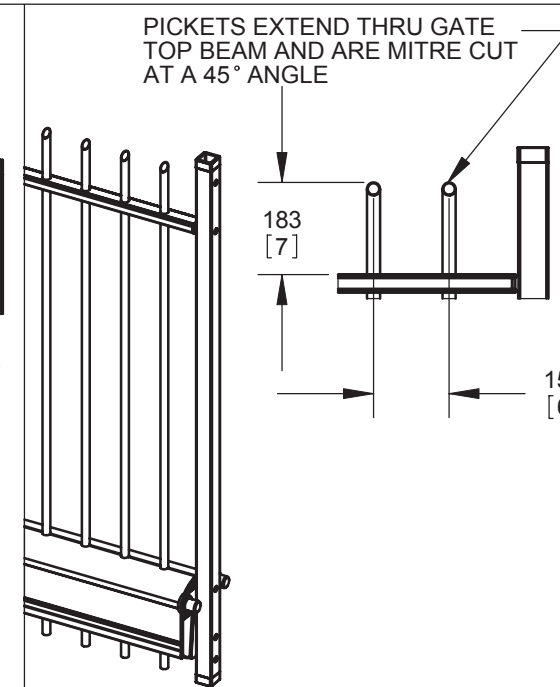

DETAIL 4-5B - ATLAS PANEL INFILL

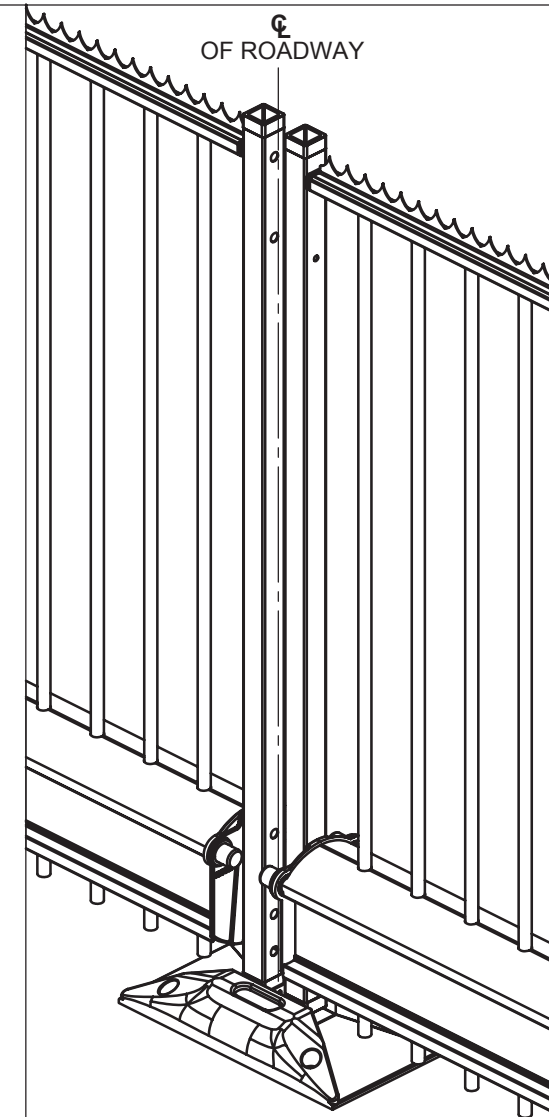

DETAIL 4-3 - CENTER CATCH SHOE DETAILS

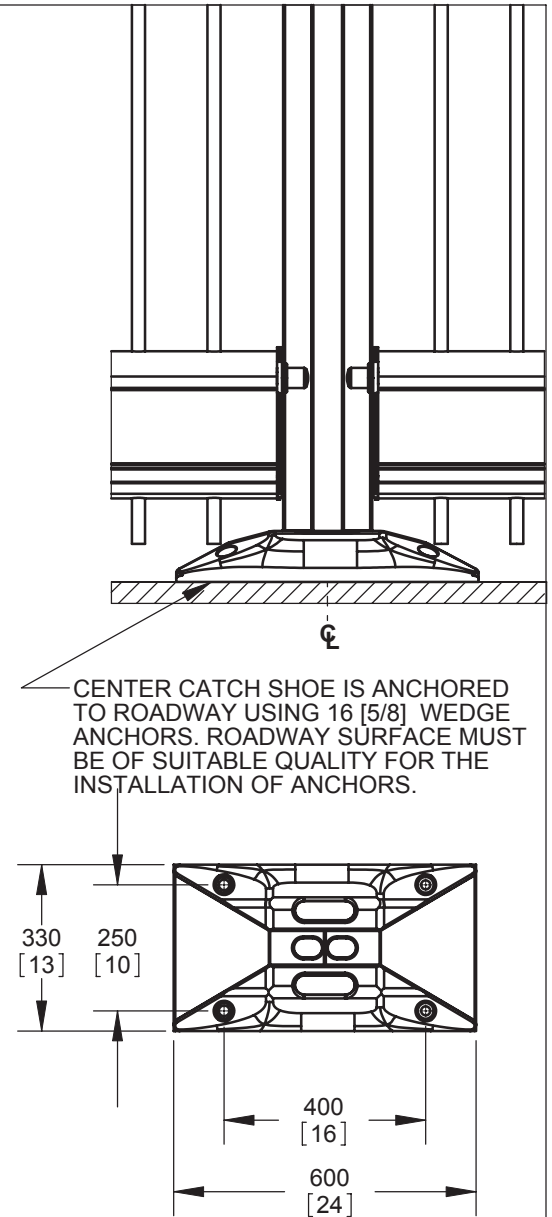

CENTER CATCH SHOE IS ANCHORED TO ROADWAY USING 16 [5/8] WEDGE ANCHORS. ROADWAY SURFACE MUST BE OF SUITABLE QUALITY FOR THE INSTALLATION OF ANCHORS.

NOTES:

GATE FINISH:

- HOT DIPPED GALVANIZED FINISH FOR ALL STEEL COMPONENTS
- ALUMINUM GATE BEAMS - CLEAR ANODIZED FINISH

OPTIONAL:

POWDER COAT PAINT FINISH AVAILABLE - RAL COLOR NUMBER MUST BE SUPPLIED AT TIME OF ORDER.



90 Lowson Crescent,
Winnipeg, Manitoba, Canada R3P 2H8
Phone: 1-866-300-1110
Fax: 1-204-284-1868
Web: www.wallaceintl.com

Description:		DOUBLE DELTA GATE STANDARD / OPTIONAL COMPONENTS	
Project / Customer Name:			
Finish:	-	Date:	
Drawing No.	DOUBLE-DELTA-07-13-11	Rev.	Sheet:
			4 of 5

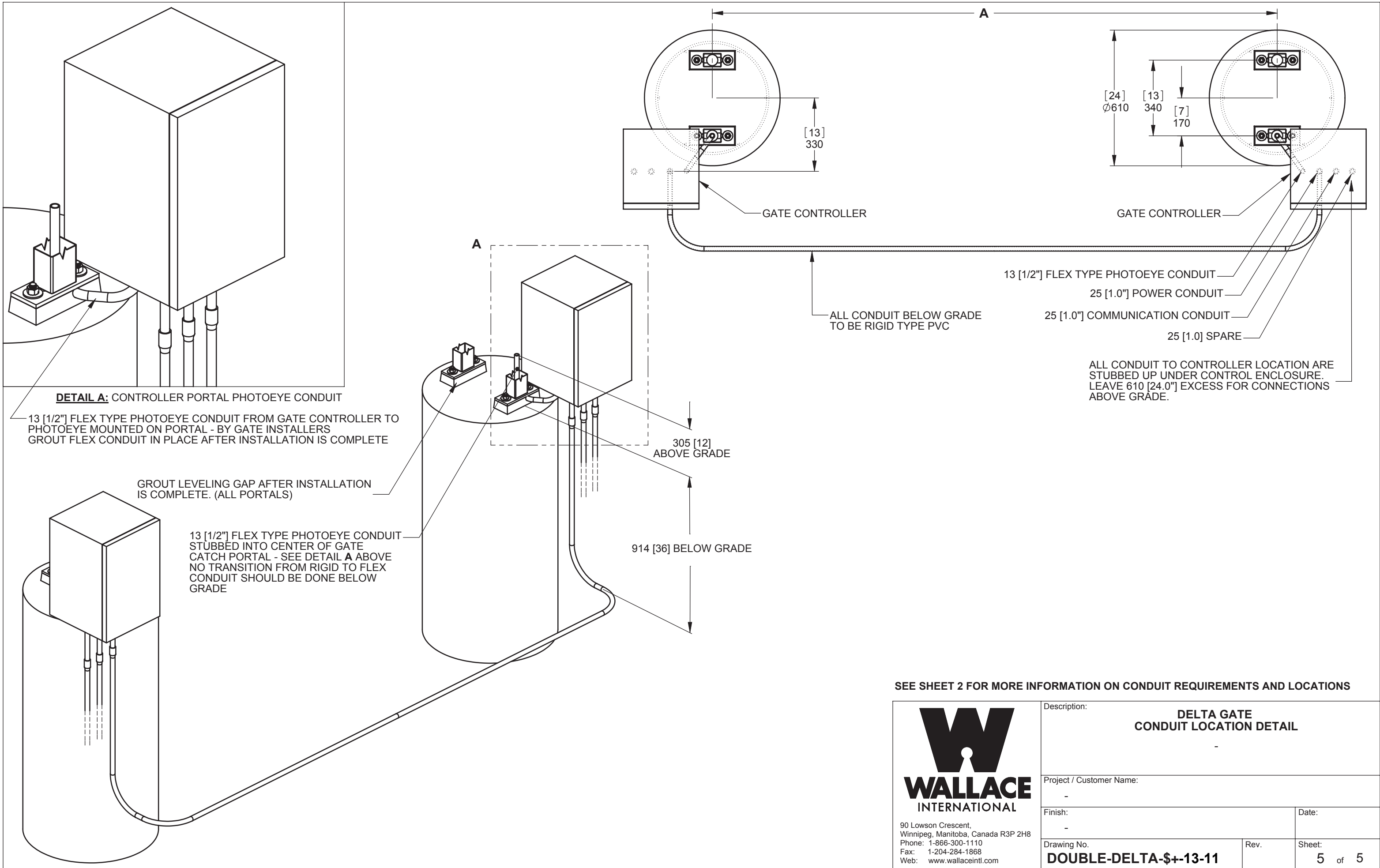

SEE SHEET 2 FOR MORE INFORMATION ON CONDUIT REQUIREMENTS AND LOCATIONS

 <p>90 Lawson Crescent, Winnipeg, Manitoba, Canada R3P 2H8 Phone: 1-866-300-1110 Fax: 1-204-284-1868 Web: www.wallaceintl.com</p>	Description:		DELTA GATE CONDUIT LOCATION DETAIL	
	Project / Customer Name:			
	Finish:		Date:	
	Drawing No.		Rev.	Sheet:
DOUBLE-DELTA-\pm-13-11			5 of 5	