

USING THE BREAK-OFF TOOL, BEND CLIP BACK AND FORTH TOWARD OPPOSITE FACE OF FRAME. DO NOT BEND PAST THE OUTSIDE FACE TO AVOID DEFORMING THE FACE.

NOTE: USING PLIERS TO BREAK OFF THE CORNER CLIP MAY RESULT IN DAMAGE TO THE FACE OF FRAME

2 Masonry KD 4" Face Head FRAME TECHNICAL DATA

April 1, 2002

ASSA ABLOY, the global leader
in door opening solutions

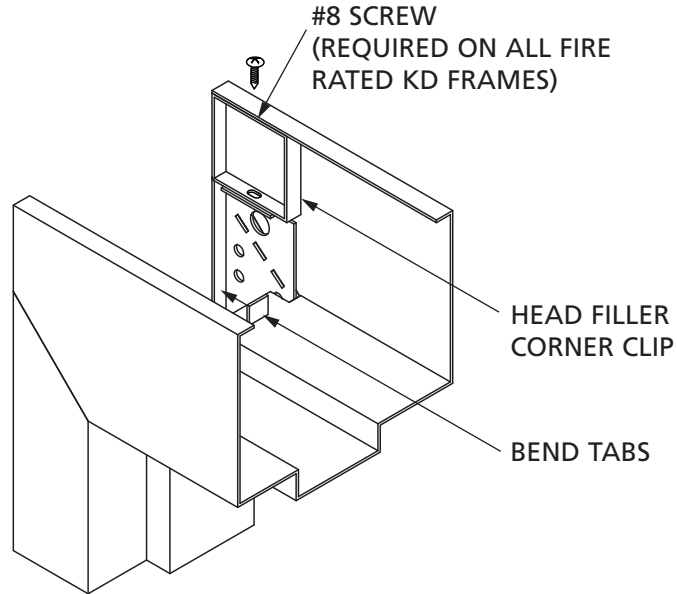

Masonry KD Double Egress Frame

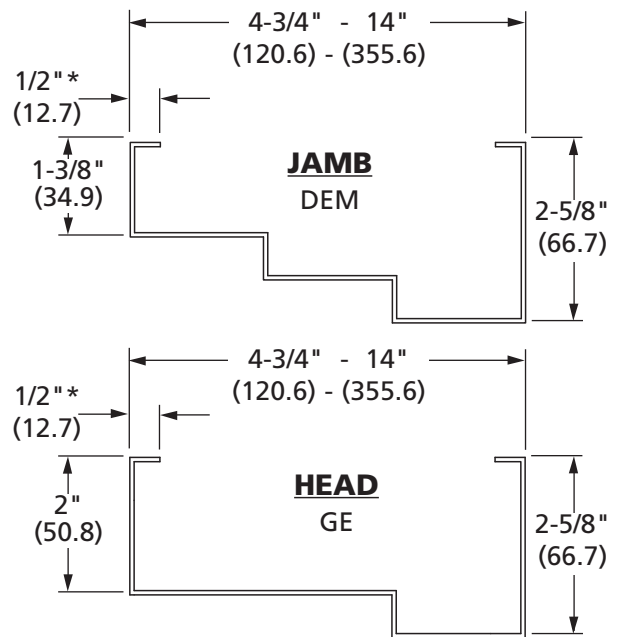
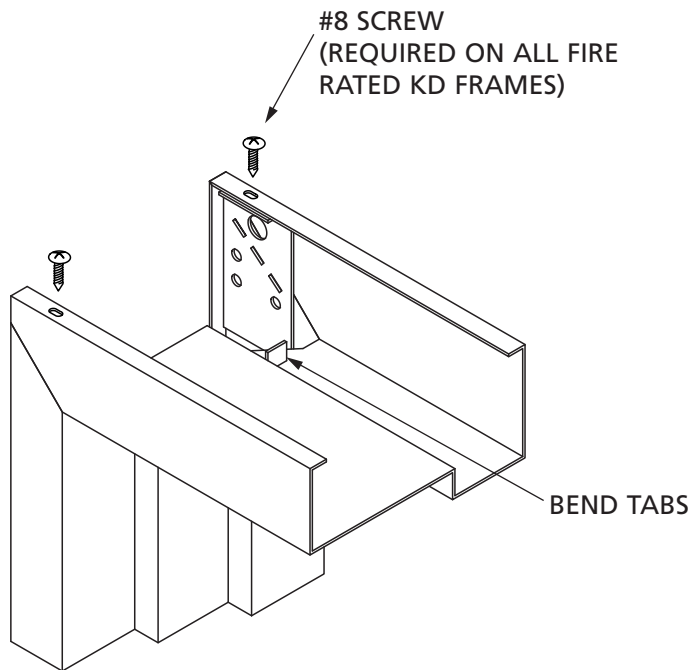

* 5-3/4" (146.1) JAMB DEPTH HAS 7/16" (11.1) RETURN

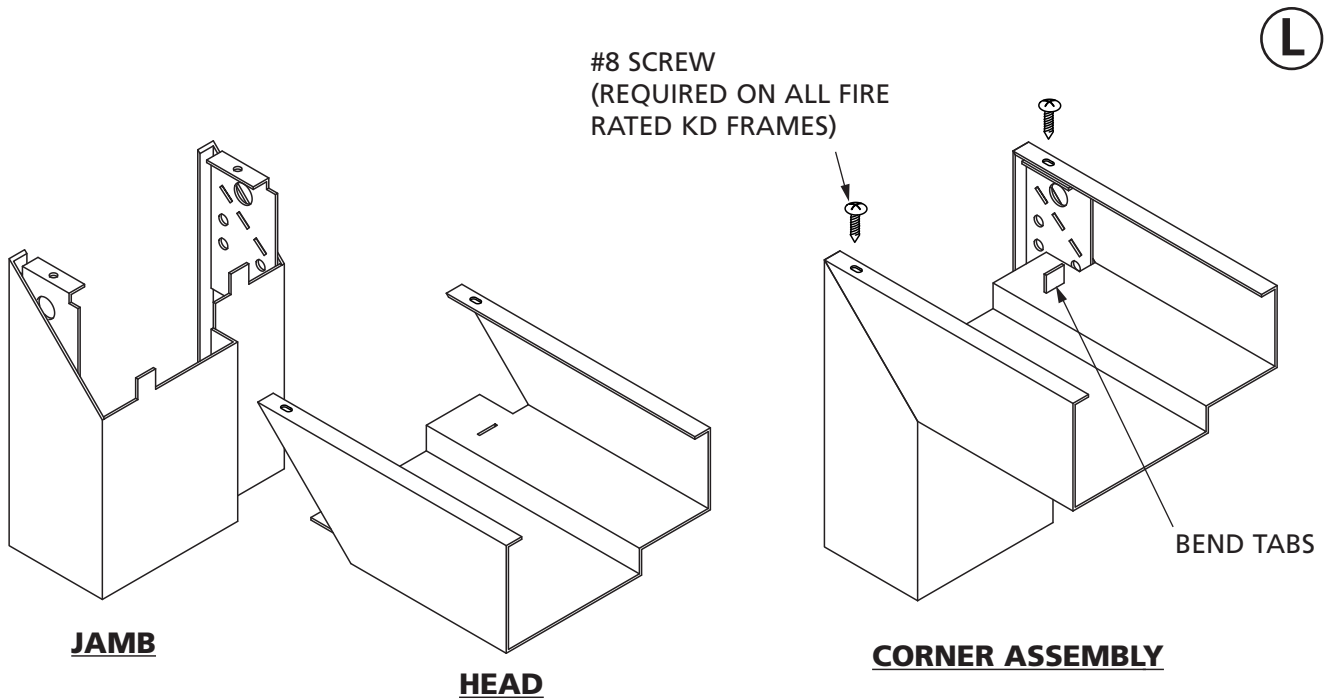

Masonry KD 2" Face Flush Frame Unequal Rabbet

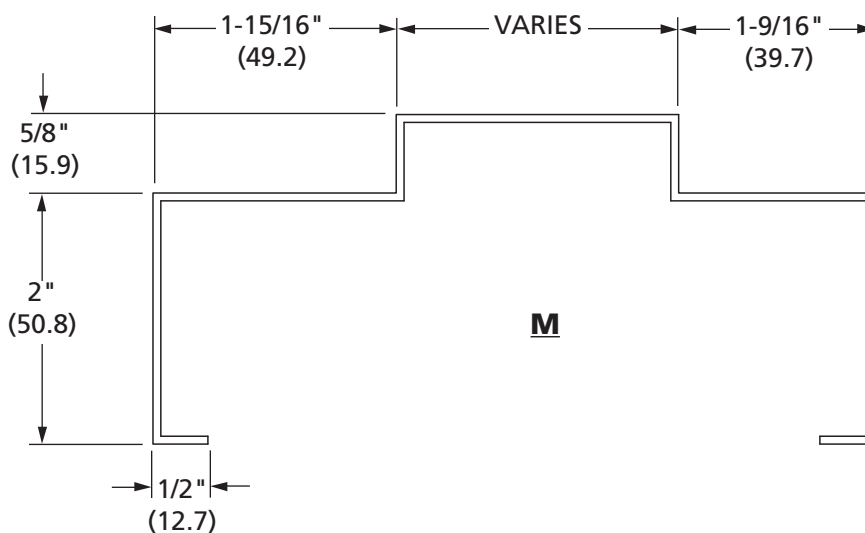

KD "M" TYPE FLUSH
GAUGE - 18 GA. (1.2), 16 GA. (1.4), 14 GA. (1.9)
VARIABLE SOFFIT
JAMB DEPTH 4-1/2" (114.3) THRU 14" (355.6) (1/8"(3.2) INCREMENTS)
AVAILABLE WITH 4" (101.6) FACE HEADS
NOTE: 5-3/4" (146.1) JAMB DEPTH STANDARD WITH 7/16" (11.1) RETURNS
TO PROVIDE 4-7/8" (123.8) THROAT OPENING

FRAME TECHNICAL DATA

April 1, 2002

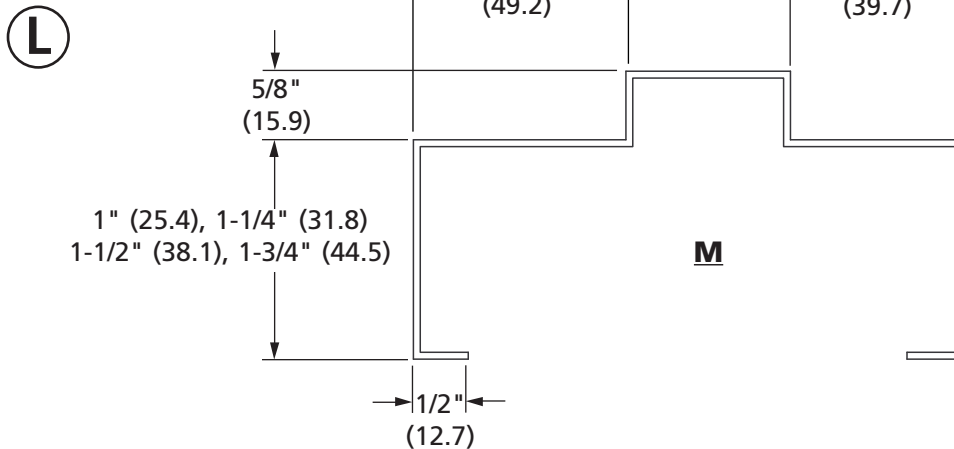

KD "M" TYPE FLUSH

GAUGE - 18 GA. (1.2), 16 GA. (1.4), 14 GA. (1.9)

VARIABLE SOFFIT

JAMB DEPTH 4-1/2" (114.3) THRU 14" (355.6) (1/8" (3.2) INCREMENTS)

NOT AVAILABLE WITH 4" (101.6) FACE HEADS

NOTE: WHEN CCW MATERIAL IS USED IN CONJUNCTION WITH ABOVE, COORDINATE RABBET AND FACE DIMENSIONS 5-3/4" (146.1) JAMB DEPTH STANDARD WITH 7/16" (11.1) RETURNS TO PROVIDE 4-7/8" (123.8) THROAT OPENING.

Masonry Flush KD Frame Equal Rabbet

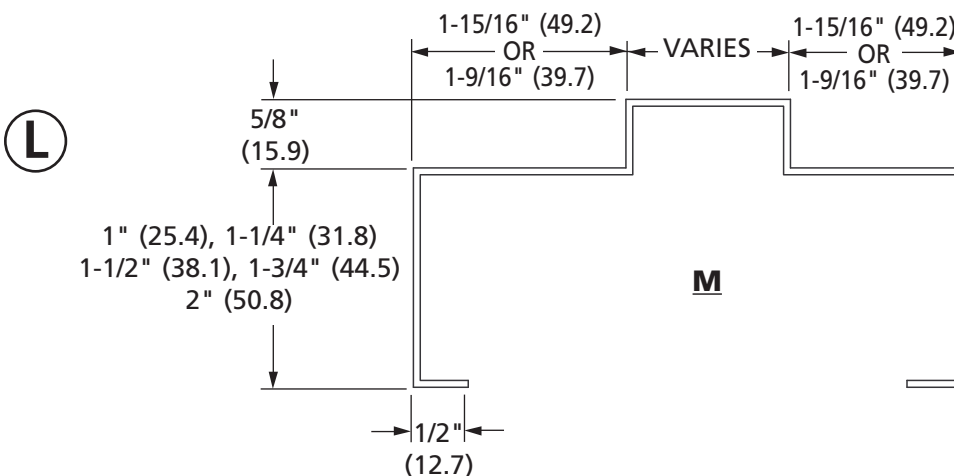

KD "M" TYPE FLUSH

GAUGE - 18 GA. (1.2), 16 GA. (1.4), 14 GA. (1.9)

VARIABLE SOFFIT

JAMB DEPTH 4-7/8" (114.3) THRU 14" (355.6) (1/8" (3.2) INCREMENTS)

AVAILABLE WITH 4" (101.6) FACE HEADS WITH 2" FACE JAMBS ONLY

NOTE: WHEN CCW MATERIAL IS USED IN CONJUNCTION WITH ABOVE, COORDINATE RABBET AND FACE DIMENSIONS. 5-3/4" (146.1) JAMB DEPTH STANDARD WITH 7/16" (11.1) RETURNS TO PROVIDE 4-7/8" (123.8) THROAT OPENING.

April 1, 2002

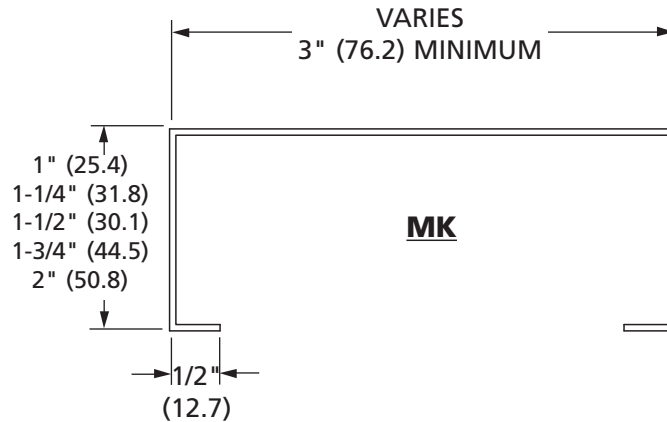

KD "MK" TYPE FLUSH

GAUGE - 18 GA. (1.2), 16 GA. (1.4), 14 GA. (1.9)

JAMB DEPTH 3" (76.2) THRU 14" (355.6) (1/8" (3.2) INCREMENTS)

NOTE: AVAILABLE WITH 4" (101.6) FACE HEAD WITH 4-1/2" (114.3) MINIMUM JAMB DEPTH
5-3/4" (146.1) JAMB DEPTH STANDARD WITH 7/16" (11.1) RETURNS
TO PROVIDE 4-7/8" (123.8) THROAT OPENING.

* TOTAL DOOR ONLY MAY BE LABELED

Masonry Flush KD "G" Profile Frame

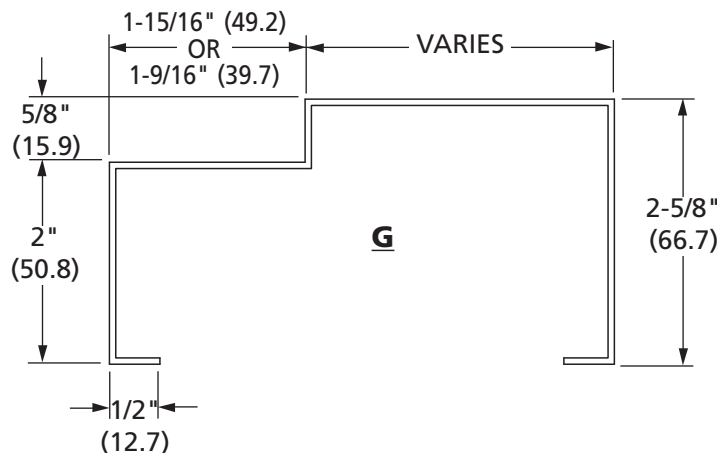

KD "G" TYPE FLUSH

GAUGE - 18 GA. (1.2), 16 GA. (1.4), 14 GA. (1.9)

JAMB DEPTH 3" (76.2) THRU 14" (355.6) (1/8" (3.2) INCREMENTS)

MIN. 4" JAMB DEPTH FOR LABELED FRAME WITH 1-15/16" RABBET AND
3-1/4" JAMB DEPTH FOR 1-9/16" RABBET.

NOTE: 2" (50.8) AND 2-5/8" (66.7) FACE ON JAMBS
AVAILABLE WITH 4" (101.6) FACE HEAD WITH 4-1/2" (114.3) MINIMUM JAMB DEPTH.
5-3/4" (146.1) JAMB DEPTH STANDARD WITH 7/16" (11.1) RETURNS
TO PROVIDE 4-7/8" (123.8) THROAT OPENING.