

# 10 847 Security Door Construction DOOR TECHNICAL DATA

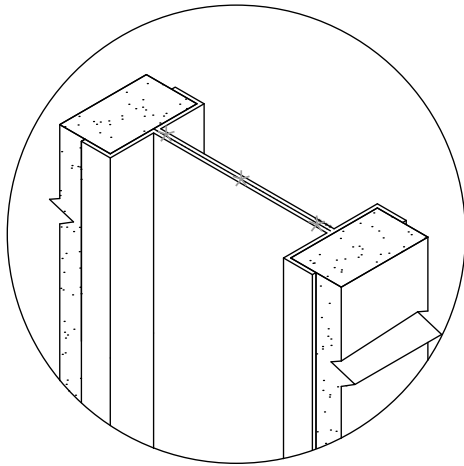

April 1, 2002

ASSA ABLOY, the global leader  
in door opening solutions



RIBS WELDED TOGETHER AT ENDS

RIBS, SPOT WELDED TO EACH SKIN AT  
4" (102) MAX. SPACING 18 GA. (1.2)  
AND WELDED FULL WIDTH ON ENDS.

FACE SHEETS (STANDARD)  
14 GA. (1.9)

