

ASSA ABLOY, the global leader  
in door opening solutions

July, 2009

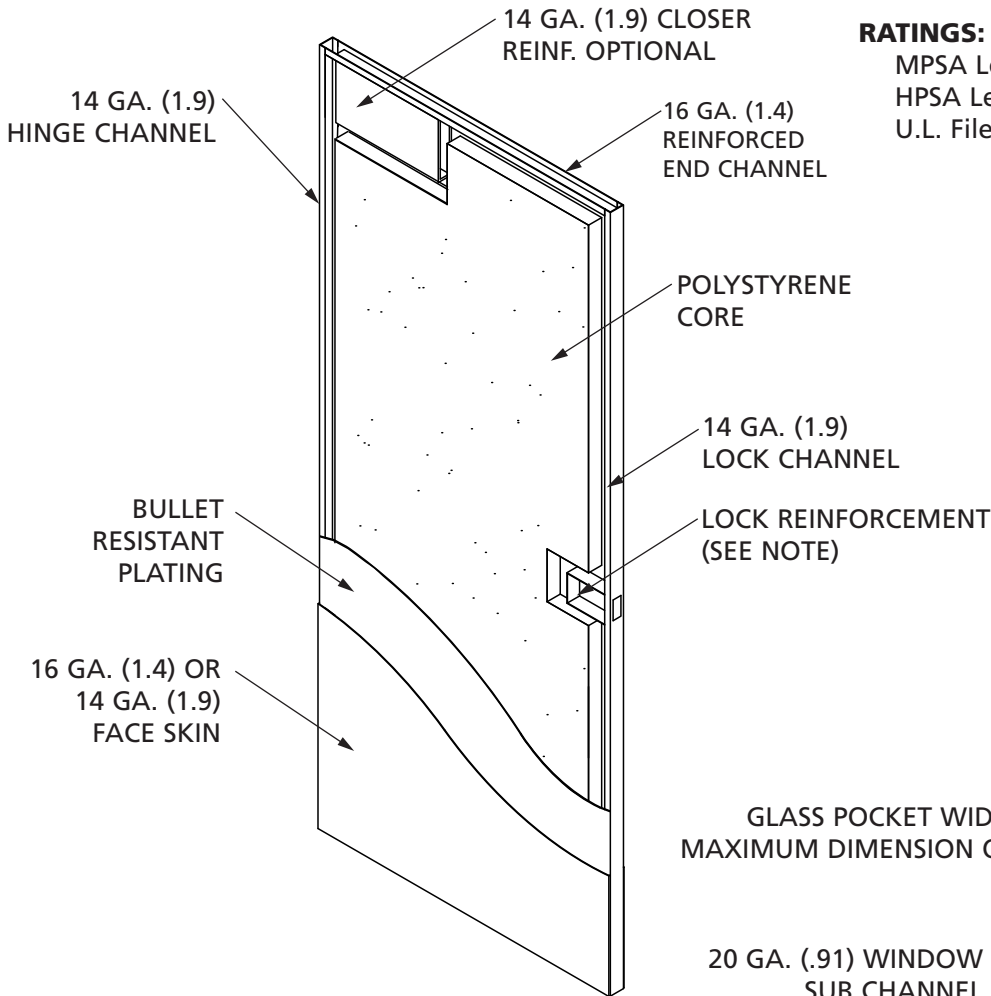

**NOTE:** Door and frame must be furnished as a complete assembly with factory welded M12 series frame.  
*Tested in accordance and complies with U.L. test standard 752 "Bullet Resistant Equipment"*



**RATINGS:**

MPSA Level 1 (Medium power small arms)  
HPSA Level 2 (High power small arms)  
U.L. File #5869

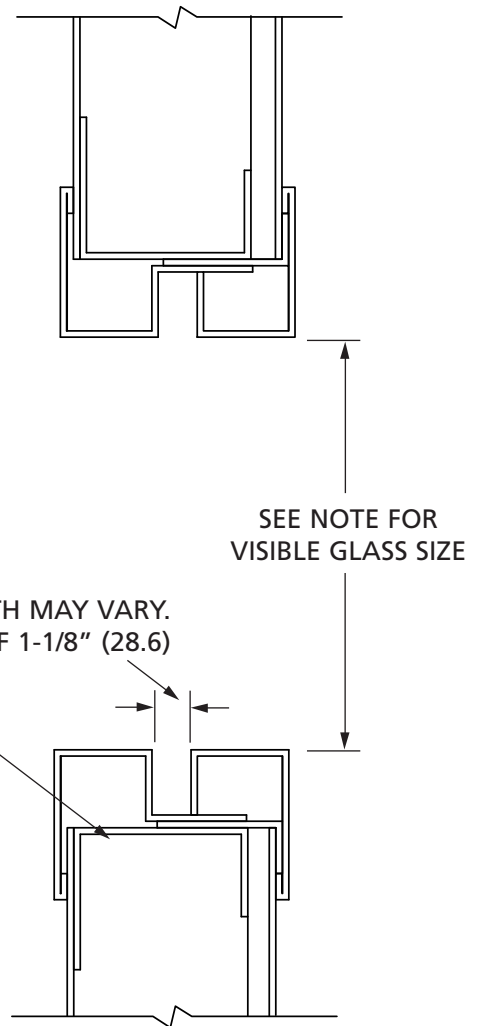

**NOTES:**

**MAXIMUM SIZE:**

4'0" (1219.2) Wide X 10'0" (3048) High- SINGLE OPENING ONLY!

**HARDWARE:**

CONTACT FACTORY FOR HARDWARE APPROVED FOR USE WITH THIS ASSEMBLY.

**VISION PANELS:**

FV3 = Actual glass size is 12" (304.8) x 12" (304.8)  
Visible opening is 10-13/16" (274.6) X 10-13/16" (274.6)

