

Frigidaire

Ventilation

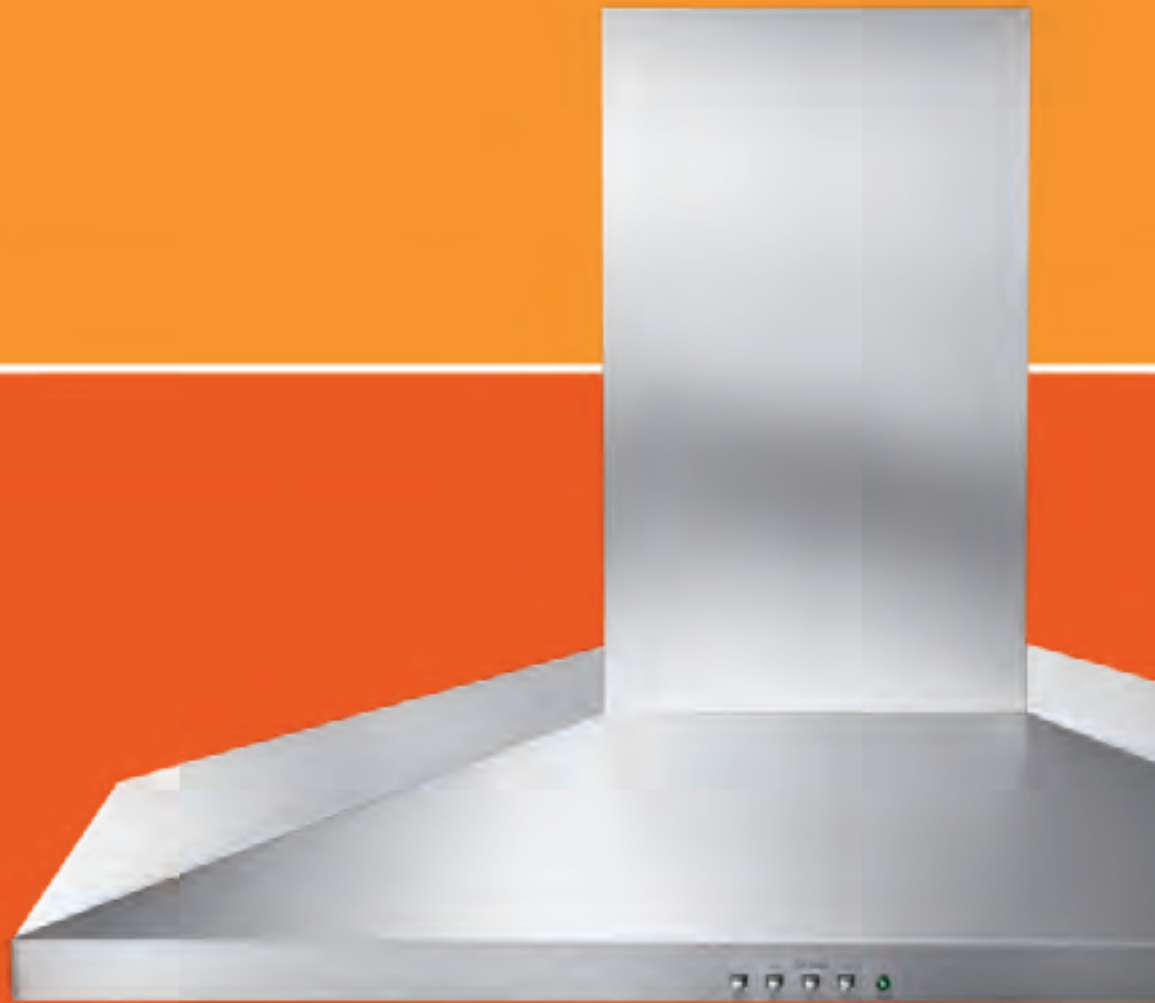

Frigidaire

Fresh ideas.

When it comes to keeping your kitchen free of cooking odors, no one offers more power or more choices than Frigidaire®.

So you've come to expect a Frigidaire® ventilation system that's as stylish as it is efficient and as powerful as it is flexible.

You count on ducting options that vent through the wall, through the roof or just recirculate and freshen kitchen air.

You anticipate a variety of choices from wall mount to island to overhead to downdraft in stainless steel, black, white or bisque.

And, from the economical 24" overhead to the 36" dual centrifugal island, you demand the ventilation system with exactly the right capacity for your kitchen.

You expect all this from Frigidaire®... and we deliver.

Ventilation System Features



Halogen Lighting
Even, natural lighting provides abundant illumination to enhance your cooking experience.



Dishwasher Safe Filters
Filters remove even the most persistent cooking odors and clean up easily by cycling through your dishwasher.



Electromechanical Pushbutton Controls
Conveniently located and easy to understand, the pushbutton controls are easy to clean and add style to your range hood.



Auto-Start
As the cooking surface temperature increases, the Heat Sensor automatically turns on the blower fan.



Nonstick Coating
The nonstick surface of the underside of the range hood allows for quick and easy removal of grease and soot.

Professional Series®

PL36WC50E C 36"

- Wall-Mount Installation
- 500 Cubic Feet per Minute External Exhaust
- Centrifugal Blower Fan System with 3 Speed Settings: Low, Medium, High
- Electromechanical Push Button Controls
- Dual Halogen Lighting
- Dishwasher Safe Aluminum Filters
- Convertible to Ductless

Also Available:

PL36PC50E C 36"

(Available with same features as PL36WC50EC)

- Island Installation



Professional Series®

PL42WC51E C 42"

PL36WC51E C 36"

PL30WC51E C 30"

- Wall-Mount Installation
- 500 Cubic Feet per Minute External Exhaust (Vertical)
- Centrifugal Blower Fan System with 3 Speed Settings: Low, Medium, High
- Electromechanical Push Button Controls
- Dual Halogen Lighting
- Dishwasher Safe Aluminum Filters
- Convertible to Ductless



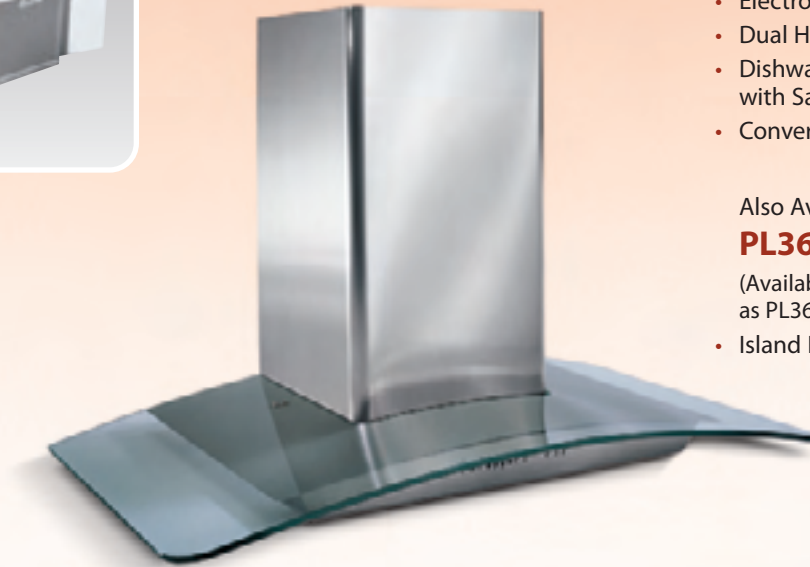
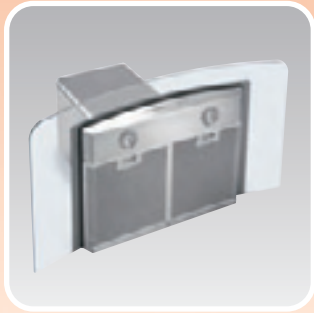

Professional Series® PL36WC40E C 36"

- Wall-Mount Installation
- 400 Cubic Feet per Minute External Exhaust
- Centrifugal Blower Fan System with 4 Speed Settings: Low, Medium, High, Intensive
- Electronic Controls
- Dual Halogen Lighting
- Dishwasher Safe Aluminum Filters with Saturation LED Indicator
- Convertible to Ductless

Also Available:

PL36PC40E C 36"

(Available with same features as PL36WC40EC)

- Island Installation

Professional Series® PL36DD50E C 36" PL30DD50E C 30"



- 30" and 36" Rear-Mount Downdraft Vent
- 500 CFM Ducted Ventilation System
- Mounts Behind Cooktop
- Push Button Auto Raise/Lower
- Infinite Speed Blower Control
- 3 Position Discharge
- Dishwasher Safe Aluminum Filters
- Top Trim Kits Available in Black and White

Frigidaire



Professional Series®

PL36WC41E C 36"

PL30WC41E C 30"

- Overhead Installation
- 400 Cubic Feet per Minute External Exhaust (Vertical or Horizontal)
- Centrifugal Blower Fan System
- 3-Speed Fan
- Auto-Start Heat Sensing System
- Nonstick Coating
- 3 Levels of Halogen Light Settings
- Dishwasher Safe Aluminum Filters
- 4-Way Convertible



Gallery Series®

GL36WC41E S/B 36"

GL30WC41E S/B 30"

- Overhead Installation
- 400 Cubic Feet per Minute External Exhaust (Vertical or Horizontal)
- Centrifugal Blower Fan System
- 3-Speed Fan
- Auto-Start Heat Sensing System
- Nonstick Coating
- 3 Levels of Halogen Light Settings
- Dishwasher Safe Aluminum Filters
- 4-Way Convertible



Frigidaire®

F42WC19E S/B/Q 42"

(Factory-direct only)

F36WC19E C/S/B/Q 36"

F30WC19E C/S/B/Q 30"

- Overhead Installation
- 190 Cubic Feet per Minute External Exhaust (7" Round - Vertical only)
- 160 Cubic Feet per Minute External Exhaust (3-1/4" x 10" Horizontal and Vertical only)
- Fan Blower with 2 Speeds
- Rocker Switch
- Cooking Surface Light
- Dishwasher Safe Filter
- 4-Way Convertible



Frigidaire®

F30WV16E C/S/B 30"

- Overhead Installation
- 160 Cubic Feet per Minute External Exhaust (Vertical or Horizontal)
- Fan Blower with 2 Speeds
- Rocker Switch
- Cooking Surface Light
- Dishwasher Safe Filter



Frigidaire®

F30WR01E C/S/B/Q 30"

F24WR01E S 24"

(Factory-direct only)

- Overhead Installation
- Re-Circulating Exhaust
- Fan Blower with 2 Speeds
- Rocker Switch
- Cooking Surface Light
- Removable/Replaceable Filters

Frigidaire

Accessories

For model-specific part numbers, refer to charts on pages 10-11.

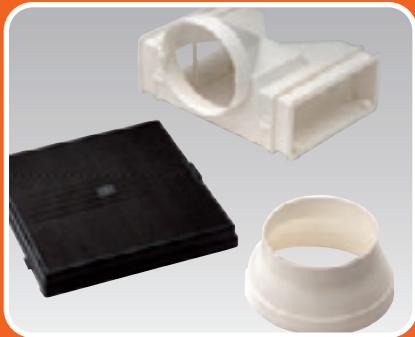

Duct-Free Kit

When ducting a ventilation system to the outdoors is impractical, the Duct-Free Kit easily converts your range hood to a recirculating air purification system.



Flue Extension

Extension allows you to easily and quickly adapt your ventilation system to a vaulted ceiling application

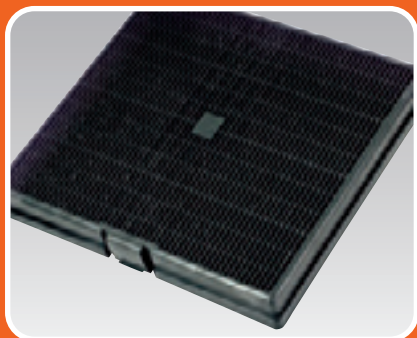

Charcoal Filter

For the ultimate in air purification, the Charcoal Filter removes cooking odors that conventional filters cannot.



Top Trim Kit

Color coordinate your Downdraft Ventilation System with a black or white trim kit.



16-Oz. Stainless Steel Appliance Cleaner

Nonabrasive stainless steel cleaner provides superior protection and guards against smudges. Spray-trigger is designed to work great on larger surfaces to cover more area.

5304433275



Kitchen Grips

These revolutionary oven mitts and potholders provide protection against dangerous scalds or burns. Constructed of a new stain-free material that is impermeable to liquids and heat-resistant up to 500° F. Mitt is usable on left or right hand.

GMBLUEC - Blue

GMREDEC - Red

GMGRNEC - Green

GMBLKEC - Black

GAS COOKTOP DIMENSIONS

Models	Exterior Dimensions			Cutout Dimensions				F-Clearance Required U/C	Gas Inlet Location
	A-Width	B-Depth	C-Height	D-Width		E-Depth			
				Minimum	Maximum	Minimum	Maximum		
36" Cooktops									
PLGC36S9E	36"	21-1/2"	2-3/4"	33-7/8"	34-1/4"	19-1/8"	19-3/4"	8"	Right Rear
GLGC36S9E	36"	21-1/2"	2-3/4"	33-7/8"	34-1/4"	19-1/8"	19-3/4"	8"	Right Rear
GLGC36S8E	36"	21-1/2"	2-3/4"	32-3/4"	33"	19"	19-3/8"	5"	Right Rear
FGC36S6A	36"	18"	3-1/2"	34-1/4"	34-3/8"	16-5/8"	16-3/4"	5"	Right Rear
FGC36S5E	36"	18"	3-1/2"	34-1/4"	34-3/8"	16-5/8"	16-3/4"	5"	Right Rear
FGC36S5A	36"	18"	3-1/2"	34-1/4"	34-3/8"	16-5/8"	16-3/4"	5"	Right Rear
FGC36C4A	36"	18-5/8"	3-1/4"	34-1/4"	34-3/8"	16-5/8"	16-3/4"	5"	Mid-Front
30" Cooktops									
PLGC30S9E	30"	21-1/2"	2-3/4"	27-1/4"	28-1/2"	19-1/8"	19-3/4"	8"	Right Rear
GLGC30S9E	30"	21-1/2"	2-3/4"	27-1/4"	28-1/2"	19-1/8"	19-3/4"	8"	Right Rear
GLGC30S8E	30"	21-1/2"	2-3/4"	26-5/8"	26-7/8"	19"	19-3/4"	5"	Right Rear
FGC30S4D	30"	21-1/2"	3-1/8"	26-5/8"	26-7/8"	19"	19-3/8"	5"	Right Rear
FGC30S4A	30"	21-1/2"	3-1/8"	26-5/8"	26-7/8"	19"	19-3/8"	5"	Right Rear
FGC30C3A	30"	21-1/2"	3-1/8"	26-5/8"	26-7/8"	19"	19-3/8"	5"	Right Rear
26" Cooktops									
FGC26C3A	25-3/4"	21-9/16"	3-1/2"	25"	25"	20-1/2"	20-1/2"	5"	Right Rear

ELECTRIC COOKTOP DIMENSIONS

Models	Exterior Dimensions			Cutout Dimensions				F-Clearance Required U/C	Electrical Connection
	A-Width	B-Depth	C-Height	D-Width		E-Depth			
				Minimum	Maximum	Minimum	Maximum		
36" Cooktops									
PLEC36S9E	36-3/4"	21-1/2"	3-1/4"	35-5/8"	36-1/8"	20-1/4"	20-1/2"	6"	Left Front
GLEC36S9E	36-3/4"	21-1/2"	3-1/4"	35-5/8"	36-1/8"	20-1/4"	20-1/2"	6"	Left Front
GLEC36S8E	36-3/4"	21-3/8"	3-1/4"	35-5/8"	36-1/8"	20-1/4"	20-1/2"	5"	Middle
FEC36S7E	36-3/4"	21-3/8"	3-1/4"	35-5/8"	36-1/8"	20-1/4"	20-1/2"	5"	Middle
FEC36S6E	36-3/4"	21-3/8"	3-1/4"	35-5/8"	36-1/8"	20-1/4"	20-1/2"	5"	Middle
FEC36C4A	36"	21-1/2"	3"	32-3/4"	34-1/4"	19"	20"	5"	Right Rear
FEC36C2A	36"	18"	3-7/8"	34-1/4"	34-3/8"	16-5/8"	16-3/4"	5-7/8"	Mid-Front
32" Cooktops									
FEC32S6A	32-1/4"	20-1/4"	3-3/4"	31"	31-1/4"	19"	19-1/4"	5-3/4"	Left Side
FEC32C4A	32-1/4"	20-1/4"	3-3/4"	31"	31-1/4"	19"	19-1/4"	5-3/4"	Left Side
30" Cooktops									
PLEC30S9E	30-3/4"	21-1/2"	4-5/8"	29-5/8"	29-3/4"	20-1/4"	20-1/2"	6"	Right Rear
GLEC30S9E	30-3/4"	21-1/2"	4-5/8"	29-5/8"	29-3/4"	20-1/4"	20-1/2"	6"	Right Rear
GLEC30S8E	30-3/4"	21-3/8"	3-1/4"	29-5/8"	29-7/8"	20-1/4"	20-1/2"	5"	Right Rear
FEC30S7E	30-3/4"	21-3/8"	3-1/4"	29-5/8"	29-7/8"	20-1/4"	20-1/2"	5"	Right Rear
FEC30S6D	30-3/4"	21-3/8"	3"	29-5/8"	29-7/8"	20-1/4"	20-1/2"	5"	Right Rear
FEC30S6A	30-3/4"	21-3/8"	3"	29-5/8"	29-7/8"	20-1/4"	20-1/2"	5"	Right Rear
FEC30C4A	30"	21-1/2"	3"	26-3/4"	28-1/4"	19-1/8"	20"	5"	Right Rear
26" Cooktops									
FEC26C2A	25-3/4"	21-9/16"	3-1/2"	25"	25"	20-1/2"	20-1/2"	5-1/2"	Right Rear

DOWNDRAFT VENT WITH COOKTOP INSTALLATION

The following dimension and cutout information for the PL36DD50E and PL30DD50E downdraft vent is for planning purposes only. For complete installation details consult manual packed with product, or download manual at Customer Service, online at frigidaire.com.

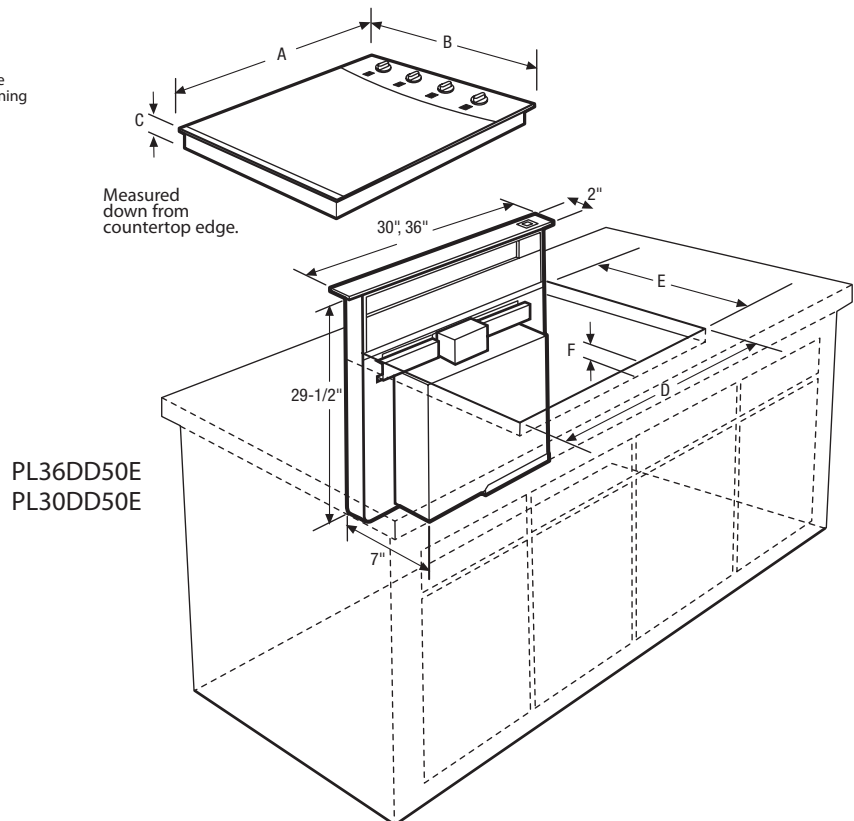

PL36DD50E
PL30DD50E

VENTILATION SYSTEMS

Models	PL36WC50E	PL36PC50E	PL42WC51E	PL36WC51E	PL30WC51E	PL36WC40E	PL36PC40E	PL36DD50E	PL30DD50E	PL36WC41E	PL30WC41E
Series	Professional	Professional	Professional	Professional	Professional	Professional	Professional	Professional	Professional	Professional	Professional
Features											
Nominal Width	36"	36"	42"	36"	30"	36"	36"	36"	30"	36"	30"
Installation	Wall Mount	Island	Wall Mount	Wall Mount	Wall Mount	Wall Mount	Island	Downdraft	Downdraft	Overhead	Overhead
Air Discharge	Vertical	Vertical	Vertical	Vertical	Vertical	Vertical	Vertical	Down	Down	Vertical or Horizontal	Vertical or Horizontal
Air Delivery (CFM)	500	500	500	500	500	400	400	500	500	400	400
Blower Type	Centrifugal	Centrifugal	Centrifugal	Centrifugal	Centrifugal	Centrifugal	Dual Centrifugal	Centrifugal	Centrifugal	Centrifugal	Centrifugal
Fan Speeds	3	3	3	3	3	4	4	Infinite	Infinite	3-Speed	3-Speed
Exhaust Duct	Convertible	Convertible	Convertible	Convertible	Convertible	Convertible	Convertible	External	External	Convertible	Convertible
Diameter of Duct	8"	6"	6"	6"	6"	6"	6"	3-1/4" x 10"	3-1/4" x 10"	3-1/4" x 10" or 7"	3-1/4" x 10" or 7"
Color/UPC (0-12505-)											
Stainless Steel (C)	55765-1	55766-8	55779-8	55757-6	55756-9	55714-9	55764-4	55753-8	55752-1	55763-7	55762-0
Specifications											
Shipping Weight (Approx.)	118-5/8 Lbs.	91-1/2 Lbs.	44-1/2 Lbs.	42 Lbs.	39 Lbs.	67-1/4 Lbs.	87 Lbs.	84-1/2 Lbs.	81 Lbs.	31-3/4 Lbs.	29 Lbs.
Exterior Width	35-7/16"	35-7/16"	42"	36"	30"	35-7/16"	35-7/16"	36"	30"	36"	30"
Exterior Height (Min.-Max)	29-5/16" - 41-1/8"	29-15/16" - 48-1/2"	34" - 44"	34" - 44"	34" - 44"	31" - 43-1/2"	33-7/16" - 42-3/8"	29-1/2"	29-1/2"	7-1/4"	7-1/4"
Exterior Depth	18-15/16"	19-5/8"	19-3/4"	19-3/4"	19-3/4"	19-5/8"	20-1/4"	7"	7"	20"	20"

Check local building codes for installation requirements, as they may vary per locale.

OPTIONAL ACCESSORIES

Models	PL36WC50E	PL36PC50E	PL42WC51E	PL36WC51E	PL30WC51E	PL36WC40E	PL36PC40E	PL36DD50E	PL30DD50E	PL36WC41E	PL30WC41E
Duct-Free Kit (Single Pack)	DFKTWC50EC	DFKTWC50EC	DFKTWC51EC	DFKTWC51EC	DFKTWC51EC	DFKTWC40EC	DFKTWC40EC			5304455850	5304455849
Duct-Free Kit (8-Pack)										DFKIT368PK	DFKIT308PK
Damper Kit (6-Pack)										DAMPKIT6PK	DAMPKIT6PK
7" Round Damper Kit (Single Pack)										5304455851	5304455851
Top Trim Kit -											
White								HT2736W	HT2730W		
Black								HT2736B	HT2730B		
Charcoal Filter	CF40EC	CF40EC	CF51EC	CF51EC	CF51EC	CF40EC	CF40EC				
Flue Extensions (10' Ceilings)	FXWC50EC	FXPC50EC	FXWC51EC	FXWC51EC	FXWC51EC	FXWC40EC	FXPC40EC				

INSTALLATIONS

The following dimension and cutout information is for planning purposes only. For complete installation details consult manual packed with product, or download manual at Customer Service, online at fridgidaire.com.

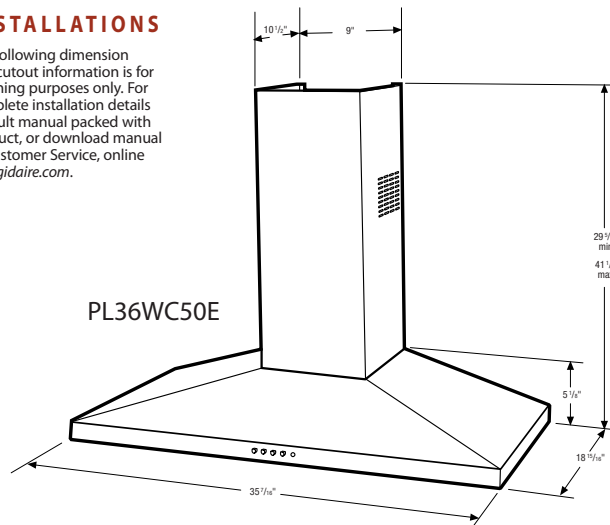

PL36WC40E

Dimensions from base of hood to ceiling, and include clearance required for installation.

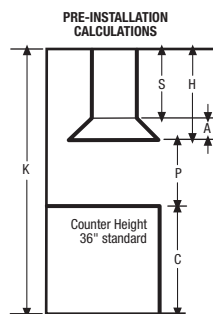
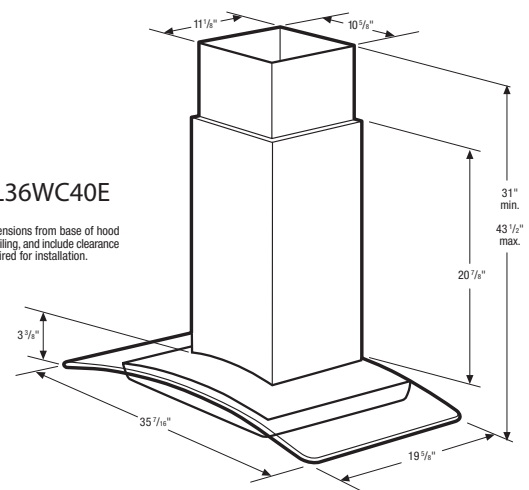

PL36PC50E, PL36PC40E Island Installation

Pre-Installation Calculations

- Select hood preference height (P) that is comfortable for user (30" recommended, 24"-30" allowed).
- Calculate hood height (H) for installation ($H = K - C - P$).
- Confirm that (H) is within minimum to maximum range for hood. If not, adjust installation.
- Calculate chimney structure height (S). Use formulas, check dimensions of hood. Save calculation for use later in installation.

K = Kitchen height
 C = Counter height
 P = Preferred height of hood bottom above counter (recommended 30")
 A = Canopy height
 H = Hood height for installation
 $H = K - C - P$
 S = Chimney structure height for installation
 $S = H - A$

PL42WC51E, PL36WC51E, PL30WC51E

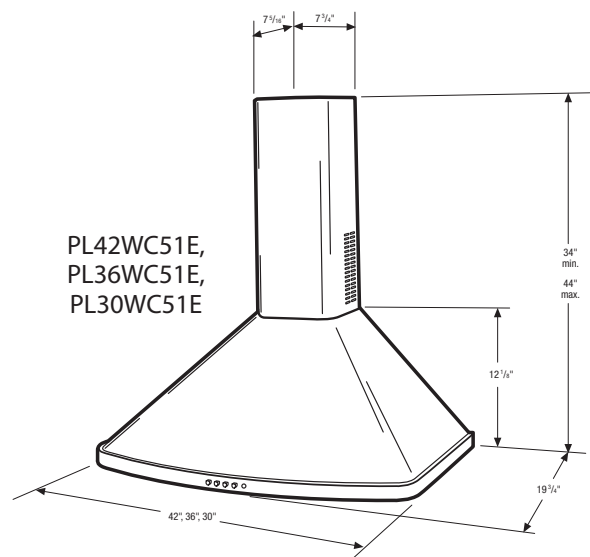

Models	GL36WC41E	GL30WC41E	F42WC19E*	F36WC19E	F30WC19E	F30WV16E	F30WR01E	F24WR01E*
Series	Gallery	Gallery	Frigidaire	Frigidaire	Frigidaire	Frigidaire	Frigidaire	Frigidaire
Features								
Nominal Width	36"	30"	42"	36"	30"	30"	30"	24"
Installation	Overhead	Overhead	Overhead	Overhead	Overhead	Overhead	Overhead	Overhead
Air Discharge	Vertical or Horizontal	Vertical or Horizontal	Vertical or Horizontal	Vertical or Horizontal	Vertical or Horizontal	Vertical or Horizontal	Re-Circulating	Re-Circulating
Air Delivery (CFM)	400	400	160-Horz/Vert,190-7Rd.	160-Horz/Vert,190-7Rd.	160-Horz/Vert,190-7Rd.	160		
Blower Type	Centrifugal	Centrifugal	Fan	Fan	Fan	Fan	Fan	Fan
Fan Speeds	3-Speed	3-Speed	2	2	2	2	2	2
Exhaust Duct	Convertible	Convertible	Convertible	Convertible	Convertible	External		
Diameter of Duct	3-1/4" x 10" or 7"	3-1/4" x 10" or 7"	3-1/4" x 10" or 7"	3-1/4" x 10" or 7"	3-1/4" x 10" or 7"	3-1/4" x 10"		
Color/UPC (0-12505-)								
Stainless Steel (C)				55743-9	55739-2	55732-3	55727-9	
White (S)	55760-6	55758-3	55783-5	55740-8	55736-1	55729-3	55724-8	55728-6
Black (B)	55761-3	55759-0	55784-2	55742-2	55738-5	55731-6	55726-2	
Bisque (Q)			55785-9	55741-5	55737-8		55725-5	
Specifications								
Shipping Weight (Approx.)	31-3/4 Lbs.	29 Lbs.	17 Lbs.	14-1/2 Lbs.	12-1/2 Lbs.	12-1/2 Lbs.	13-1/2 Lbs.	10-1/2 Lbs.
Exterior Width	36"	30"	42"	36"	30"	30"	30"	24"
Exterior Height (Min.-Max)	7-1/4"	7-1/4"	6"	6"	6"	6"	6"	6"
Exterior Depth	20"	20"	17-1/2"	17-1/2"	17-1/2"	17-1/2"	17-1/2"	17-1/2"

* Factory-direct only.



Models	GL36WC41E	GL30WC41E	F42WC19E	F36WC19E	F30WC19E	F30WV16E	F30WR01E	F24WR01E
Duct-Free Kit (Single Pack)	5304455850	5304455849	5304455848	5304455848	5304455848			
Duct-Free Kit (8-Pack)	DFKIT368PK	DFKIT308PK						
Duct-Free Kit (6-Pack)			DFKIT306PK	DFKIT306PK	DFKIT306PK			
Damper Kit (6-Pack)	DAMPKIT6PK	DAMPKIT6PK						
7" Round Damper Kit (Single Pack)	5304455851	5304455851						

PL36WC41E, PL30WC41E
GL36WC41E, GL30WC41E

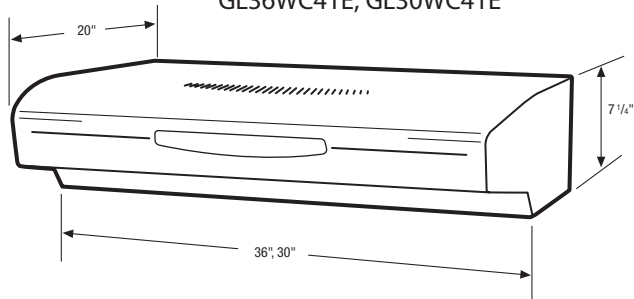

F42WC19E*, F36WC19E,
F30WC19E, F30WV16E

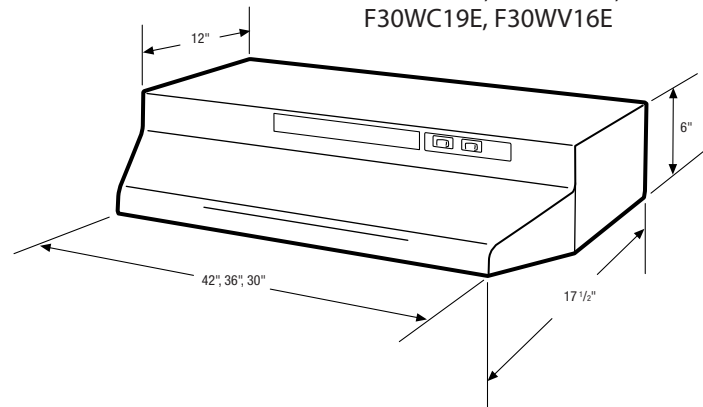

PL36DD50E, PL30DD50E

(Refer to page 9
for Installation
Dimensions)

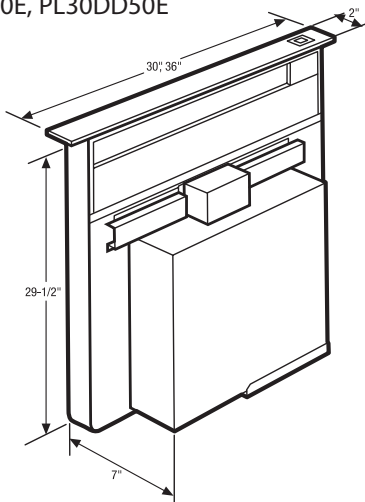

F30WR01E, F24WR01E*

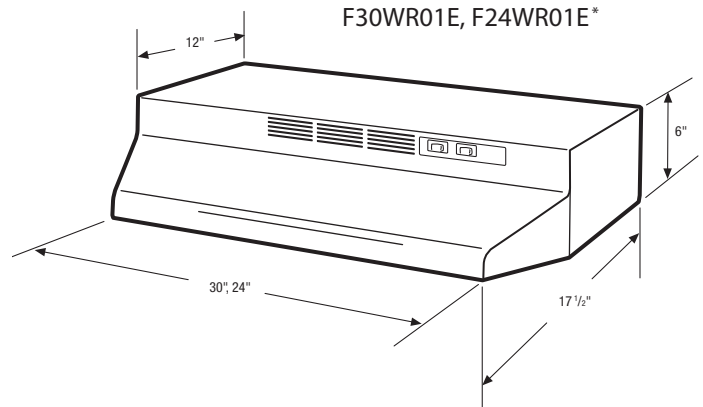



LIMITED ONE-YEAR WARRANTY

This warranty does not cover the following:

- Products with original serial numbers that have been removed, altered or cannot be readily determined.
- Product that has been transferred from its original owner to another party or removed outside the USA or Canada.
- Rust on the interior or exterior of the unit.
- Products purchased "as-is" are not covered by this warranty.
- Food loss due to any refrigerator or freezer failures.
- Products used in a commercial setting.
- Service calls which do not involve malfunction or defects in materials or workmanship, or for appliances not in ordinary household use or used other than in accordance with the provided instructions.
- Service calls to correct the installation of your appliance or to instruct you how to use your appliance.
- Expenses for making the appliance accessible for servicing, such as removal of trim, cupboards, shelves, etc., which are not a part of the appliance when it is shipped from the factory.
- Service calls to repair or replace appliance light bulbs, air filters, water filters, other consumables, or knobs, handles, or other cosmetic parts.
- Surcharges including, but not limited to, any after hour, weekend, or holiday service calls, tolls, ferry trip charges, or mileage expense for service calls to remote areas, including the state of Alaska.
- Damages to the finish of appliance or home incurred during installation, including but not limited to floors, cabinets, walls, etc.
- Damages caused by: services performed by unauthorized service companies; use of parts other than genuine Electrolux parts or parts obtained from persons other than authorized service companies; or external causes such as abuse, misuse, inadequate power supply, accidents, fires, or acts of God.

DISCLAIMER OF IMPLIED WARRANTIES; LIMITATION OF REMEDIES

Customer's sole and exclusive remedy under this limited warranty shall be product repair or replacement as provided herein. Claims based on implied warranties, including warranties of merchantability or fitness for a particular purpose, are limited to one year or the shortest period allowed by law, but not less than one year. Electrolux shall not be liable for consequential or incidental damages such as property damage and incidental expenses resulting from any breach of this written limited warranty or any implied warranty. Some states and provinces do not allow the exclusion or limitation of incidental or consequential damages, or limitations on the duration of implied warranties, so these limitations or exclusions may not apply to you. This written warranty gives you specific legal rights. You may also have other rights that vary from state to state.

IF YOU NEED SERVICE

Keep your receipt, delivery slip, or some other appropriate payment record to establish the warranty period should service be required. If service is performed, it is in your best interest to obtain and keep all receipts. Service under this warranty must be obtained by contacting Electrolux at the addresses or phone numbers below. Your appliance is covered by a one year limited warranty. For one year from your original date of purchase, Electrolux will pay all costs for repairing or replacing any parts of this appliance that prove to be defective in materials or workmanship when such appliance is installed, used, and maintained in accordance with the provided instructions. This warranty only applies in the USA and Canada. In the USA, your appliance is warranted by Electrolux Major Appliances North America, a division of Electrolux Home Products, Inc. In Canada, your appliance is warranted by Electrolux Canada Corp. Electrolux authorizes no person to change or add to any obligations under this warranty. Obligations for service and parts under this warranty must be performed by Electrolux or an authorized service company. Product features or specifications as described or illustrated are subject to change without notice.

USA

Electrolux Major Appliances, North America

250 Bobby Jones Expressway
Martinez, GA 30907
1-800-FRIGIDAIRE
frigidaire.com

CANADA

Electrolux Canada Corporation

5855 Terry Fox Way
Mississauga, ON L5V 3E4
1-800-668-4606



Every Frigidaire® appliance is backed by the global strength of the Electrolux Group, the world's largest manufacturer of kitchen and cleaning appliances.