

HOW TO REPLACE A CORD EQUALIZER FOR CELLULAR AND PLEATED SHADES

- First be sure the cord lock is locking the cords to hold the fabric compressed.
- Removed the broken equalizer by inserting a small screwdriver into the slot at the bottom of the equalizer and carefully pry off the cover (Figure 1)
- Install your new equalizer onto the lift cords. The bottom rail should be raised all the way and the cords should be hanging freely from the cord lock. Your shade may have the “System A” or “System B”
- In all systems, take the new equalizer, and snap the wedge piece away from the body piece. Slip the cords into the equalizer body, with the small end of the body toward the cord lock. Position the equalizer body about 1" below the point where you want the bottom rail to be when the shade is closed. Then slide the wedge into the body from the bottom (Figure 3). Do not lock the wedge completely into position; the equalizer should remain partially installed until you perform the next step.
- Then, you need to adjust the length of your shade. Lower the shade until is completely extended. Loosen the equalizer by holding the cords and sliding the body upwards to release the wedge. Level the bottom rail by pulling on each cord individually, or adjust the shade drop by moving the cords as a group. Then, while holding the lift cords at equal tension, move the equalizer body against the cord lock and slide the wedge securely into the body making sure the locking tab is against the cords holding them securely in place. After double-checking that the bottom rail is at the desired position, lock the wedge in place by pushing it against a flat surface until it is flush with the body.

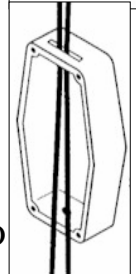
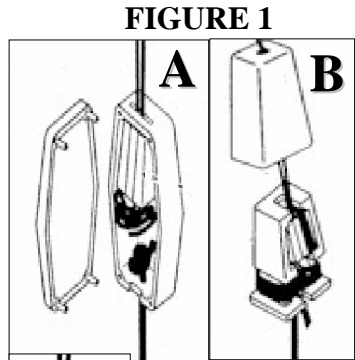

FIGURE 2

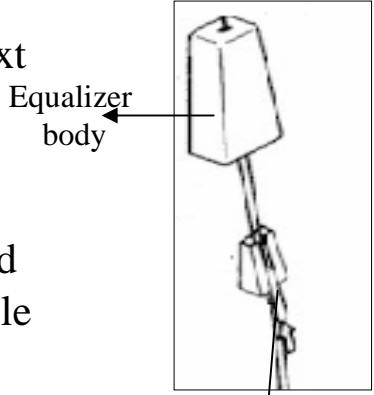

FIGURE 3

Important:

Be sure not to cross the lift cords; if crossed, the wedge cannot adequately secure them.

6. After locking the equalizer in position, trim the lift cords. No more than 3” should remain below the equalizer (figure 4) There should be enough cord length remaining to adjust for future adjustment, but not so much that the cords are too bulky to fit inside.
7. Twist the ends of the lift cords to make a nut and place it inside of the box.
8. Install the equalizer cover by fitting the four pegs on the cover into the holes on the equalizer body. (Figure 1A)
9. For “System B” Place the knotted end of the tassel cord into the slot at the base of the equalizer housing.
10. Wrap any excess lift cords once around the equalizer and push the equalizer back into the equalizer housing. (Figure 5)
11. Wrap remaining lift cords around the base of the housing and down through the slot at the bottom of the housing.
12. Holding the lift cords and Tassels cord taut, slide the cover over the equalizer housing assembly (Figure 6)
13. After checking the shade drop and making any final adjustments, trim any excess lift cords flush with the bottom of the equalizer housing.

FIGURE 4

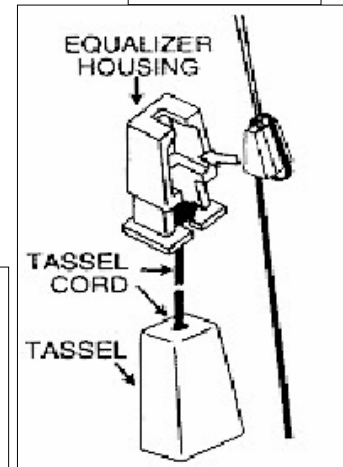
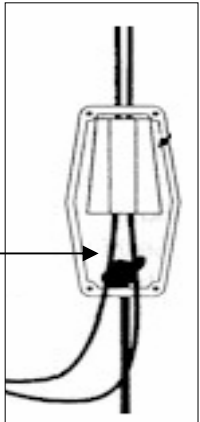

FIGURE 5

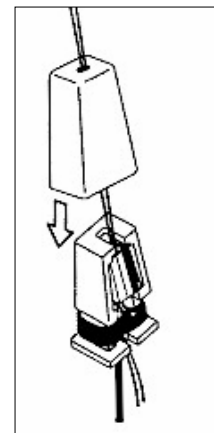

FIGURE 6



Parts for “System B”



Parts for “System A”