

# Under-Counter Ice Maker

EI15IM55G S



### Crystal-Clear Ice

Produces 7/8" cubed, restaurant-style ice by removing air bubbles and impurities during the freezing process. Ice cubes are always crystal clear and fresh-tasting.



### 30-Pound Ice Storage Capacity

Designed to fit anywhere, this unit can produce up to 60 pounds of crystal clear ice per day. 30-pound storage capacity provides constant and easy access to freshly supplied ice.



### Electronic Controls

Simple-to-use electronic controls schedule ice production throughout the day or night to meet specific ice demands.



### Self-Cleaning

The simple 3-step cleaning cycle safely removes the minerals and contaminants left behind from the "Fractional freezing" process, keeping ice pure and fresh.

## 15" UNDER-COUNTER ICE MAKER

Capacity	Up to 30 Lbs.
Installation Type	Built in/Freestanding

### Features

IQ-Touch™ Electronic Controls	Yes
Daily Ice Production	Up to 60 Lbs.
Clear Ice Cubes	Yes
Ice Cube Size	7/8"
Ice Cubes Produced per Cycle	32
Frost-Free Performance	Yes
3-Step Self-Cleaning Process	Yes
Self-Cleaning of Mineral Deposits	Yes
Commercial Grade Heavy-Duty Circulation Pump	Yes
Quiet Operation	Yes

### Additional Features

Signature Soft-Arc Door and Handle Design	Yes
Field-Reversible Door	Yes
Luxury-Close™ Door	Yes
Adjustable Leveling Legs	4

### Accessories

Ice Scoop	Included
Cleaning Kit – EIM41978	Optional
Drain Pump Kit - EIMP60 (to be used if gravity-assisted drain is not available)	Optional

### Specifications

Color –	Stainless Steel	S
Overall Exterior Dimensions –		
Height (Adjustable)	34" – 35-1/4"	
Width	14-7/8"	
Depth (Excluding Handle) (with 90° Door Open)	24-1/8" / 38-1/4"	
Power Supply/ Water Inlet Location	Left Bottom Rear	
Voltage Rating	120V/60Hz/15A	
Connected Load (kW Rating) @ 120 Volts‡	0.48	
Minimum Circuit Required (Amps)	15	
Gravity Assisted Drain	Required	
Product Weight	100 Lbs.	
Shipping Weight (Approx.)	109 Lbs.	

‡For use on adequately wired 120V, dedicated circuit having 2-wire service with a separate ground wire. Appliance must be grounded for safe operation.

NOTE: Always consult local and/or national electric codes. Refer to Product Installation Guide for detailed installation instructions on the web at [electroluxappliances.com](http://electroluxappliances.com).

Specifications subject to change.

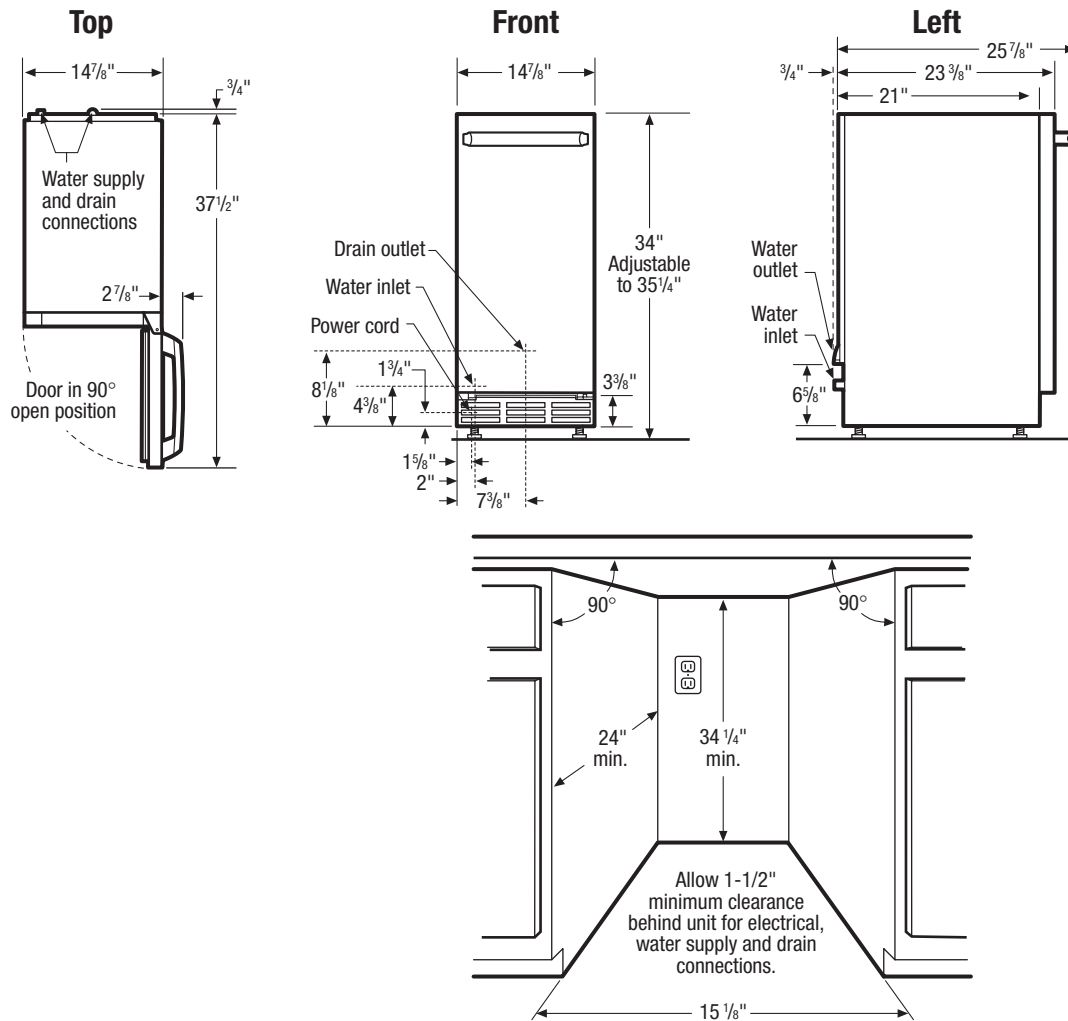

## Under-Counter Ice Maker Specifications

- Product Weight – 100 Lbs.
- Voltage Rating – 120V/60Hz/ 15 Amps
- Connected Load (kW Rating) @ 120 Volts = 0.48kW  
(For use on adequately wired 120V, dedicated circuit having 2-wire service with a separate ground wire. Appliance must be grounded for safe operation.)
- Amps @ 120 Volts = 4 Amps
- Electrical cable supplied.
- Water supply and electrical power source required.
- Always consult local and/or national electric & plumbing codes.
- Can be used freestanding, or built in under counter.
- Does not require additional airspace for top, sides or rear when used in built-in application. Increase unit dimensions by at least 1/4" for recommended rough opening, allowing 1-1/2" minimum clearance in rear for water, drain and electrical connections.
- Front grille MUST remain unobstructed for proper ventilation.
- Can be installed using gravity drain, or factory-installed/equivalent drain pump.
- Drain lines must have 5/8" inside diameter, 1" drop per 48" (1/4" per foot) of run and must not create traps.

- Floor drain must be large enough to accommodate drainage from all drains.
- Recommended water pressure between 15 and 150 pounds per square inch (psi).
- Unit MUST be level for proper operation, and positioned on flat surface, capable of supporting entire weight when fully loaded.
- Leveling legs supplied to adjust height and level unit.
- Can be installed outdoors, out of direct sunlight. Do NOT install behind closed doors.
- Do not position unit near any heat source or in direct sunlight to ensure optimum performance. Surrounding air temperature must be at least 50°F but must not exceed 110°F.
- Must be positioned to allow for 90° door swing. (Door is field reversible for right- or left-hand opening.)
- When installing next to wall where handle may make contact, allow 3" clearance between opened door and wall.

**Note:** For planning purposes only. Refer to Product Installation Guide on the web at [electroluxappliances.com](http://electroluxappliances.com) for detailed instructions.

### Optional Accessories

- Drain Pump Kit – (EIMP60).
- Cleaning Kit – (EIM41978).