

Under-Counter Beverage Center

EI24BC65G S



Integrated Electronic Controls

Reversible side-swing door with integrated electronic controls located conveniently on the top of the door ensure this unit will fit anywhere.



Luxury-Glide™ Glass Shelves

Shelves are so smooth they extend effortlessly.



Luxury-Design™ Lighting

Our ramp-up designer LED lighting is as beautiful as it is functional, keeping your beverages clearly visible. Display lighting feature provides ambient lighting to showcase bottles during storage.



UV-Filtered Glass Door

Tinted window helps protect wine's flavor from deterioration caused by harmful UV rays.

24" UNDER-COUNTER SIDE-SWING BEVERAGE CENTER

Sabbath Mode (Star-K® Certified)	Yes
Capacity	6 Cu. Ft.
Installation Type	Built In/Freestanding

Features

IQ-Touch™ Electronic Controls	Yes
Fully Integrated Control Panel	Yes
Electronic Control Lock	Yes
Blue LED Display	Yes
Frost-Free Performance	Yes
Dynamic Condenser	Yes
PureAdvantage™ Air Filter	Yes
Perfect Set™ Controls	Yes
Display Temp Mode (°C or °F)	Yes
Door Open Acoustic Alarm	Yes
High-Temperature Acoustic Alarm	Yes
Power Failure Acoustic Alarm	Yes
Mute Sound Control	Yes
Luxury-Design™ Lighting	Yes
Exhibit Lighting with Manual Control	Yes
Power-On/Off Control	Yes
Vacation Mode	Yes
Luxury-Glide™ Full-Extension Glass Shelves	2
Lower Level Display Rack	Yes
Black Soft Coat Wireform Wine Rack	Yes
Metal Front on Racks	Yes

Additional Features

Signature Soft-Arc Door and Handle Design	Yes
UV-Filtered, Tinted Glass Window	Yes
Luxury-Close™ Door	Yes
Adjustable Leveling Legs	4

Accessories

Field-Reversible Door Kit – 5303918374	Optional
--	----------

Specifications

Color –	
Stainless Steel	S
Overall Exterior Dimensions –	
Height (Adjustable)	34" – 35"
Width	23-13/16"
Depth (to Center of Arc)	24-1/4"
(with 90° Door Open)	47"
Temperature Range	35° F – 45° F
Power Supply Connection Location	Right Bottom Rear
Voltage Rating	120V/60Hz/15A
Connected Load (kW Rating) @ 120 Volts [†]	0.15
Minimum Circuit Required (Amps)	15
Product Weight	128 Lbs.
Shipping Weight (Approx.)	137 Lbs.

Optional accessories available on the web at electroluxappliances.com.

[†]For use on adequately wired 120V, dedicated circuit having 2-wire service with a separate ground wire. Appliance must be grounded for safe operation.

NOTE: Always consult local and/or national electric codes. Refer to Product Installation Guide for detailed installation instructions on the web at electroluxappliances.com.

Specifications subject to change.

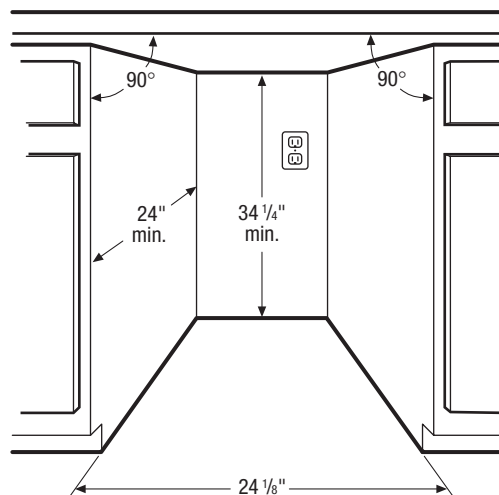
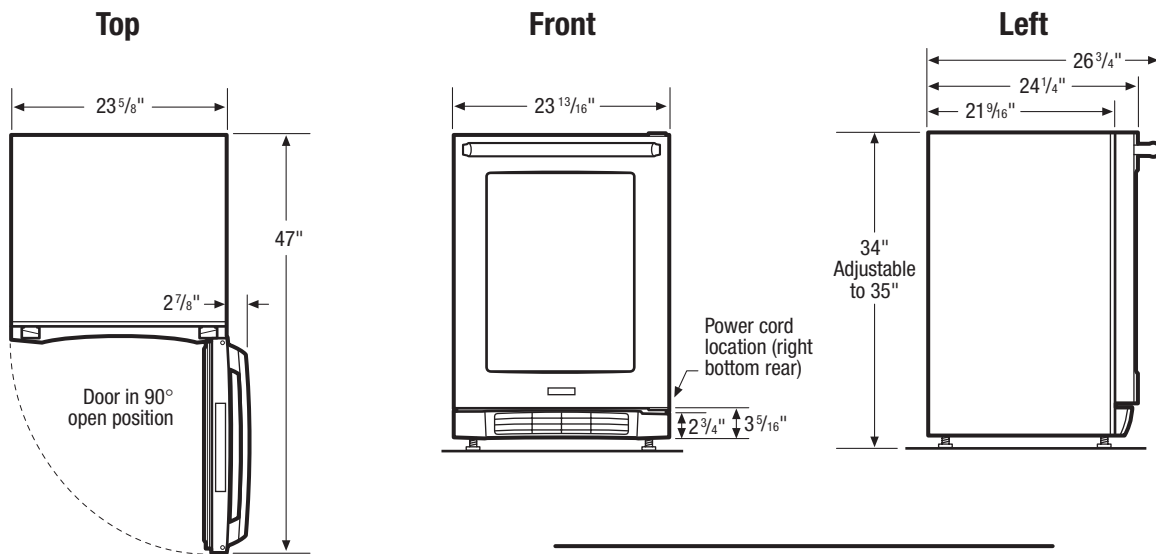

Under-Counter Beverage Center Specifications

- Product Weight – 128 Lbs.
- Voltage Rating – 120V/60Hz/15 Amps
- Connected Load (kW Rating) @ 120 Volts = 0.15kW (For use on adequately wired 120V, dedicated circuit having 2-wire service with a separate ground wire. Appliance must be grounded for safe operation.)
- Amps @ 120 Volts = 6 Amps
- Electrical cable supplied.
- Always consult local and/or national electric codes.
- Can be used freestanding, or built in under counter.
- Does not require additional airspace for top, sides or rear when used in built-in application. Increase unit dimensions by at least 1/4" for recommended rough opening.
- Front grille MUST remain unobstructed for proper ventilation.
- Must be positioned on flat, level surface, capable of supporting entire weight when fully loaded.

- Leveling legs supplied to adjust height and level unit.
- Do not position unit near any heat source to ensure optimum performance.
- Must be positioned to allow for 90° door swing, providing sliding shelves with necessary clearance. (Door is field reversible for right- or left-hand opening.)
- When installing next to wall where handle may make contact, allow 3" clearance between opened door and wall.

Note: For planning purposes only. Refer to Product Installation Guide on the web at electroluxappliances.com for detailed instructions.

Optional Accessories

- Field-Reversible Door Kit – (5303918374).