



Concrete Roof Tiles

FLORIDA/SOUTHEAST & NORTHEAST STANDARD WEIGHT COLLECTION



Concrete Roof Tiles

Few roof products are as beautiful or enduring as Boral concrete roof tiles. With so many styles and colors to choose from, you'll find that adding a tile roof to your home is one of the easiest and most effective ways to complement its look and increase its value.

Tile.

For the way it looks.

And the way it lasts.



Natural
& Extensive
Color Offering





Tile is timeless

Only tile enables you to achieve authentic, old-world aesthetics with the benefits of durable, modern materials. Boral Roofing has captured all the characteristics of natural slate, clay and wood – which are historically the world’s most widespread roofing materials – in a concrete tile. The result is a tile roof of unmatched beauty and a home with incredible curb appeal.

Boral Roofing is continually acknowledged by the industry for our product innovations. And three of our most popular products - Madera, Slate and Barcelona - replicate authentic materials, while reducing installation costs and increasing longevity and energy efficiency.



Always In Stock

Our most popular colors as chosen by you, our customer. Products noted as In Stock are our most readily available colors, please check with your local Sales Representative for current tile availability.

Code Approval: Complies with all building codes including but not limited to ICC ESR-1647. Some approvals are regional and only apply to locally produced products; please contact Boral Roofing before transporting product across state lines. Specifically, products used in the Miami Dade County region of Florida require special testing and recognition. All tiles are Class A fire rated.

Disclaimer: The printed colors shown in this brochure may vary from actual available tile colors. Before making a final selection, be sure to review actual tile samples and roof installations. Please contact your local sales office for further assistance. Categories, typographical errors subject to change without notice. No performance guarantee is offered or implied beyond that expressly indicated.

Efflorescence is a temporary surface condition which is common to all concrete products. The process is caused by the chemical nature of cement. This reaction can appear as an overall chalky white bloom (a softening of color) or in more concentrated patches. It is difficult to predict how long the effects of efflorescence will last. It depends on the type and amount of deposit as well as local weather conditions. The action of carbon dioxide and rainwater will gradually remove the deposit, in most cases, leaving the original color of the roof intact without further efflorescence occurring. It is superficial and in no way affects the quality or functional properties of the tile.

Installation: Please consult the Tile Roofing Institute (TRI) Installation guides for application recommendations.

Vanguard Roll

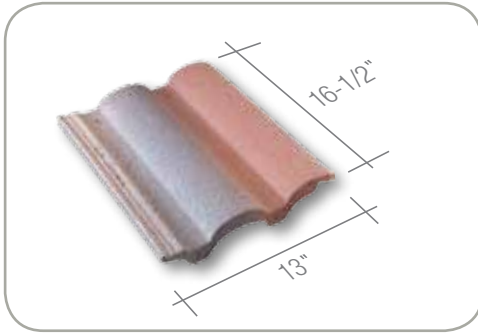

This tile is designed in the Mediterranean style but features a water channel rolled closer to the valley that hides the channel lock, improving aesthetics. Vanguard Roll features the most popular tile profile in the world, faithfully re-creating the beautiful Mediterranean style found in Italy and Southern France.

- Unique colors and blends can enhance any architectural theme
- Superior strength and durability of concrete tile

Coverage	Installed Weight/Square	Pieces/Pallet	Squares/Pallet	Weight/Pallet
At 3" minimum headlap, 91 field tiles will cover approx. 100 square feet of roof area.	Approx.: 840 lbs.	324	3.56	Approx.: 3170 lbs.



Choose from one of our many cool roof rated tiles that will improve the energy efficiency by reflecting sunlight and heat away from your roof. When these are combined with our Elevated Batten System, they will provide reduced cooling costs and they may even qualify for local rebates. The Cool Roof Rating Council (CRRC) measures the "coolness" of a roof by determining a roof's solar reflectance (SR) and thermal emittance (TE). Both properties are rated on a scale from 0 to 1, where 1 is the most reflective or emissive. The CRRC measures these two properties for roofing products, both for the product's initial values and after three years of weather exposure. Boral Roofing manufactures products that meet CRRC guidelines, allowing homeowners in some regions to receive utility rebates. Boral Roofing's CRRC rated products help reduce the heat island effect found in urban areas and in general, increases the overall energy efficiency of the building. For current product ratings please visit our website at www.boralna.com and click on CRRC logo on the home page.

Athenian Blend  **PREMIUM**

1VRMS6062



CRRC ID# – 0942-0042
Reflectance: 0.32 / Emittance: 0.90 / SRI: 34

Apple Cider  **STANDARD**

1VRCS0263



CRRC ID# – 0942-0039
Reflectance: 0.19 / Emittance: 0.89 / SRI: 17

Kahlua  **SPECIAL**

1VRMS3558



CRRC ID# – 0942-0036
Reflectance: 0.20 / Emittance: 0.90 / SRI: 19

Mission Sunset Color Coat* **STANDARD**

1VRSS6842



CRRC ID# – 0942-0035
Reflectance: 0.46 / Emittance: 0.91 / SRI: 53

Spanish Blend Color Coat*  **STANDARD**

1VRSS6789



CRRC ID# – 0942-0037
Reflectance: 0.33 / Emittance: 0.90 / SRI: 36

Marmalade **SPECIAL**

1VRMS6493



CRRC ID# – 0942-0108
Reflectance: 0.25 / Emittance: 0.90 / SRI: 25

Burnt Mission **SPECIAL**

1VRCS7117



Pinto Blend  **STANDARD**

1VRSS0689



CRRC ID# – 0942-0030
Reflectance: 0.27 / Emittance: 0.91 / SRI: 28

Champagne Cream  **SPECIAL**

1VRMS0190



CRRC ID# – 0942-0097
Reflectance: 0.26 / Emittance: 0.91 / SRI: 27

White C/T Color Coat*
1VRBS8001 **PREMIUM**



CRRC ID# - 0942-0027
Reflectance: 0.75 / Emittance: 0.91 / SRI: 93

Mission Red Color Coat*
1VRSS7027 **STANDARD**



Palm Island Green
1VRCS4358 **SPECIAL**



Cool Grey Color Coat*
1VRSS5547 **STANDARD**



CRRC ID# - 0942-0103
Reflectance: 0.57 / Emittance: 0.92 / SRI: 68

Arizona Clay 
1VRCS7049 **SPECIAL**



Chilled Avocado
1VRCS4624 **STANDARD**



CRRC ID# - 0942-0099
Reflectance: 0.25 / Emittance: 0.90 / SRI: 25

Sterling
1VRCS5759 **STANDARD**



Raspberry Sorbet
1VRCS7530 **STANDARD**



Spanish "S" Nuevo

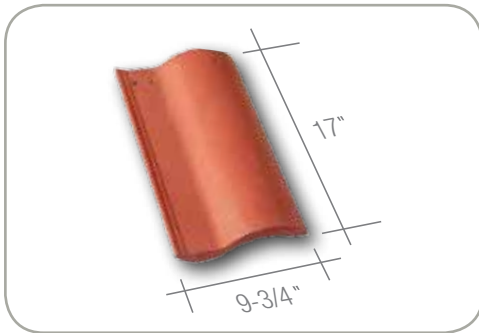

This modern interpretation of the old world Spanish design creates a distinctive two-piece mission tile appearance in a durable one-piece construction.

- Flexible coursing for easier installation
- Interlocking weather channels for improved performance
- Head lugs for batten installation
- Superior strength and durability of concrete tile
- Produced at our state-of-the-art manufacturing plant

Coverage	Installed Weight/Square	Pieces/Pallet	Squares/Pallet	Weight/Pallet
At 3" minimum headlap, 114 field tiles will cover approx. 100 square feet of roof area.	Approx.: 994 lbs.	380	3.33	Approx.: 3628 lbs.



Blush Blend

1NUCS6008

STANDARD



Cabernet Blend

1NUCS6007

STANDARD



Burnt Brick

1NUCS6027

STANDARD



CRRC ID# - 0942-0094
Reflectance: 0.26 / Emittance: 0.89 / SRI: 26

Sand Dollar

1NUCS0028

STANDARD



CRRC ID# - 0942-0113
Reflectance: 0.29 / Emittance: 0.90 / SRI: 31

Sangria Blend

1NUCS7006

STANDARD



Gold Spice

1NUCS6029

STANDARD



CRRC ID# - 0942-0104
Reflectance: 0.29 / Emittance: 0.88 / SRI: 30

Cantaloupe Marble

1NUWS6065

PREMIUM



CRRC ID# - 0942-0096
Reflectance: 0.32 / Emittance: 0.91 / SRI: 35

Spanish Clay

1NUCS6079

STANDARD



Gold Spice Marble

1NUCS6067

STANDARD



CRRC ID# - 0942-0105
Reflectance: 0.22 / Emittance: 0.89 / SRI: 21

Wildflower Blend 
1NUCS6023 **STANDARD**



Wildflower Blend tile sample showing a mix of brown, tan, and grey tones.

Café
1NUWS7032 **PREMIUM**



Café tile sample showing a uniform reddish-brown color.

Tangelo Marble
1NUWS6066 **PREMIUM**



Tangelo Marble tile sample showing a reddish-brown color with a marbled pattern.

CRRC ID# - 0942-0117
Reflectance: 0.39 / Emittance: 0.91 / SRI: 44

Sandstone Antique
1NUCS0296 **STANDARD**



Sandstone Antique tile sample showing a mix of brown and tan tones.

Flame Red
1NUCS7013 **STANDARD**



Flame Red tile sample showing a uniform reddish-brown color.

Tangelo
1NUWS6177 **PREMIUM**



Tangelo tile sample showing a uniform reddish-brown color.

CRRC ID# - 0942-0116
Reflectance: 0.47 / Emittance: 0.90 / SRI: 54

Florida Blend
1NUCS3903 **STANDARD**



Florida Blend tile sample showing a mix of brown and tan tones.

Terra Cotta
1NUCS6100 **STANDARD**



Terra Cotta tile sample showing a uniform reddish-brown color.

CRRC ID# - 0942-0049
Reflectance: 0.29 / Emittance: 0.89 / SRI: 30

Cantaloupe
1NUWS6312 **PREMIUM**



Cantaloupe tile sample showing a uniform reddish-brown color.

CRRC ID# - 0942-0095
Reflectance: 0.54 / Emittance: 0.91 / SRI: 64

Cactus Antique

1NUCS0354

STANDARD



Desert Antique

1NUCS0477

STANDARD



Meadow Blend

1NUCS4015

PREMIUM



Butterscotch Antique

1NUCS6826

STANDARD



Eldorado Antique

1NUCS6584

STANDARD



Dunes Tan Antique

1NUCS0290

STANDARD



Burlap Antique

1NUCS0052

STANDARD



Goldenrod

1NUCS6116

STANDARD



CRRC ID# – 0942-0043
Reflectance: 0.32 / Emittance: 0.89 / SRI: 34

Sand Dollar Marble

1NUCS0017

STANDARD



CRRC ID# – 0942-0114
Reflectance: 0.24 / Emittance: 0.88 / SRI: 23

Bedrock Blend

1NUCS5008

STANDARD



Charleston

Custom Blend¹



Butterscotch Antq. - 33%
Burlap Antq. - 33%; Sandstone Antq. - 33%

Brandywine

Custom Blend¹



Terra Cotta - 33%; Goldenrod - 33%
Spanish Clay - 33%

Sterling

1NUCS5759

STANDARD



Desert Sunset

Custom Blend¹



Eldorado Antq. - 33%
Cactus Antq. - 33%; Desert Antq. - 33%

Buttercup

Custom Blend¹



Eldorado Antq. - 25%; Cactus Antq. - 25%;
Desert Antq. - 25%; Dunes Tan Antq. - 25%

Verona White

1NUWS8003

STANDARD



CRRC ID# - 0942-0052
Reflectance: 0.67 / Emittance: 0.91 / SRI: 82

¹When ordering a custom color blend, each color must be ordered separately in half or full pallet quantities. Boral Roofing does not pre-blend custom blends at the factory. In order to avoid any possible unwanted color patterning during the installation, the skilled installer should periodically view the roof from the ground level at a distance of about 50 feet. This procedure will help ensure the desired random look, help avoid "hot spots", checker boarding, streaks or stair stepping. Acceptable blending can only be done during the installation process.

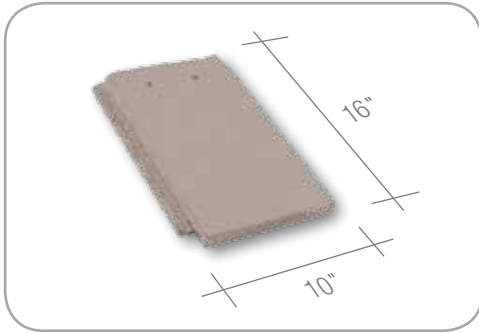

Give your home the relaxing feel of a Bermuda estate with these unique, flat profile tiles.

- Unique colors and hues give your home a distinctive Caribbean appearance
- Superior strength and durability of concrete tile

Coverage	Installed Weight/Square	Pieces/Pallet	Squares/Pallet	Weight/Pallet
At 3" minimum headlap, 123 field tiles will cover approx. 100 square feet of roof area.	Approx.: 1040 lbs.	351	2.85	Approx.: 3604 lbs.



Terra Cotta Unsealed
1ATCU6100 **STANDARD**



CRRC ID# - 0942-0049
Reflectance: 0.29 / Emittance: 0.89 / SRI: 30

Lignite Unsealed 
1ATCU0035 **STANDARD**



Sterling
1ATCU5759 **STANDARD**



Sandstone Unsealed
1ATCU0396 **STANDARD**



CRRC ID# - 0942-0051
Reflectance: 0.31 / Emittance: 0.87 / SRI: 32

San Remo Grey Textured Unsealed
1ATCQ5002 **STANDARD**





CRRC ID# - 0942-0053
Reflectance: 0.33 / Emittance: 0.88 / SRI: 35

San Remo Grey Unsealed
1ATCU5002 **STANDARD**



CRRC ID# - 0942-0053
Reflectance: 0.33 / Emittance: 0.88 / SRI: 35

Verona White Unsealed 
1ATWU8003 **PREMIUM**



CRRC ID# - 0942-0052
Reflectance: 0.67 / Emittance: 0.91 / SRI: 82

 In Stock item available in Pompano Beach, FL



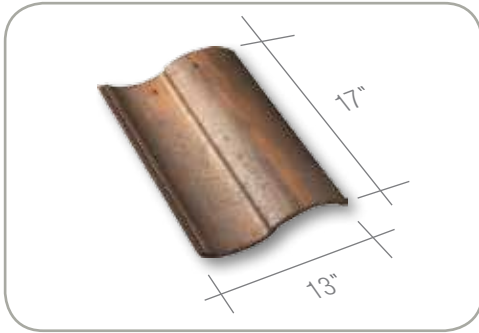



Barcelona 900 is designed to reflect the classic style and distinctiveness of Spanish architecture, popular in the early California missions that stretched from San Diego de Alcalá to San Francisco Solamo.

- Classic style with the durability and value of concrete tile
- Distinct hue combinations that create a beautiful, rustic appearance

Coverage	Installed Weight/Square	Pieces/Pallet	Squares/Pallet	Weight/Pallet
At 3" minimum headlap, 85 field tiles will cover approx. 100 square feet of roof area.	Approx.: 850 lbs.	256	3.01	Approx.: 2785 lbs.



Casa Grande Blend 
1HBCS6144 **STANDARD**





CRRC ID# - 0942-0014
Reflectance: 0.23 / Emittance: 0.91 / SRI: 23

Florida Blend 
1HBCS3903 **STANDARD**



Desert Spice Blend
1HBCS6313 **SPECIAL**



Gold Dust 
1HBCS7165 **STANDARD**



Buckskin
1HBCS0141 **STANDARD**



CRRC ID# - 0942-0009
Reflectance: 0.22 / Emittance: 0.90 / SRI: 22

Burnt Mission Color Coat*
1HBSS7117 **STANDARD**





Citrus Clay 
1HBWS7656 **PREMIUM**



CRRC ID# - 0942-0054
Reflectance: 0.50 / Emittance: 0.91 / SRI: 59

Sterling
1HBCS5759 **STANDARD**



Spanish Blend Color Coat* 
1HBSS6789 **STANDARD**



CRRC ID# - 0942-0037
Reflectance: 0.33 / Emittance: 0.90 / SRI: 36

Chestnut Burnt

1HBCS3242

STANDARD



Campfire Blend

1HBCS6311

SPECIAL



Tangelo

1HBWS6177

PREMIUM



CRRC ID# - 0942-0116
Reflectance: 0.47 / Emittance: 0.90 / SRI: 54

New Southern Blend

1HBCS0100

STANDARD



Café

1HBWS7032

PREMIUM



Mission Sunset

1HBSS6842

STANDARD



CRRC ID# - 0942-0035
Reflectance: 0.46 / Emittance: 0.91 / SRI: 53

Pinto Blend Color Coat*

1HBSS0689

STANDARD



CRRC ID# - 0942-0030
Reflectance: 0.27 / Emittance: 0.91 / SRI: 28

Raspberry Sorbet

1HBCS7530

STANDARD



Cantaloupe

1HBWS6312

PREMIUM



CRRC ID# - 0942-0095
Reflectance: 0.54 / Emittance: 0.91 / SRI: 64

Vermont Green
1HBCS4513 SPECIAL



Barbados Blend
1HBCS6423 SPECIAL



White C/T Color Coat*
1HBBS8001 PREMIUM



CRRC ID# – 0942-0027
Reflectance: 0.75 / Emittance: 0.91 / SRI: 93

Khaki Blend
1HBCS0140 STANDARD



Canyon Dusk Blend
1HBCS0025 SPECIAL



Buttercup
1HBWS6215 PREMIUM



*Color Coat products are not available in Southeast & Northeast regions.

Boosted Barcelona Caps

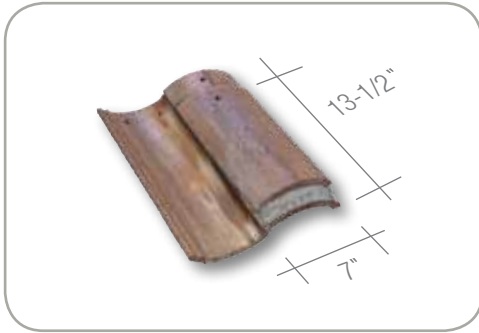

Boosted Barcelona is an available installation application of Barcelona 900 which, when combined with Barcelona 900 field tiles, creates the appearance of an authentic mortar-boosted tile.

- Available in colors that emulate the warm, rustic tones of natural clay
- Superior manufacturing techniques make Boosted Barcelona simple to install – reducing installation costs

Installed Weight / Square	Pieces/Pallet	Weight/Pallet
10% - Approx. 9 caps per sq. 940 - 950 lbs.	244	Approx.: 1270 lbs.
20% - Approx. 18 caps per sq. 980 - 1000 lbs.		
30% - Approx. 27 caps per sq. 1020 - 1050 lbs.		



Casa Grande Blend

1BLCS6144K



CRRC ID# - 0942-0014
Reflectance: 0.23 / Emittance: 0.91 / SRI: 23

New Southern Blend

1BLCS0100K



Khaki Blend

1BLCS0140K



Gold Dust

1BLCS7165K



Florida Blend

1BLCS3903K



Vermont Green

1BLCS4513K



Citrus Clay White Cement

1BLWS7656K



CRRC ID# - 0942-0054
Reflectance: 0.50 / Emittance: 0.91 / SRI: 59

Buckskin

1BLCS0141K



CRRC ID# - 0942-0009
Reflectance: 0.22 / Emittance: 0.90 / SRI: 22

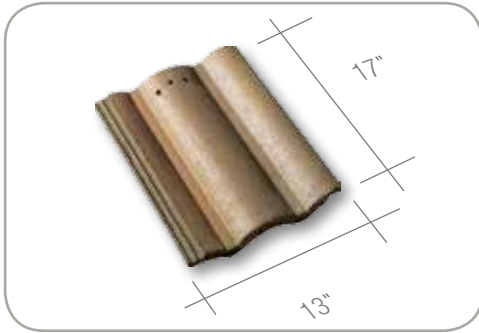

Villa 900 emulates the most popular tile profile in the world, faithfully re-creating the beautiful Mediterranean style found in Italy and Southern France.

- Unique colors and blends can enhance any architectural theme
- Superior strength and durability of concrete tile

Coverage	Installed Weight/Square	Pieces/Pallet	Squares/Pallet	Weight/Pallet
At 3" minimum headlap, 85 field tiles will cover approx. 100 square feet of roof area.	Approx.: 920 lbs.	296	3.48	Approx.: 3498 lbs.



Champagne Cream
1MPMS0190 **STANDARD**





CRRC ID# - 0942-0097
Reflectance: 0.26 / Emittance: 0.91 / SRI: 27

Casa Grande Blend 
1MPCS6144 **STANDARD**



CRRC ID# - 0942-0014
Reflectance: 0.23 / Emittance: 0.91 / SRI: 23

New Southern Blend 
1MPCS0100 **STANDARD**





Buff Flash Color Coat*
1MPSS0210 **STANDARD**



CRRC ID# - 0942-0032
Reflectance: 0.33 / Emittance: 0.92 / SRI: 37

Gold Dust
1MPCS7165 **STANDARD**



Tequila Sunset Color Coat* 
1MPSS6172 **STANDARD**





CRRC ID# - 0942-0034
Reflectance: 0.26 / Emittance: 0.92 / SRI: 28

Taupe Mist Color Coat* 
1MPSS0156 **STANDARD**



Raspberry Sorbet
1MPCS7530 **STANDARD**



Mission Sunset Color Coat* 
1MPSS6842 **STANDARD**



CRRC ID# - 0942-0035
Reflectance: 0.46 / Emittance: 0.91 / SRI: 53

Pinto Blend Color Coat*  **STANDARD**

1MPSS0689



CRRC ID# - 0942-0030
Reflectance: 0.27 / Emittance: 0.91 / SRI: 28

Hopi Blend Color Coat* **STANDARD**

1MPSS0644



CRRC ID# - 0942-0033
Reflectance: 0.49 / Emittance: 0.90 / SRI: 57

White C/T Color Coat*  **PREMIUM**

1MPBS8001



CRRC ID# - 0942-0027
Reflectance: 0.75 / Emittance: 0.91 / SRI: 93

Arbor Green **SPECIAL**

1MPCS4590



Amber Sand Color Coat* **STANDARD**

1MPSS0555



CRRC ID# - 0942-0092
Reflectance: 0.56 / Emittance: 0.90 / SRI: 67

Sterling **STANDARD**

1MPCS5759



Tequila Sunset



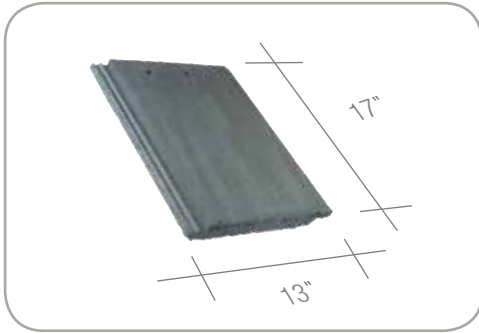



This beautiful design is representative of the roof styles found in England, Northern Europe and the Eastern Seaboard states; and is versatile enough to accentuate any architectural style.

Available in a broad range of colors, it faithfully captures the appearance of natural slate.

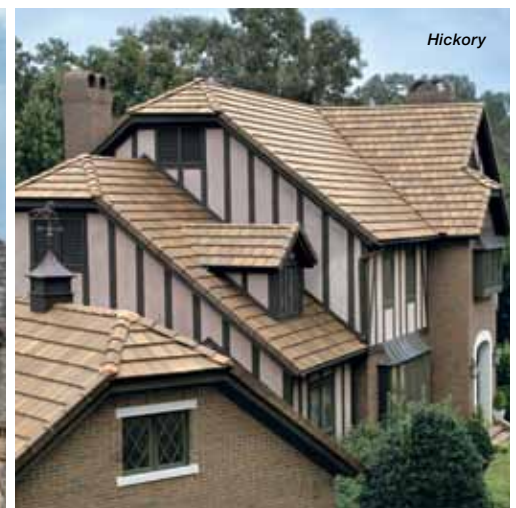
Coverage	Installed Weight/Square	Pieces/Pallet	Squares/Pallet	Weight/Pallet
At 3" minimum headlap, 85 field tiles will cover approx. 100 square feet of roof area.	Approx.: 950 lbs.	288	3.39	Approx.: 3405 lbs.



White C/T Color Coat*  **PREMIUM**

1FABS8001



CRRC ID# - 0942-0027
Reflectance: 0.75 / Emittance: 0.91 / SRI: 93

Starburst  **STANDARD**

1FACS7144



Palm Island Green  **SPECIAL**

1FACS4358



 In Stock item available in Lake Wales, FL

 In Stock item available in Pompano Beach, FL

Dark Charcoal Blend 
1FACS1135 **STANDARD**



Dark Charcoal Blend is a dark grey, charcoal-colored roof tile with a wood-grain texture.

Buckskin 
1FACS0141 **STANDARD**



Buckskin is a light brown, tan-colored roof tile with a wood-grain texture.

CRRC ID# – 0942-0009
Reflectance: 0.22 / Emittance: 0.90 / SRI: 22

Florida Blend 
1FACS3903 **STANDARD**



Florida Blend is a dark brown, mahogany-colored roof tile with a wood-grain texture.

Stone Mountain Blend 
1FACS5354 **STANDARD**



Stone Mountain Blend is a dark grey, charcoal-colored roof tile with a wood-grain texture.

CRRC ID# – 0942-0047
Reflectance: 0.17 / Emittance: 0.90 / SRI: 15

Hickory 
1FACS3726 **STANDARD**



Hickory is a light brown, tan-colored roof tile with a wood-grain texture.

CRRC ID# – 0942-0065
Reflectance: 0.15 / Emittance: 0.93 / SRI: 14

Sedona 
1FACS7143 **STANDARD**



Sedona is a reddish-brown, terracotta-colored roof tile with a wood-grain texture.

Sterling 
1FACS5759 **STANDARD**



Sterling is a light grey, charcoal-colored roof tile with a wood-grain texture.



*Color Coat products are not available in Southeast & Northeast regions.
The printed colors shown in this brochure may vary from actual available tile colors.

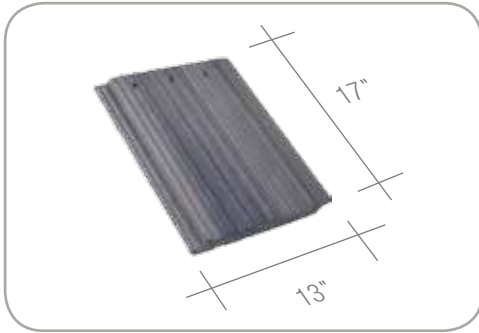

Saxony Shake roof tile perfectly captures the rustic warmth and beauty of country living by recreating the look of hand-hewn shakes. Ideal for French Country, Victorian Craftsman or Cottage architectural styling, these home designs can be enhanced with the diverse color spectrum of the Saxony Shake Collection.

Coverage	Installed Weight/Square	Pieces/Pallet	Squares/Pallet	Weight/Pallet
At 3" minimum headlap, 85 field tiles will cover approx. 100 square feet of roof area.	Approx.: 950 lbs.	288	3.39	Approx.: 3405 lbs.

Shadow Grey



Charcoal Brown Blend



1FBCF1132



CRRC ID# – 0942-0005
Reflectance: 0.18 / Emittance: 0.91 / SRI: 17

Shadow Grey

1FBCF5225

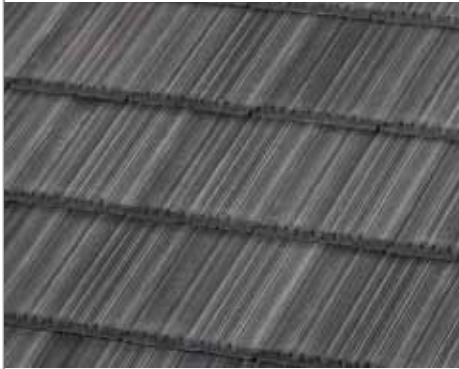

Brown Blend



1FBCF3233



CRRC ID# – 0942-0003
Reflectance: 0.20 / Emittance: 0.91 / SRI: 19

Hickory

1FBCF3726



CRRC ID# – 0942-0065
Reflectance: 0.15 / Emittance: 0.93 / SRI: 14



Brown Blend

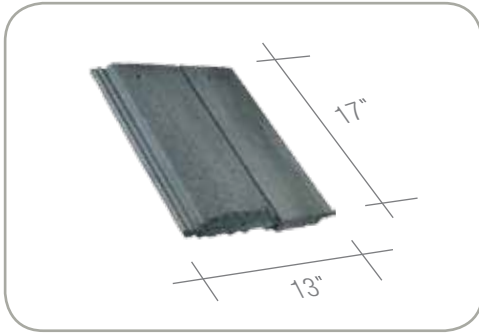

This design features random patterns of coarse and smooth textures and faithfully mimics the appearance of a natural cedar shake roof. Reflecting the beauty and warmth of the country and its hand-hewn split shake roofs, Split Shake is available in a wide variety of rich, rustic colors.

Coverage	Installed Weight/Square	Pieces/Pallet	Squares/Pallet	Weight/Pallet
At 3" minimum headlap, 85 field tiles will cover approx. 100 square feet of roof area.	Approx.: 950 lbs.	288	3.39	Approx.: 3405 lbs.



Weathered Ash 
1FDCV5416



(This block contains a close-up image of Weathered Ash roof shingles, which are a mix of light and dark brown tones.)

Hickory 
1FDCV3726



(This block contains a close-up image of Hickory roof shingles, which are a uniform light brown color.)

CRRC ID# - 0942-0065
Reflectance: 0.15 / Emittance: 0.93 / SRI: 14

Shadow Grey
1FDCV5225



(This block contains a close-up image of Shadow Grey roof shingles, which are a dark charcoal grey color.)

Charcoal Brown Blend
1FDCV1132



(This block contains a close-up image of Charcoal Brown Blend roof shingles, which are a mix of dark brown and charcoal grey tones.)

CRRC ID# - 0942-0005
Reflectance: 0.18 / Emittance: 0.91 / SRI: 17



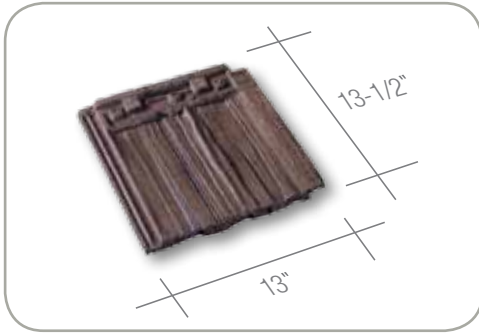

Madera 900 is the most affordable, authentic replication of a hand-split cedar shake roof available. With its realistic wood shake surface, Madera 900 will complement any architectural style.

Coverage	Installed Weight/Square	Pieces/Pallet	Squares/Pallet	Weight/Pallet
At 3-1/2" minimum headlap, 120 field tiles will cover approx. 100 square feet of roof area.	Approx.: 950 lbs.	360	3	Approx.: 3010 lbs.

Mountainwood
1MDCL5001

CRRC ID# - 0942-0110
Reflectance: 0.08 / Emittance: 0.93 / SRI: 5

Autumnwood
1MDCL3002

CRRC ID# - 0942-0070
Reflectance: 0.13 / Emittance: 0.87 / SRI: 8

Vintagewood
1MDCL5011

CRRC ID# - 0942-0089
Reflectance: 0.12 / Emittance: 0.94 / SRI: 11





 In Stock item available in Gilroy upon order.

The printed colors shown in this brochure may vary from actual available tile colors.

Finishing Touches

Boral Roofing provides all of the necessary products for a durable and beautiful roof installation. Our trim tile is the most efficient and attractive way to complete your roof. In addition to rake and ridge pieces, Boral Roofing manufactures hip starters and apex tiles that ease installation. All are protected by our Limited Lifetime, Fully Transferable, Non-Prorated Product Warranty* for tile.

- Precision production techniques provide a consistent look throughout the project
- Colors and textures complement field tile; no need to mix color mortar
- Easier and faster to install than mortar balls; no second steps
- Reduces labor time and expense

Vanguard Roll	Capri Trim				
					
Spanish "S" Nuevo	Capri Trim				
					
Atlantis	Thickbutts	3-Sided Ridge			
					
Barcelona 900	Capri Trim	Capri Hip Starter	Capri Apex 3-Way		
					
Villa 900	Capri Trim	Capri Hip Starter	Capri Apex 3-Way		
					
Saxony® 900 Slate Shake Split Shake	90° Rake	3-Sided Ridge	3-Sided Hip Starter	Apex 3-Way	Apex 4-Way
					
Madera 900	90° Rake	V-Ridge	Tapered Eave Starter		
					

*Please refer to the Boral Limited Lifetime, Fully Transferable, Non-Prorated Product Warranty; details found on our website.

Roof System Components

At Boral we view a roof as not a mere tile covering but a dynamic, performing system that protects, breathes and ages with the structure. By studying roof performance characteristics and failure points, we have created Roof System Components – a collection of components that, when installed properly and used comprehensively, result in a tile roof that lasts longer and increases energy savings.

- Ensures all areas of a roof are protected and utilized for optimum performance
- Improves weatherproofing and “breathability” of a tile roof
- Helps prevent water damage
- Increases airflow and ventilation
- Provides aesthetically pleasing design elements

When used together, selected products form Boral’s Energy Efficient Roof System further reinforcing our belief that we must strive to perfect not only a roof’s aesthetic form, but also its primary function. Only then can we provide our customers with a roofing solution unmatched by any other roofing company.

Vents

It is estimated 75% of homes have deficient attic ventilation, which increases energy costs and diminishes the lifespan of roofing underlayments. These products ensure proper ventilation and help reduce energy costs.

Hip & Ridge

Hips and ridge weather blocking helps prevent wind-driven rain, snow and other debris from entering the peaks and corners of a roof, and increases ventilation.

Valleys

Channeling water properly helps prevent it from collecting on the deck – which can damage the underlayment and cause the roof deck and underlying structure to rot.

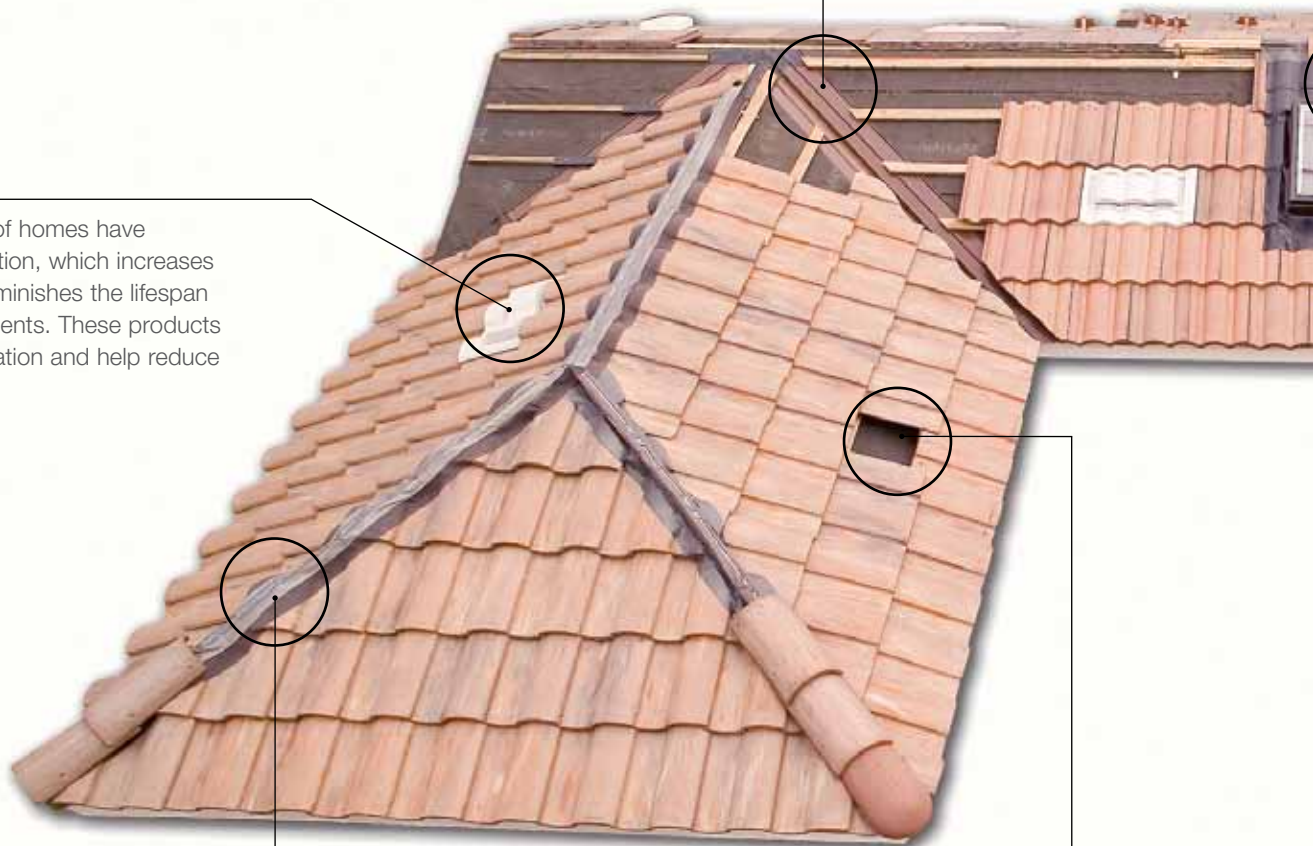

Fasteners and Tools

While standard roofing nails are typically used according to local code requirements, Boral recommends premium fasteners and tools that offer added performance and security.

Flashing

Proper flashings prevent water, snow and debris from entering joints where the walls meet the roof deck. The use of flashing creates the proper barrier in this situation.

Underlayments

While tile is ultimately the first line of defense against the elements, underlayments provide a secondary level of protection directly on top of the roof deck from deterioration, moisture and leaks.

Eaves

Proper eave treatment creates a finished look for the roof and enhances its overall functionality. By elevating the first course of tile to the proper height, it completes the overall aesthetic of the roof, and protection against infestation.

Battens

Our Elevated Battens are a crucial aspect of Boral's Energy Efficient Roof System, and improve the performance of any tile installation. They provide positive anchoring for each tile, raising each tile off the roof deck to provide ventilation and the unrestricted flow of any moisture on the underlayment.

Rake & Gable End

Boral's alternative to rake tiles provide aesthetic options and protection against weather, animal infestation and debris accumulation.



Energy Efficient Roof Systems

Why should you choose Boral's Energy Efficient Roof System? Highly Energy Efficient and Long Lasting.

How does it work?



Tile roofs are highly insulating and prevent much of the sun's heat from penetrating the building. Boral offers tiles in a wide range of profiles in highly reflective colors and certain tiles meet Energy Star and U.S. Green Building Council's LEED (Leadership in Energy and Environmental Design) rating.

In addition to tile's thermal mass, the air space between the tile and the roof deck provides a layer of insulation. Boral Roof Tiles goes a step further by naturally ventilating this air space. Nearly all the heat that penetrates through the tiles is vented through the ridge. This keeps the building cooler, reducing your energy bills every year with no electrical or mechanical parts. Letting your roof system breathe will also make it last longer than traditional tile roof construction.



The most common reason for reroofing is deterioration of the roof system beneath the tiles when tiles or flashings are damaged or installed incorrectly.

Boral roof systems allow moisture that may get under the tiles or flashings to flow down and off the roof deck and quickly dry out, keeping the roof system in good condition to last longer.

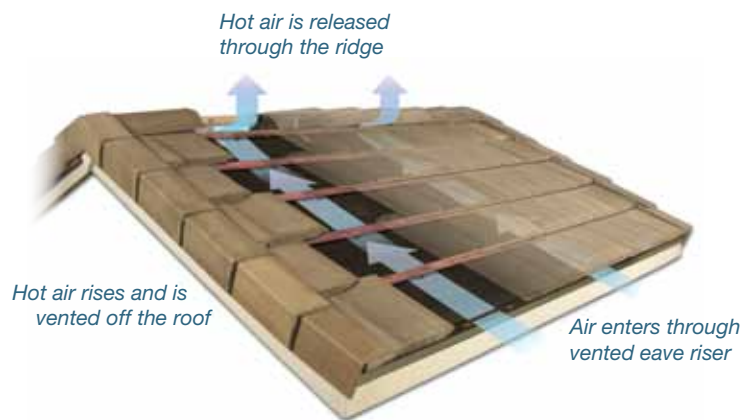

How much could you save?



A family in a typical single family house could save up to 22% per year on heating and cooling costs compared to the standard asphalt shingle roof.* A single family house with a Boral's Energy Efficient Roof System could save an average of \$15 to \$20 per month immediately compared to a standard asphalt shingle roof and as energy rates rise year over year, your savings could increase as well and could amount up to \$20,000 over 30 years.**

Calculate how much you could save by visiting www.BoralNA.com and clicking on the Energy Calculator button.

 Concrete Tile Roof with Energy Efficient Roof System	Asphalt Shingle Roof
 <p>Attic Space 94° †</p> <p>Less Cooling Needs Lower Energy Bill</p>	 <p>Attic Space 139° †</p> <p>High Cooling Needs Higher Energy Bill</p>
<p>Up to Approximately \$20,000 in savings over 30 years**</p> <p>† Temperatures measured in simulated attics using identical heat sources simulating sun's radiation to compare Boral's Energy Efficient Roof System to common asphalt shingle roof system.</p>	

*Steep-slope Assembly Testing of Clay and Concrete Tile with and without Cool Pigmented Colors, Oak Ridge National Laboratory, 2005. Results vary based on profile of tile installed, location, weather and other factors.

**Results based on a 22 square roof in Southern California with no additional energy efficient upgrades during an average annual weather pattern, annual inflation rate of 3%, and annual energy cost increase of 3.5%. Savings may vary based on location, weather and other factors. Savings estimates are based on comparison to similar size asphalt shingle roof.

Eco-Responsible

HIGHLY ENERGY EFFICIENT ROOF SYSTEM COMBINING EARTH FRIENDLY MATERIALS WITH ENERGY STAR RATED ROOF TILES

Energy Star rated roof tiles combined with innovative roof ventilation provide a highly energy efficient roof system. Eco-friendly materials such as concrete or clay, sustainably harvested wood and recycled materials are used to build a system that will last longer. The Elevated Batten System™ combined with StrongSeal® recycled tire rubber underlayment provides superior protection against leaks and contains no asphalt.



Premium

A SUPERIOR SYSTEM WITH BETTER PROTECTION AGAINST THE ELEMENTS AND SIGNIFICANT ENERGY SAVINGS*

Premium quality components and construction methods provide superior durability and energy efficiency.* The Elevated Batten System™ provides natural air insulation and ventilation while eliminating thousands of perforations through the water proofing underlayment. Boral TileSeal® underlayment has a cool white surface and adheres to the deck without nails or staples for better protection against leaks.



Contractor's Choice

AFFORDABLE SYSTEM FOR THE COST-CONSCIOUS

This is an affordable energy saving* roof with better quality and more security than the code minimum standard. This system upgrades a few code required components to create a roof that breathes with the innovative roof ventilation developed by Boral Roofing along with a durable, high performance underlayment at a modest price.



Vented Ridge

- Provides weather protection at hips and ridges
- Exhausts heated air from under the tiles
- Also can ventilate the attic

Underlayment

- High quality protection from the elements as a secondary water proof barrier under tiles
- Underlayments sold by Boral Roofing are backed by a manufacturer's limited warranty

Concrete Tile

- Highly efficient material due to high thermal mass and insulating air space beneath the tiles
- Class A fire rated
- Resistant to rain, snow, hail, fire, noise and high winds - see our Warranty for details*

Vented Eave Riser

- Made to fit the first row of tiles and raise them to proper height
- Provides intake of air for ventilation under the roof tiles
- Profiled styles are decorative and functional

Elevated Batten System™ (EBS)

- Elevates tiles to allow free flow of air and water
- Provides effective thermal barrier and ventilation

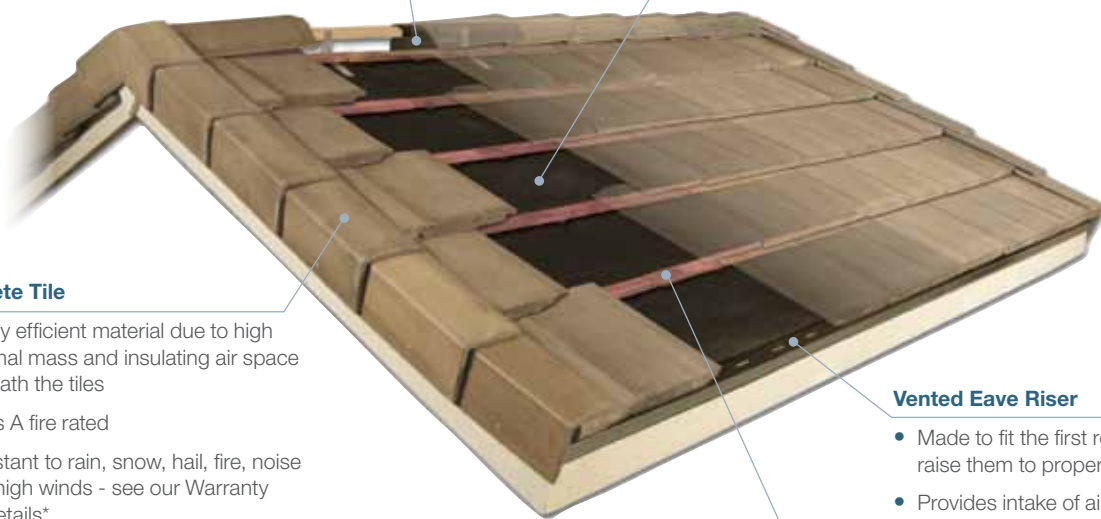

Corporate Office

Boral Roofing

200 Mansell Court East, Suite 310
Roswell, GA 30076

Western Office

Boral Roofing

7575 Irvine Center Drive, Ste. #100
Irvine, CA 92618
949 756 1605

Customer Service

800 669 TILE (8453)

ABOUT BORAL ROOFING

Boral Roofing is a division of Boral USA, the country's largest premium provider of complete roofing and re-roofing solutions for architects as well as commercial and residential builders. Boral Roofing operates 15 clay and concrete tile manufacturing plants throughout the US and Mexico.

ABOUT BORAL USA

Headquartered in Roswell, Georgia, Boral USA through its subsidiaries employs approximately 1,500 individuals at more than 140 operating and distribution sites across the United States. The U.S. operations include the country's largest brick manufacturer and the largest clay and concrete roof tile manufacturer.



Sales Offices

Phoenix, ARIZONA

Corona, CALIFORNIA

Gilroy, CALIFORNIA

Lathrop, CALIFORNIA

Stockton, CALIFORNIA

Rialto, CALIFORNIA

Denver, COLORADO

Pompano Beach, FLORIDA

Lake Wales, FLORIDA

Atlanta, GEORGIA

Kapolei, HAWAII

Kansas City, MISSOURI

Henderson, NEVADA

Katy, TEXAS

Tacoma, WASHINGTON

www.boralna.com



Download a QR Code reader app for your smartphone, then take a photo to visit our website.



The Boral Logo is a trade mark of Boral Limited or its affiliates and may be registered in many jurisdictions worldwide.

