

BORAL ROOFING
Build something great™



Clay Roof Tiles - Lightweight

TILE COLLECTION



Clay Roof Tiles

- Cool Roof and Energy Star Rated
- Strong Warranty*
- Energy Benefits
- Cradle to Cradle - Gold Certified
- 100% Recyclable
- Good for Reroof or New Construction



Natural
& Extensive
Color Offering



Cover: ClayLite Corona de Oro

*Please refer to the Clay Limited Product Warranty; details found on our website at www.boralroof.com

BORAL'S INNOVATIVE PRODUCTS ARE SUSTAINABLE, DURABLE AND BEAUTIFUL



Boral Products are featured in the VISION House® in INNOVENTIONS presented by Green Builder® Media. This green home exhibit is located in INNOVENTIONS at Epcot® at the Walt Disney World® Resort.



Popular Mechanics' Winner 2011 Breakthrough Award
The year's 10 Most Transformative Products

HOME AND HARDWARE
BoralPure® Technology
Smog Eating Concrete Tile

2012 Best New Product Edison Gold Award Winner

MATERIAL SCIENCE
Safety & Sustainability
BoralPure® Technology
Smog Eating Concrete Tile





Why Clay?

Design Style

Boral Roofing has the most extensive choice of profiles and styles of clay roofing tiles in the nation, ranging from traditional mission style barrel tiles to flat tiles that deliver the aesthetics of natural slate and wood shake. The unique design of our lightweight tile products allow for a wide variety of installation options including staggering, boosting, serpentine patterns and much more.

Durability

Clay tile is known for its long-term durability and longevity. Boral's modern manufacturing techniques enhance this durability, giving customers a roofing product that is sure to last.

Sustainability

Boral is the only roof tile manufacturer to receive the prestigious Cradle to Cradle Gold sustainability certification. Our clay tiles

are truly sustainable and do not cause harm to the environment for the life of the product. Our clay roofing products are made with up to 59% recycled raw materials and are 100% recyclable.

Value

Clay tile has proven its durability, longevity and aesthetic appeal over thousands of years. Boral offers a wide range of clay roofing products to fit any budget. From traditional mission tile designs to slate and shake flat profiles, Boral has a clay tile roofing product to meet any project's style and budget.

The Right Roof for the Right Climate

If you live in a climate that experiences full winter weather, consider our products that meet Grade 1 standards per ASTM C1167. If you live in a warmer climate, choose any of our standard weight or lightweight products.

In Stock

This product is kept in stock at the plant and is available for immediate pick up. You can call customer service to confirm product quantities before arriving.

Made To Order

Minimum order quantity is 25 squares. This product will be custom made per your order quantity and will be ready for pick up from our plant in two to three weeks from your order date.



Choose from one of our many cool roof rated tiles that will improve the energy efficiency by reflecting sunlight and heat away from your roof. When these are combined with our Elevated Batten System, they will provide reduced cooling costs and they may even qualify for local rebates. The Cool Roof Rating Council (CRRC) measures the "coolness" of a roof by determining a roof's solar reflectance (SR) and thermal emittance (TE). Both properties are rated on a scale from 0 to 1, where 1 is the most reflective or emissive. The CRRC measures these two properties for roofing products, both for the product's initial values and after three years of weather exposure. Boral Roofing manufactures products that meet CRRC guidelines, allowing homeowners in some regions to receive utility rebates. Boral Roofing's products that are CRRC rated help reduce the heat island effect found in urban areas and in general, increases the overall energy efficiency of the building. For current product ratings please visit our website at www.boralroof.com and click on CRRC logo on the home page.

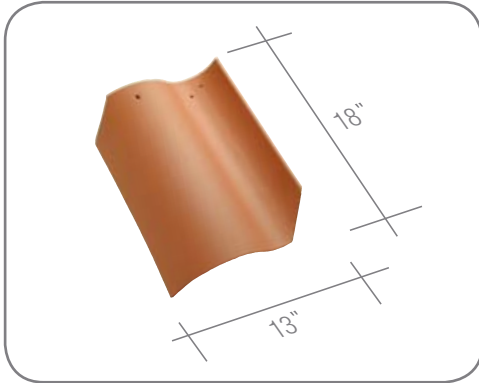

Coverage	Installed Weight / Square
At 3" minimum headlap, 88 field tiles will cover approx. 100 square feet of roof area.	Approx: 590 lbs.

Our ClayLite® product line embodies the innovation that has become synonymous with Boral Roofing. Designed specifically for the reroof market, our unique lightweight ClayLite products weigh less than 600 pounds per square, and do not typically require structural reinforcement.

Made from the same materials and processes as our traditional clay roofing products, ClayLite offers the superior performance, aesthetics, and kiln-fired color palettes with as much as 40% less weight.

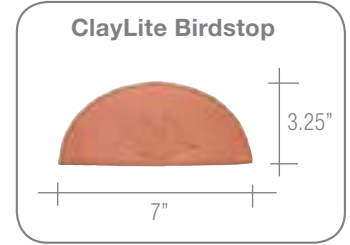



Merlot Blend & Corona De Oro



Viejo Blend & Corona De Oro Blend



ClayLite tile delivers superior durability and consistency without compromising true, kiln-fired looks.



Viejo Blend   59%





CRRR ID# – 0942-0133a
Reflectance: 0.22 / Emittance: 0.83 / SRI: 18

Merlot Blend   59%





CRRR ID# – 0942-0133a
Reflectance: 0.22 / Emittance: 0.83 / SRI: 18

Terracotta   59%



CRRR ID# – 0942-0129
Reflectance: 0.42 / Emittance: 0.85 / SRI: 46

Corona De Oro Blend   49%



CRRR ID# – 0942-0163a
Reflectance: 0.42 / Emittance: 0.83 / SRI: 45

Chaparral Blend   59%



CRRR ID# – 0942-0144a
Reflectance: 0.31 / Emittance: 0.82 / SRI: 30



 In Stock



Select Boral clay products meet or exceed Energy Star requirements.



For current product ratings please visit our website at www.boralroof.com and click on CRRC logo on the home page.



Recycled Content – percentage of pre-industrial content.

The printed colors shown in this brochure may vary from actual available tile colors.



ClayMax®

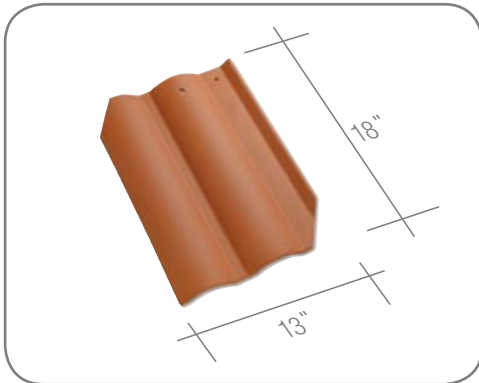

Combining the superior lightweight features and benefits only Boral® can offer, with modern low profile double-barrel tile aesthetics, ClayMax® is ideal for reroofing.



It is also well suited for use on commercial, home owners associations and institutional projects where weight, durability, and cost are key considerations.

ClayMax meets Grade 1 standards per ASTM C1167.

Coverage	Installed Weight / Square
At 3" minimum headlap, 88 field tiles will cover approx. 100 square feet of roof area.	Approx: 580 lbs.





ClayMax also comes in cool roof colors.

Red   59%

2UMDU7025





CRRC ID# – 0942-0129
Reflectance: 0.42 / Emittance: 0.85 / SRI: 46

Newport Blend   59%

2UMDU7040





CRRC ID# – 0942-0160a
Reflectance: 0.19 / Emittance: 0.86 / SRI: 16

Madera Blend   59%

2UMDU3107





El Camino Blend   59%

2UMDU6073



CRRC ID# – 0942-0138a
Reflectance: 0.28 / Emittance: 0.84 / SRI: 27

Black   59% **NEW**

2UMDU1004



 In Stock  Made To Order

 Select Boral clay products meet or exceed Energy Star requirements.

 For current product ratings please visit our website at www.boralroof.com and click on CRRC logo on the home page.

 Recycled Content – percentage of pre-industrial content.

The printed colors shown in this brochure may vary from actual available tile colors.

Monterey™ Shake 600



Modeled after traditional heavy hand-split cedar shakes, this lightweight product was developed to deliver a true rustic, realistic wood appearance, while adding the long lasting benefits of clay.

Weighing less than 600 pounds per square, Monterey Shake was specifically designed for the wood shake replacement market or those looking to replace asphalt roofs with a distinctive product.

Monterey Shake 600 meets Grade 1 standards per ASTM C1167.

Coverage	Installed Weight / Square
120 field tiles will cover approx. 100 square feet of roof area.	Approx.: 598 lbs.



Saddle Mountain Blend



Gold River Blend

2IBOT3300

NEW



CRRC ID# – 0942-0165
Reflectance: 0.18 / Emittance: 0.87 / SRI: 15

Stagecoach Blend

2IBOT3301

NEW



CRRC ID# – 0942-0168
Reflectance: 0.19 / Emittance: 0.88 / SRI: 17

Saddle Mountain Blend

2IBOT5201

NEW



CRRC ID# – 0942-0166
Reflectance: 0.19 / Emittance: 0.86 / SRI: 16

Silver Lake Blend

2IBOT1010

NEW



CRRC ID# – 0942-0167
Reflectance: 0.27 / Emittance: 0.88 / SRI: 27

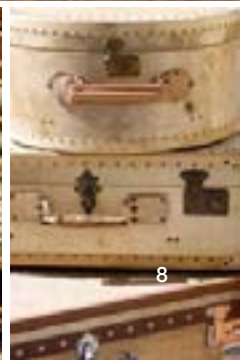

In Stock

 Select Boral clay products meet or exceed Energy Star requirements.

 For current product ratings please visit our website at www.boralroof.com and click on CRRC logo on the home page.

The printed colors shown in this brochure may vary from actual available tile colors.

Faux Mission Installation Technique

The “Faux Mission” installation technique gives architects, builders and homeowners the superior aesthetics of a traditional two-piece clay tile roof at an affordable price.

We carefully designed our ClayLite tile and our traditional 2-Piece Mission tile profiles to fit together, allowing a custom installation that provides the aesthetics of a traditional two-piece tile while capturing the cost saving benefits of a ClayLite. 2-Piece Mission tile is installed at the eave where the details of the roof are most visible. The ClayLite tiles are then installed on the rest of the roof for a much quicker and easier installation than a traditional two-piece tile roof.



Faux Mission - Custom Blend



Faux Mission - Custom Blend



Faux Mission - Custom Blend



GO WITH THE BEST



Boral Products are featured in the VISION House® at INNOVENTIONS presented by Green Builder® Media. This green home exhibit is located in INNOVENTIONS at Epcot® at the Walt Disney World® Resort.

Popular Mechanics' Winner



2011 Breakthrough Award for Home and Hardware
BoralPure® Technology
Smog Eating Concrete Tile

Edison Gold Award Winner



2012 Best New Product in Safety & Sustainability
BoralPure® Technology
Smog Eating Concrete Tile

ABOUT BORAL ROOFING

Boral Roofing is a subsidiary of Boral USA and is the country's largest premium provider of complete roofing and re-roofing solutions for architects as well as commercial and residential builders. Boral Roofing operates 15 clay and concrete tile manufacturing plants throughout the U.S. and Mexico.

ABOUT BORAL USA

Headquartered in Roswell, Georgia, Boral USA through its subsidiaries employs approximately 1,500 individuals at more than 140 operating and distribution sites across the United States. The U.S. operations include the country's largest brick manufacturer and the largest clay and concrete roof tile manufacturer.

Build something great™ with Boral®

Roof Tiles | Roof Accessories | Bricks | Trim | Stone
www.boralna.com



Sales Offices

Phoenix, ARIZONA
Corona, CALIFORNIA
Gilroy, CALIFORNIA
Lathrop, CALIFORNIA
Stockton, CALIFORNIA
Rialto, CALIFORNIA
Denver, COLORADO
Pompano Beach, FLORIDA

Lake Wales, FLORIDA
Atlanta, GEORGIA
Kapolei, HAWAII
Kansas City, MISSOURI
Henderson, NEVADA
Katy, TEXAS
Tacoma, WASHINGTON

Corporate Office

Boral Roofing
200 Mansell Court East, Suite 310
Roswell, GA 30076

Western Office

Boral Roofing
7575 Irvine Center Drive, Ste. #100
Irvine, CA 92618

Customer Service

800 669 TILE (8453)



Download a QR Code reader app for your smartphone, then take a photo to visit our website
www.boralroof.com

©2012 Boral Roofing, LLC BR034 9/12



The Boral Logo is a trade mark of Boral Limited or its affiliates and may be registered in many jurisdictions worldwide.

