



BFC

BUILDERS FENCE COMPANY, INC.
manufacturer • importer • distributor

MANUFACTURING

BFC FENCES AND GATES

- Basic Styles: Regal, Aristocrat & Guardian in Commercial, Industrial and Residential grades
- Single swing, double swing, ground track sliding & full cantilever slide gates
- All welded construction; ready for installation
- All styles modifiable to meet design requirements
- Wide range of finishes available
- Color matching of all colors
- Hardware ranges from full security systems to basic self-closing hinges and locking mechanisms

NATIONWIDE DISTRIBUTION

Builders Fence Company, Inc. is one of the leading manufacturers of ornamental iron fences, gates and security products in the United States. With five branch facilities located in Los Angeles, Fontana, Sacramento, San Diego, and Tacoma, we annually supply tens of thousands of ornamental iron panels for delivery nationwide.

For 50 years, we have been supplying ornamental iron fence for industrial, commercial and residential applications. BFC's highly skilled, experienced craftsmen design and fabricate, in-plant, all fence material and hardware under the most demanding standards of quality control. The specialized production methods used at BFC are further assurances of enduring quality and beauty.

SPECIFIED BY PROFESSIONALS

The quality of workmanship as well as a knowledgeable, efficient sales and service network make Builders Fence Company your obvious choice. Architects nationwide consistently and unhesitatingly specify BFC ornamental iron for government and municipal buildings, industrial plants, commercial centers and residences across the United States and abroad. From panels and gates to security products and hardware, BFC ornamental iron is the top choice of designers and architects.

CUSTOM FABRICATION

Builders Fence Company is one of the few manufacturers specializing in custom fabrication. BFC works regularly with architects, engineers, landscape architects, and designers to tailor ornamental iron fence to the most demanding and unique requirements.

Send us your drawings, plans or specifications.

- BFC product specialists are on hand to review your drawings or specifications and to provide assistance in defining your specific project.
- BFC will gladly modify any of our styles to accommodate a special design feature or particular challenge; or we can fabricate an entirely new look based on your specifications.
- When you need to discuss recommendations for sizes, gauges and hardware, call BFC before specifications are written.
- BFC product specialists can produce drawings in conjunction with your drawings or based upon your concept, design or specification.
- BFC can supply generic drawings of our products as well as AutoCAD drawings for projects being fabricated.



Midwestern University, Arizona

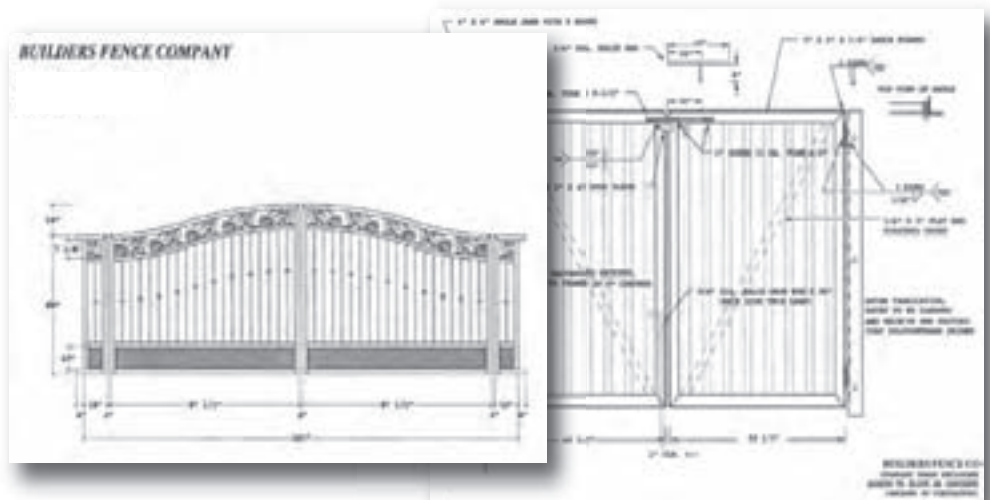

ON THE COVER: *The Irvine Spectrum in Southern California features this double drive, 12 foot tall custom security gate manufactured by BFC.*

BFC GATE SPECIALISTS

COMMERCIAL/RESIDENTIAL

Builders Fence Company specializes in custom gate configurations. Whether it's 13-foot tall solid steel frame gates for U.S. embassies overseas, or a 44-foot long slide gate with restricted view louver infill panels for high wind areas, BFC can do the job.

For ADA compliant installations BFC modifies their pedestrian gates for all types of lever locks, panic bars, and hydraulic closers.

Arched Estate Gates from Builders Fence Co. are accessorized with either standard scrolls and picket castings or highly decorative forgings and ornaments manufactured by popular U.S. foundries.



Custom Designed Arca Gate

BFC SINGLE SWING GATES

DOUBLE SWING GATES

GROUND TRACK ROLLING &

FULL CANTILEVER SLIDE GATES

All gates are available to match the fence style selected or in a variation of the style to accommodate additional functional or decorative features. BFC manufactures a complete line of hardware for all sizes and styles of gates. BFC is also able to furnish most all items for gates per finish hardware section of the project specifications.

AUTOMATED GATES

For over 25 years BFC has been a distributor for many leading gate operator manufacturers. This experience makes BFC expert at supplying gates for automated installations. New UL 325 regulations require automated gates to have reduced space between pickets or steel mesh provided for safety. BFC recommends that the specifier obtains UL 325 regulations from the operator manufacturer specified.



Complete ADA Compliant Security Systems Available

SECURITY GATES AND HARDWARE

With security becoming an integral element in the design of new commercial, industrial and residential buildings, ornamental iron is assuming an increasingly important role. BFC recognizes the need for security barriers that not only provide efficient protection, but are also attractively designed. BFC manufactures panels and gates to accommodate most any hardware condition and distributes a full line of security related hardware.

Extra Heavy Aristocrat bottom track cantilever slide gate





Heavy Regal

BFC HEAVY FENCE STYLES REGAL • ARISTOCRAT • GUARDIAN

STANDARD SIZES:

REGAL & ARISTOCRAT:

Heights: 5', 6', 7', and 8'. Lengths: 94", 118"

GUARDIAN:

Heights: 7', 8', 9', and 10'. Length: 94".

RAILS: 1-1/2" x 1-1/2" 14 ga. steel tube

PICKETS: 3/4" X 3/4" 16 ga. steel tube at 4-3/4" O.C. or 6" O.C.

POSTS: 2" x 2" 14 or 11 ga. steel tube with pressed steel cap.
Space posts at 8' O.C. or 10' O.C.

SWING GATES: Framework as required for size, but not less than that of panels.
Pickets to match panels. Hardware as required. Trussing and heavier posts may be necessary.

SLIDE GATES: 2" x 2" x 11 ga. steel tube top rail and verticals. Bottom rail shall be 2" x 4" x 11 ga. steel tube with wheel housings. Ground track to be angle iron (sized per requirements) with #4 rebar hooks welded at 24" O.C. Wheels shall be 6" diameter V-Groove type with grease fitting and needle bearings. Upper guides to be BFC Type I roller assemblies with 2" diameter hard rubber rollers, 1/2" axle, and bronze bushings. Safety posts to be minimum 4" sq. 11 ga. steel tube.

RECOMMENDED FINISH: Galva-Guard I

See page 7 of this brochure for a complete listing of finish options.
Custom Color Matching Available

XTRA-HEAVY REGAL: 2" rail (14 ga.) - 1" pickets (16 ga.) - 5" O.C. or 6" O.C.

XTRA-HEAVY ARISTOCRAT: 2" rail (14 ga.) - 1" pickets (16 ga.) - 5" O.C. or 6" O.C.

XTRA-HEAVY GUARDIAN: 2" rail (14 ga.) - 1" pickets (16 ga.) - 5" O.C. or 6" O.C.

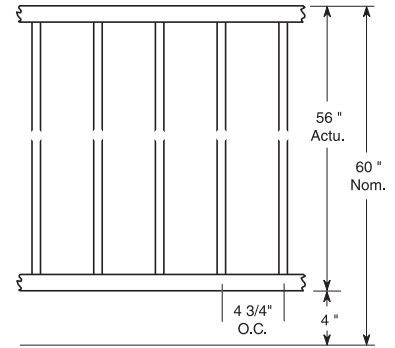

Typical Regal

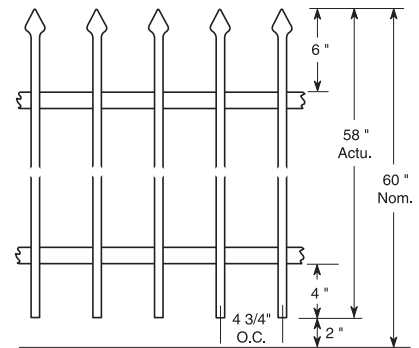

Typical Aristocrat

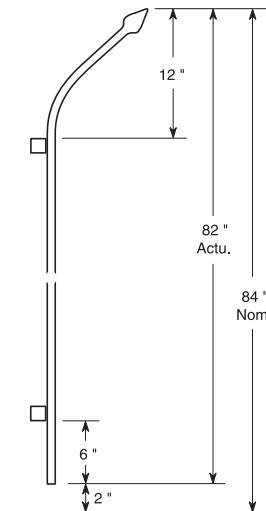

Typical Guardian

INDUSTRIAL/COMMERCIAL



Heavy Aristocrat On Wall

WELDED STEEL CONSTRUCTION PROVIDES OPTIMUM STRENGTH

BFC Heavy and Extra-Heavy Grade Iron Fencing continues to be the first choice of specifiers of true security fencing. BFC's all-welded construction ensures durability and rigidity that "erector-set" type fences cannot produce. BFC gladly modifies any of these styles to meet clients' custom requirements.



Heavy Guardian

INSTALLATION: All fence panels and gates are delivered prepared for welded installation. BFC offers wall mount and post mounting brackets if required.

Fence Design Variations

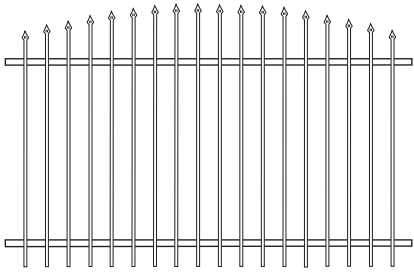

Style Variation 005

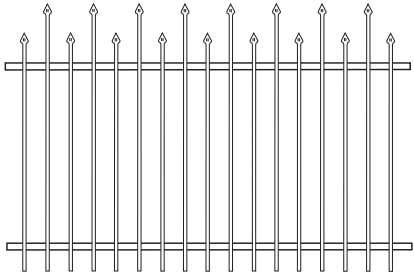

Style Variation 001

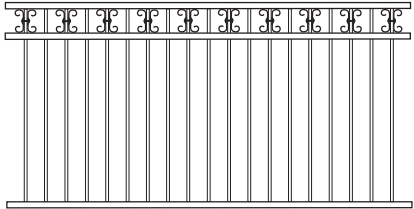

Style Variation 009

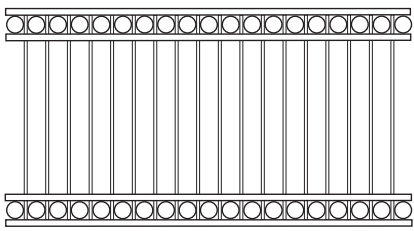

Style Variation 012

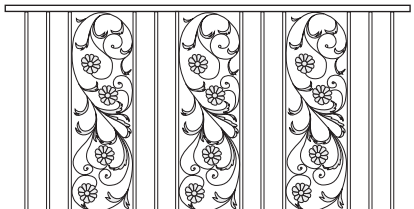

Style Variation 010

Many other style variations are available. For more options and a complete Architect Handbook, please fax a request to (818) 768-9454.

BFC RESIDENTIAL

BFC Residential Iron Fencing adds both beauty and security to any home.

STANDARD HEIGHTS TO GROUND LEVEL:

3', 4', 5', 6'

STANDARD PANEL LENGTHS:

94", 120" & 143 1/2"

STANDARD TUBE SIZES:

PICKETS (SQUARE) 5/8" X 5/8" 18 ga.

RAILS (SQUARE) 1" X 1" 16 ga.

RECOMMENDED FINISH: Galva-Guard I

Note: See page 7 for optional finishes.

GATE AVAILABILITY:

Single swing, double swing, ground track sliding & full cantilever slide gates.

Custom lengths can be manufactured at either nominal or no additional costs.

POSTS:

Posts are supplied according to weight and size of fence material. They are available for dirt-set, concrete-set or flange mounting.

INSTALLATION:

All fence panels and gates are delivered prepared for welded installation. BFC offers wall mount and post mounting brackets if required.

OPTIONS:

BFC's Residential Iron Fencing offers endless choices of twisted pickets, scroll work, cast iron finials, rings, flame-cut letters and arching rails providing a unique design for the home.



Arched Modern With Castings



Typical Modern Panels

RESIDENTIAL STYLES

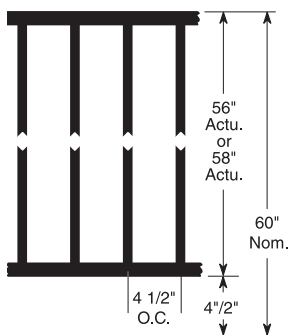

REGAL

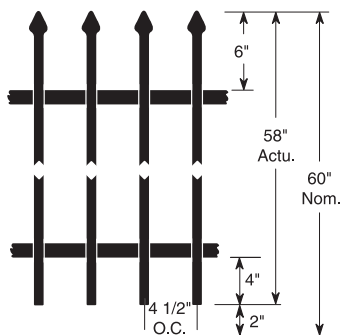

ARISTOCRAT

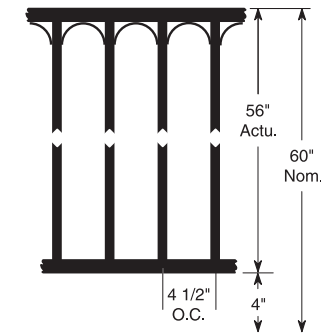

EMPIRE

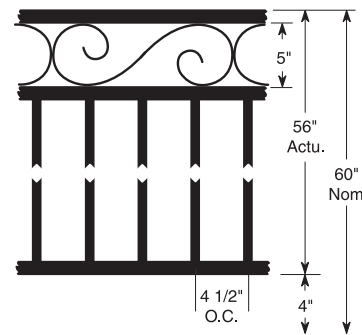

NAPOLEON

RESIDENTIAL

FINISH OPTIONS

GALVA-GUARD I - Recommended Paint Finish

Pre-Galvanized Tubing and Polyurethane Painted

Materials are fabricated using galvanized tubing and finished with one spray coat of high solids primer and one spray coat of high solids gloss black polyurethane paint.

Extended warranty is available.

GALVA-GUARD II - For Even More Protection

Hot-Dipped Galvanized and Polyurethane Painted

After fabrication, materials are hot-dipped galvanized per ASTM-A 123 and finished with one spray coat of high solids polyurethane primer and one spray coat of gloss black polyurethane paint.

Extended warranty is available.

Polyurethane paint is a high solids aliphatic two component polyurethane coating system that offers long lasting gloss and color retention.

BFC polyurethane coating can match any color specified.

BFC STANDARD POLYURETHANE COLORS - CUSTOM COLOR MATCHING AVAILABLE



BFC STANDARD POLYESTER POWDER COAT COLORS - CUSTOM COLOR MATCHING AVAILABLE

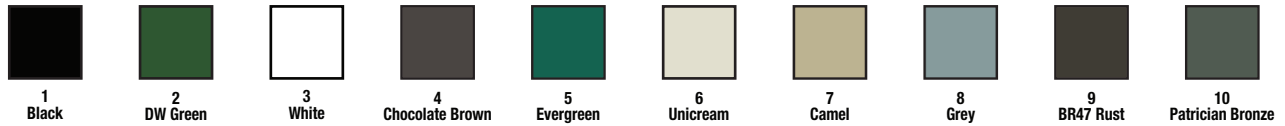

GALVA-GUARD III - Recommended Powder Finish

Pre-Galvanized Tubing and Polyester Powder Coated

Materials are fabricated using galvanized tubing and finished with one powder coat of zinc-rich epoxy primer and one coat of polyester powder coat black.

Extended warranty is available.

Polyester powder coating, known for its hard durable finish, is available in a wide selection of colors.

GALVA-GUARD I, II and III provide long lasting beauty and superior corrosion protection.

In addition to our recommended finishes above, BFC also offers the following more economical finish for use in dry, non-corrosive environments.

BFC POLY PRO + Polyurethane Painted

After fabrication, materials are power washed in an iron phosphate solution and receive one spray coat of high solids polyurethane primer and one spray coat of high solids gloss black polyurethane paint.





*Whether with
our own fleet
of trucks
or by common
carrier,
BFC delivers
nationwide.*

SPECIFICATIONS

PART 1 - General

1.01 WORK INCLUDED

This specification covers ornamental iron fence materials including ornamental iron gates, posts and hardware.

1.02 RELATED WORK

Section ___ - Earthwork

Section ___ - Concrete

Section ___ - Painting

1.03 SYSTEM DESCRIPTION

The manufacturer shall supply a complete ornamental fencing system including all components defined herein (fence panels, posts, gates and hardware).

1.04 QUALITY ASSURANCE

The contractor must be familiar with the construction methods and materials involved in ornamental iron fencing.

1.05 REFERENCES

ASTM A 36 - Structural Steel, Bars, Flats and Shapes

ASTM A 123 - Zinc (Hot-dipped Galvanized) Coatings

ASTM A 500 - Steel Structural Tubing in Rounds and Shapes

ASTM A 513 - Electric-Resistance-Welded Carbon and Alloy Steel Mechanical Tubing

1.06 SUBMITTALS

Submit the manufacturer's shop drawings and literature prior to installation. Approved shop drawings shall become the basis for acceptance of the work.

1.07 DELIVERY, STORAGE, AND HANDLING

Deliver to the job site materials in good condition and properly protected against damage to factory-finished surfaces.

Store materials in a clean, dry location and in such a way as to avoid damage, especially from dust, chemicals and moisture in the air by covering with protective material. Handle materials carefully on the job site to protect factory finishes.

1.08 WARRANTY

Builders Fence Co., Inc. hereby certifies that it manufactures the ornamental iron fencing and gates in accordance with specifications and/or shop drawings supplied by BFC. Builders Fence

Co., Inc. assumes the responsibility of providing products meeting BFC's prescribed specifications. Local environmental factors vary widely, therefore BFC does not guarantee that its product will perform in any defined manner in any specific environment. Damage to coating due to shipping and installation is to be expected and must be adequately touched up or repainted immediately after occurrence by installer to meet original specification standards.

PART 2 - Products

2.01 ACCEPTABLE MANUFACTURERS

The ornamental fencing system shall be manufactured by :

Builders Fence Company, Inc.

P.O. Box 125

Sun Valley, CA 91353-0125

1•800•767•0367

2.02 MATERIALS

A. Pickets, rails, and posts shall be manufactured from tubing meeting the requirements of ASTM A 513 or A 500 Grade B.

B. Solid steel bars, flat plates and shapes shall be manufactured from steel conforming to the requirements of ASTM A 36.

C. Pickets for gates shall be of the same size and style as those in the fence panels. Frames for gates shall be of sufficient size and thickness to provide adequate support without sag. Adjustable trussing may be required. Gate hardware shall be supplied by the manufacturer and shall be of sufficient size and capacity to support the gate specified.

2.03 FABRICATION - General

A. Steel used in the manufacturing of panels, gates and posts shall conform to the ASTM standards specified and shall be new prime material.

B. Panels, gates and flanged posts shall be of welded construction. No wire rods, screws or rivets shall be accepted to attach pickets to rails. Layout and welding shall be done by experienced craftsmen. Welds shall be made by the gas metal arc method and welds shall be neat, clean and of the sizes indicated on the drawings. All flush welds shall be ground smooth.

C. After fabrication panels, gates and posts shall be power washed in a phosphoric acid solution, rinsed and dried.

Finish shall be chosen from one of the following:

- BFC GALVA-GUARD I
- BFC GALVA-GUARD II
- BFC GALVA-GUARD III
- BFC POLY-PRO+

PART 3 - Execution

3.01 PREPARATION

A. The contractor shall layout the new fence in accordance with the fence construction plans, shop drawings, and all applicable requirements and codes.

B. The contractor shall verify any grade changes or surface irregularities.

C. Discrepancies between the approved shop drawings and field conditions must be approved by the architect or engineer prior to proceeding with the installation.

3.02 INSTALLATION

A. Fence posts shall be set plumb and level at spaces shown on the drawings. Footings shall be of the sizes indicated. Post caps shall be as indicated on the drawings.

B. Fence panels shall be welded or bolted to the posts. Field welding of rail to the post shall be a complete 360 degree (all four sides) and shall be the size indicated on the drawings. Welds shall be cleaned and coated with a primer the same day the welding is performed. Bolted connections shall use bolts and tabs of the size indicated on the drawings. After tightening bolt, threads shall be peened.

C. Gates shall be installed plumb and level and shall be the sizes and style indicated on the drawings. The contractor shall install any gate stops that may be required. Any padlock provisions or strikes shall be field attached to assure alignment. The contractor shall lubricate the hinges, rollers and other gate hardware after installation.

D. All field welds and any abrasions to factory coatings shall be thoroughly cleaned, re-primed and touched up by the contractor with paint of the same quality, color and gloss of that used by the manufacturer.

3.03 CLEANING

A. The contractor shall clean job site of excess materials.

B. Post hole excavations shall be scattered uniformly away from the posts or removed as directed.

C. Concrete splatter shall be cleaned from exposed posts.

*For a complete Architect Handbook,
please FAX a request to (818) 768-9454*

web: www.buildersfence.com

email: bfc@buildersfence.com

Member:

American Fence Association (AFA)

National Ornamental & Miscellaneous

Metals Association (NOMMA)

Chain Link Fence Manufacturers Institute (CLFMI)

BUILDERS FENCE COMPANY, INC.

PO BOX 125 • SUN VALLEY, CA 91353-0125

1-800-767-0367 • FAX 818-768-9454



© 2009 Builders Fence Company, Inc.