



511 SOUTH 7TH STREET  
DELANO MN 55328  
**Phone: 763.972.2981**  
Fax: 763.972.2911

[www.industriallouvers.com](http://www.industriallouvers.com)  
[ilinfo@industriallouvers.com](mailto:ilinfo@industriallouvers.com)

# MODEL 436-H

## STANDARD CONSTRUCTION

Frame and blades to be 4" deep .081 extruded aluminum 6063 alloy.

1/2" mesh .063 flattened expanded aluminum bird screens in a removable extruded aluminum frame.

Finish to be mill.

## INSTALLATION

Model 436-H should be installed in accordance with manufacturers recommended attachment method and in accordance with state and federal building codes.

## WARRANTY

All materials and workmanship are warranted for a period of 1 year from date of completion.

## MAINTENANCE

None required.

## FEATURES

- All sizes are custom fabricated to meet project requirements.
- Channel frame.
- Sight proof blades.
- Clip angles for installation.

## OPTIONAL ACCESSORIES

Many optional accessories to the basic design are available at an additional cost. They include:

- Extended sill flashing
- Flanged frames of various sizes
- Hinged access panels
- Subframes
- Continuous perimeter angles
- Visible or invisible mullions for multiple section requirements.
- Anodized, Baked Enamel or Kynar finish

Please contact the factory for other special requirements.

## SUGGESTED SPECIFICATIONS

Furnish and install where indicated on the drawings ILI sight proof Model 436-H louvers as manufactured by Industrial Louvers, Inc., Delano, MN. Frames and blade thickness to be .081" extruded aluminum 6063 alloy. Sill and jamb frames shall be continuously welded and caulked to help prevent water penetration to interior wall construction. Blades are attached by means of mechanically fastened construction.

The louvers shall have a minimum of 6.12 sq. ft. (42%) free area on a 48 inch x 48 inch louver.

CATALOG NO. 436-H

Rev: JULY 2010

# MODEL 436-H

## Free Area in Square Feet And Square Meters

Free Area for openings up to 72" X 120".

For free area data for larger openings, contact factory.

### FREE AREA IN SQUARE FEET AND SQUARE METERS

3048. mm	0.365	0.803	1.241	1.678	2.116	2.554
<b>120"</b>	<b>3.930</b>	<b>8.642</b>	<b>13.354</b>	<b>18.066</b>	<b>22.778</b>	<b>27.49</b>
2743.2 mm	0.327	0.719	1.110	1.502	1.894	2.286
<b>108"</b>	<b>3.518</b>	<b>7.736</b>	<b>11.954</b>	<b>16.172</b>	<b>20.390</b>	<b>24.608</b>
2438.4 mm	0.288	0.634	0.980	1.326	1.672	2.018
<b>96"</b>	<b>3.106</b>	<b>6.830</b>	<b>10.554</b>	<b>14.278</b>	<b>18.002</b>	<b>21.726</b>
2133.6 mm	0.250	0.550	0.850	1.150	1.451	1.751
<b>84"</b>	<b>2.693</b>	<b>5.923</b>	<b>9.153</b>	<b>12.383</b>	<b>15.613</b>	<b>18.843</b>
1828.8 mm	0.212	0.466	0.720	0.974	1.229	1.483
<b>72"</b>	<b>2.281</b>	<b>5.017</b>	<b>7.753</b>	<b>10.489</b>	<b>13.225</b>	<b>15.961</b>
1524. mm	0.173	0.382	0.590	0.798	1.007	1.215
<b>60"</b>	<b>1.869</b>	<b>4.111</b>	<b>6.353</b>	<b>8.595</b>	<b>10.837</b>	<b>13.079</b>
1219.2 mm	0.135	0.297	0.460	0.622	0.785	0.947
<b>48"</b>	<b>1.457</b>	<b>3.205</b>	<b>4.953</b>	<b>6.701</b>	<b>8.449</b>	<b>10.197</b>
914.4 mm	0.097	0.213	0.330	0.446	0.563	0.680
<b>36"</b>	<b>1.044</b>	<b>2.298</b>	<b>3.552</b>	<b>4.806</b>	<b>6.060</b>	<b>7.314</b>
609.6 mm	0.058	0.129	0.200	0.270	0.341	0.412
<b>24"</b>	<b>0.632</b>	<b>1.392</b>	<b>2.152</b>	<b>2.912</b>	<b>3.672</b>	<b>4.432</b>
304.8 mm	0.020	0.045	0.070	0.094	0.119	0.144
<b>12"</b>	<b>0.220</b>	<b>0.486</b>	<b>0.752</b>	<b>1.018</b>	<b>1.284</b>	<b>1.55</b>
<b>H/W</b>	304.8 mm	609.6 mm	914.4 mm	1219.2 mm	1524. mm	1828.8 mm
	<b>12"</b>	<b>24"</b>	<b>36"</b>	<b>48"</b>	<b>60"</b>	<b>72"</b>



CATALOG NO. 436-H

Rev: JULY 2010

# MODEL 436-H

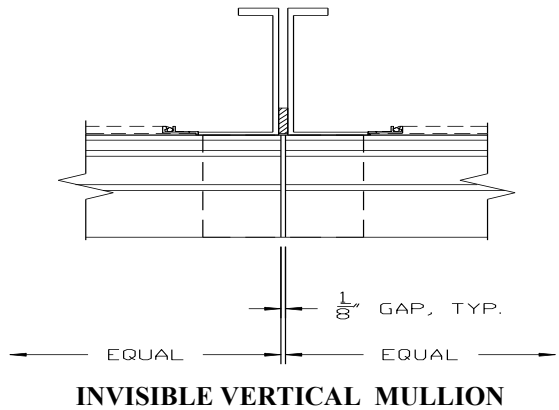
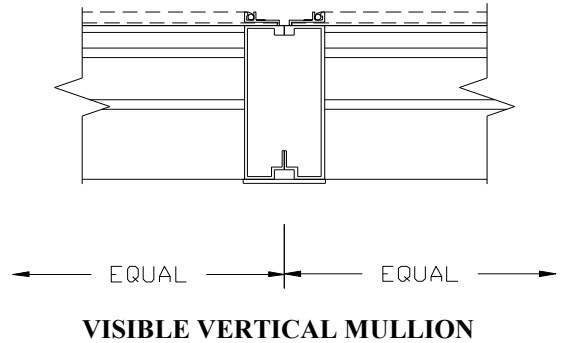
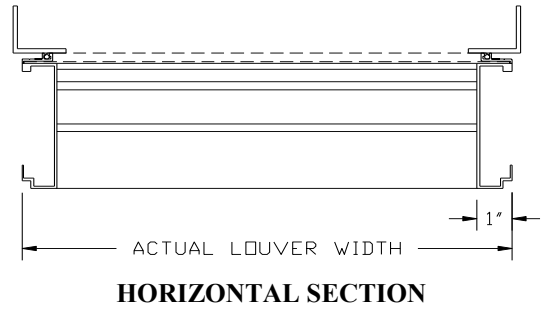
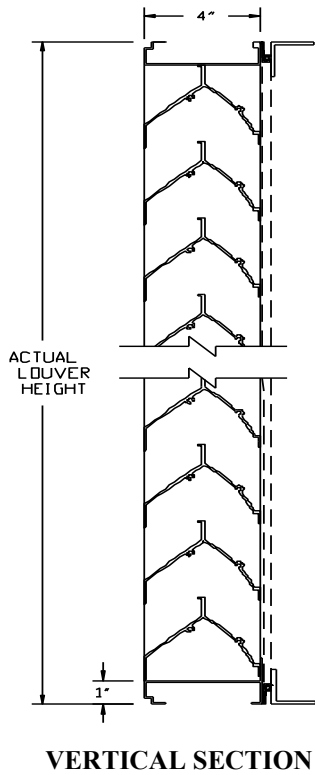

**ACCESSORIES:**

- SILL FLASHING - DEPTH \_\_\_\_\_
- SCREEN \_\_\_\_\_
- FINISH \_\_\_\_\_
- COLOR \_\_\_\_\_
- OTHER \_\_\_\_\_

ITEM NO.	QTY	SIZE		M.O.	MULLION TYPE	NO. OF SECTIONS	REMARKS
		Actual	Width				
		<input type="checkbox"/>		<input type="checkbox"/>			

PROJECT _____	REPRESENTATIVE _____
LOCATION _____	ILI JOB NO. _____ REP NO. _____
ARCH/ENGR. _____	Industrial Louvers, Inc. Phone: 763-972-2981
CONTRACTOR _____	511 South 7th Street Fax: 763-972-2911
DATE _____	Delano, MN 55328
	CATALOG NO. 436-H Rev: JULY 2010